



GOVERNMENT OF JHARKHAND

**JHARKHAND INDUSTRIAL AREA
DEVELOPMENT AUTHORITY**

STANDARD BIDDING DOCUMENT

COMPLETE BIDDING DOCUMENT

STANDARD BIDDING DOCUMENT JHARKHAND

PROCUREMENT OF CIVIL WORKS

Name of the Work :- Construction of Basic Infrastructures Such as Roads drain Utility duct Street Light etc of international Level for Hazaribagh industrial Area JIADA.

COMPLETE BIDDING DOCUMENT

**INVITATION FOR BID
(IFB)**

e-Procurement Cell

JHARKHAND INDUSTRIAL AREA DEVELOPMENT AUTHORITY

3rd floor New JIADA Building, Industrial area Namkum, Ranchi 834010

3rd floor JIADA Industrial area Namkum Ranchi 834010

e-Procurement Notice

e-Tender Reference No.- JIADA/SBD/03/Hzaribagh/2024-25

Date:20.09.2024

1	Name of Work	Construction of Basic Infrastructures (Such as Roads, drain, Utility duct, Street Light etc) of international Level for Hazaribagh industrial Area JIADA.
2	Estimated Cost (Rs.)	8,11,94,840.00 (Rupees Eight crore Eleven lakh Ninety Four thousand Eight Hundred Forty only)
3	Time of Completion	12 (twelve) Months
4	Date of Publication of Tender on Website	01.10.2024
5	Last Date/Time of Submission of Bids	16.10.2024 at 5:00 P.M.
6	Date/Time of opening of Bid	18.10.2024 at 3:30 P.M.
7	Name & Address of Office Inviting Tender	OFFICE OF THE MANAGING DIRECTOR JIADA, 3rd FLOOR NEW JIADA BUILDING, INDUSTRIAL AREA,NAMKUM, RANCHI-834010
8	Advt. Letter No./Dated	669/20.09.2024
9	Contact No. of Procurement officer	9431386208
10	Helpline Number of e-procurement Cell	9431386208

Further details can be seen on Website <http://jharkhandtenders.gov.in>

Sd/-

Secretary,
JIADA,
3rd floor, New JIADA Building,
Industrial area, Namkum,
Ranchi-834010

GOVERNMENT OF JHARKHAND
JHARKHAND INDUSTRIAL AREA DEVELOPMENT AUTHORITY
 3rd floor, New JIADA Building, Industrial area, Namkum, Ranchi-834010

INVITATION FOR BIDS (IFB)
NATIONAL COMPETITIVE BIDDING

e-Tender Reference No.- JIADA/SBD/03/hazaribagh/2024-25

Date:20.09.2024

The Secretary JIADA, on behalf of the Managing Director, JIADA, invites item rate bids for the work mentioned in table below through e-Procurement from eligible and approved Contractors, registered in appropriate class with Road Construction Department Government of Jharkhand. Those contractors who are not registered with Road Construction Department Government of Jharkhand are also permitted to take part in tender process. In such case the Contractor should be registered in any State Government/ Central Government/ Public Sector Unit/undertaking in appropriate class However such Contractors in the event of award of work will perform have to get registered with Road Construction Department Government of Jharkhand within a period of (3) three Months from date of Award of Contract. The bid shall be submitted online in the Website <http://jharkhandtenders.gov.in>. The bidder(s) should have necessary portal enrolment with their own Digital Signature Certificate:

Sl. No.	Name of the work	Approximate value of work (Rs.)	Bid Security* (Rs.)	Cost of Document (Rs)	Period of Completion
1	2	3	4	5	6
1	Construction of Basic Infrastructures (Such as Roads, drain, Utility duct, Street Light etc) of international Level For Hazaribagh industrial Area JIADA.	8,11,94,840.00	8,12,000.00	10000.00	12 months

2. Period of availability of tenders online/date & time of bidding on-line / last date of seeking clarification/date of opening of tender papers are as given below –

Sl. No.	Procurement Officer	Place of Opening	Availability of Tender on-line for bidding		Date & Time of Opening of Technical Bid
			From	To	
1	2	3	4	5	6
	Secretary , JIADA, Ranchi	JIADA, 3rd floor, New JIADA Building, Industrial area, Namkum, Ranchi-834010	01.10.2024	16.10.2024 at 5:00 P.M.	18.10.2024 at 3:30 P.M.

3. Tenderer (s) shall upload Scanned copy in PDF format/Digitally Signed copy of his/her Valid Electrical Licenses Credit Facility, PAN, Five Years Audited Turnover, Character Certificate, Work Experience, UCAN, Partnership Deed or Article of Association / Memorandum , Undertakings, Affidavits, E.P.F, GST etc.
4. Bids shall be submitted online on the website <http://jharkhandtenders.gov.in>.
5. Uploaded documents of successful bidder will be verified with the original before signing the agreement. The successful bidder has to provide the originals to the concerned authority on receipt of such a letter, which will be sent through registered post or speed post or delivered by hand.
6. Bidders in order to participate in the bidding process have to get 'Digital Signature Certificate (DSC)' as per Information Technology Act-2000 to participate in online bidding. This certificate will be required for digitally signing the bid. Bidders can get the above mentioned digital signature certificate from any approved vendors (CCA). Bidders, who already possess valid Digital Certificates, need not procure new Digital Certificate.
8. Bidders have to submit their bids online in electronic format with Digital Signature. Bids without Digital Signature will not be accepted. No proposal will be accepted in Physical Form.
9. *A pre-bid meeting will be held on at 1.00 P.M. hrs. in the office of JIADA, 3rd floor, New JIADA Building, Industrial area, Namkum, Ranchi-834010 matter that may be raised at that stage as to Bidders of the to clarify the issues and to answer questions on any matter that may be raised at that stage as stated in clause 9.2 of the Instructions to bidders of the bidding document. *(Deleted)
10. The price escalation/deduction on account of change in price of bitumen will be admissible as per RCD, Jharkhand, Ranchi's Circular No- 5757 (S) Dt. 02.09.2008.* Deleted.

The Date & Time as displayed on portal shall be valid for all action(s) of requesting bid submission & bid opening etc.

1. Bid shall be submitted online through <http://jharkhandtenders.gov.in>
2. Cost of bidding document (for a non refundable fee) & Bid security as indicated shall be payable online through <http://jharkhandtenders.gov.in> in adherence to the order issued vide memo no. 120, dated : 03.10.2023 of Information Technology & e- Government Department, Govt. of Jharkhand.
3. Other details can be seen in the bidding documents.
4. GST @18% and Labour Cess @ 1% is included in the BOQ Amount.

Sd/-
Secretary,
JIADA,
3rd floor, New JIADA Building,
Industrial area, Namkum,
Ranchi-834010

*Bid Security 1% of Bid Amount.

** To be deleted for Project costing less than Rs. 20 crores.

Note: Bid Security will be a fixed sum rounded off to the nearest one thousand Rupees.

SECTION 1
INSTRUCTIONS TO BIDDERS
(ITB)

Section 1: Instructions to Bidders

Table of Clauses

	Page No.		Page No.
A. General		D. Submission of Bids	
1. Scope of Bid	9	19. Sealing and Marking of Bids	20
2. Source of Funds	9	20. Deadline for Submission of Bids	21
3. Eligible Bidders	9	21. Late Bids	21
4. Qualification of the Bidder	9	22. Modification and Withdrawal of Bids	21
5. One Bid per Bidder	15		
6. Cost of Bidding	15		
7. Site Visit	15		
B. Bidding Documents		E. Bid Opening and Evaluation	
8. Content of Bidding Documents	15	23. Bid Opening	22
9. Clarification of Bidding Documents	16	24. Process to be Confidential	23
10. Amendment of Bidding Documents	17	25. Clarification of Financial Bids	23
		26. Examination of Bids and Determination of Responsiveness	23
		27. Correction of Errors	24
		28. Deleted	24
		29. Evaluation and Comparison of Financial Bids	24
		30. Deleted	24
C. Preparation of Bids		F. Award of Contract	
11. Language of Bid	17	31. Award Criteria	25
12. Documents Comprising the Bid	17	32. Employer's right to Accept any Bid and to reject any or	25
13. Bid Prices all Bids	17	33. Notification of Award and Signing of Agreement	25
14. Currencies of Bid and Payment	18		
15. Bid Validity	18	34. Performance Security	26
16. Bid Security	18	35. Advance Payment and Security	26
17. Alternative Proposals by Bidders	19	36. Deleted	26
18. Format and Signing of Bid	19	37. Corrupt or Fraudulent Practices	26

A. GENERAL

1. Scope of Bid

- 1.1 The Employer (named in appendix to ITB) invites bids for the construction of works (as defined in these documents and referred to as “the works”) detailed in the table given in IFB. The bidders may submit bids for any or all of the works detailed in the table given in IFB.
- 1.2 The successful bidder will be expected to complete the works by the intended completion date specified in the Contract data.
- 1.3 Throughout these bidding documents, the terms ‘bid’ and ‘tender’ and their derivatives (bidder/ tenderer, bid/tender, bidding/tendering, etc.) are synonymous.

2. Source of Funds

The expenditure on this project will be met from the budget of Govt. of Jharkhand, and JIADA

3. Eligible Bidders

- 3.1. This invitation for Bids is open to all bidders.
- 3.2. All bidders shall provide in Section 2, Forms of Bid and Qualification Information, a statement that the Bidder is neither associated, nor has been associated, directly or indirectly, with the Consultant or any other entity that has prepared the design, specifications and other documents for the Project or being proposed as Project Manager for the Contract. A firm that has been engaged by the Employer to provide consulting services for the preparation or supervision of the works, and any of its affiliates, shall not be eligible to bid.

4. Qualification of the Bidder

- 4.1. All bidders shall provide in Section 2, Forms of Bid and Qualification Information, a preliminary description of the proposed work method and schedule, including drawings and charts, as necessary. The proposed methodology should include programme of construction backed with equipment planning and deployment duly supported with broad calculations and quality assurance procedures proposed to be adopted justifying their capability of execution and completion of work as per technical specifications, within stipulated period of completion.
- 4.2 * In the event that Pre-qualification of potential bidders has been undertaken, only bids from pre-qualified bidders will be considered for award of Contract. These qualified

bidders should submit with their bids any information updating their original prequalification applications or alternatively, confirm in their bids that the originally submitted prequalification information remains essentially correct as of date of bid submission. The update or confirmation should be provided in section 2. A copy of the original prequalification application and the letter of prequalification should also be furnished. With the updated information, the bidder must continue to be qualified in accordance with the criteria laid down in the prequalification document. All bidders shall also furnish the following information in Section 2.

** Delete , if Post-qualification is to be carried out.*

- (i) Evidence of access to or availability of credit facilities (minimum 10% of Estimated Cost) certified by the bankers.
- (ii) Undertaking that bidder would be able to invest a minimum of cost upto 25% of the contract value of work, during implementation of contract.
- (iii) Proposals, if any, for sub contracting of elements of work, costing more than 10% of the bid amount.
- (iv) ** Power of attorney.*

4.3* If the Employer has not undertaken prequalification of potential bidders, all bidders shall include the following information and documents with their bids in Section 2:

- (a) copies of original documents defining the constitution or legal status, place of registration, and principal place of business; written power of attorney of the signatory of the Bid to commit the Bidder;
- (b) total monetary value of construction work performed for each of the **last five years**.
- (c) experience in works of a similar nature and size for each of the last five years, and details of works underway or contractually committed; and clients who may be contacted for further information on these contracts;
- (d) major items of construction equipment proposed to carry out the Contract;
- (e) qualifications and experience of key site management and technical personal proposed for Contract;
- (f) reports on the financial standing of the Bidder, such as profit and loss statements and auditor's reports for the past five years;
- (g) evidence of access to line (s) of credit and availability of other financial resources facilities (10% of contract value), certified by the Bankers(not more than 3 months old)
- (h) undertaking that the bidder will be able to invest a minimum cash upto 25% of contract value of work, during implementation of work.
- (i) authority to seek references from the Bidders's bankers;
- (j) information regarding any litigation, current or during the last five years, in which the Bidder is involved, the parties concerned, and disputed amount;

** Delete , if pre-qualification is to be carried out.*

- (k) proposals for subcontracting components of the works amounting to more than 10 percent of the Bid Price (for each, the qualifications and experience of the identified sub-contractor in the relevant field should be annexed); **and for all specialized nature of work & new engineering methodology work irrespective of the amount.**
- (l) the proposed methodology and programme of construction, backed with equipment planning and deployment, duly supported with broad calculations and quality control procedures proposed to be adopted, justifying their capability of execution and completion of the work as per technical specifications within the stipulated period of completion as per milestones (for all contracts over Rs.2.5 Crore).

4.4 Bids from Joint ventures are acceptable. **Costing Rs. 20.00 Crore or more** Or Bids from pre-qualified firms or pre-qualified joint-ventures only will be acceptable.

4.4.1 Joint Venture partners would be limited to three (including the lead partner).

4.4.2 One of the partners, who is responsible for performing a key in contract (lead partner of the JV) management or is executing a major component of the proposed contract, shall be nominated as being in charge during Bidding periods and in the event of successful Bid, during contract execution. The partner in charge shall be authorized to incur liabilities and receive instructions for and on behalf of the partner(s) of the Joint Venture. This authorization shall be evidenced by submitting a power of attorney signed by legally authorized signatories of all partners.

4.4.3 All the partners of Joint Ventures shall be, jointly and severally liable, during the Bidding process and for the execution of the contract in accordance with the contract terms, and a statement of this affect shall be included in the authorization. The Bid shall be signed so as to legally bind all the partners, jointly and severally.

Bid security and performance guarantee, as required, will be furnished by the lead partner and Joint Venture partner(s) out of their accounts in proportion to their participation in Joint Venture.

4.4.4. Qualifying criteria for Joint Venture

Joint Venture must comply with the following requirements:-

- (a) The Joint Venture must satisfy collectively the criteria for this purpose the following data of each member of the Joint Venture may be added together to meet the collective qualifying criteria.
 - (i) Annual Turnover (Cl. 4.5 (A) (a) of ITB)
 - (ii) Particular Construction Experience. (Cl. 4.5 (A) (b) of ITB)
 - (iii) Personal Capabilities. (Annexure II)
 - (iv) Equipment Capabilities. (Annexure I)
 - (v) Financial Capabilities [Cl.4.3(g) & Cl.4.3(h) of ITB]

* To be deleted for projects costing Rs. 20 Crores or more

***To be deleted for projects costing less than Rs 50 Crores*

- (b) The Lead partner shall meet the following qualifying criteria in proportion to the partnership in JV but not less than 50%.
 - (i) Annual Turnover. (Cl. 4.5 (A) (a) of ITB)
 - (ii) Particular Construction Experience. (Cl. 4.5 (A) (b) of ITB)
 - (iii) Financial Capabilities. [Cl. 4.3 (g) & 4.3 (h) of ITB]
- (c) Other partner shall meet the following qualifying criteria in proportion to the partnership in JV but not less than 25%.
 - (i) Annual Turnover. (Cl. 4.5 (A) (a) of ITB)
 - (ii) Particular Construction Experience. (Cl. 4.5 (A) (b) of ITB)
 - (iii) Financial Capabilities. [Cl. 4.3 (g) & 4.3 (h) of ITB]

4.4.5 A copy of the Joint Venture Agreement (JVA) entered into between the partner shall be submitted with the application. Alternatively, a letter of Intent to execute a JVA in the event of successful Bid shall be signed by all partner(s) and submitted with the application together with a copy of the proposed agreement. The JVA shall include among other things a Joint Venture's objectives and proposed management structure, the contribution of each partner to the Joint Venture operation, the commitment of the partner to Joint Venture in the event of the default or withdrawal of any partner an arrangement for providing the required indemnities:

- (i) Stepping into the shoes of the existing partner(s) of JV with all liabilities of the existing partners from the beginning of the contract.
- (ii) With the prior approval of the employer.
- (iii) Notwithstanding demarcation or allotment of work between two JV partner(s), JV shall be liable for non-performance of the whole contract irrespective of their demarcation or shared of work.

In case of successful Bid being accepted by employer the payments under the contract will only be made to the JV not to the individual partner(s).

4.4.6 Joint Venture Agreement shall contain a Clause to the effect that their shall be a separate JV Bank Account (distinct from the Bank Account of the individual partners) to which the individual partner shall contribute their share / or working capital.

Joint Venture Agreement shall also contain a Clause to the effect that the financial obligations of the JV shall be discharged through the said JV Bank Account only and also all the payments received or paid by the employer by the JV shall be through that Account alone.

Bids from pre-qualified firms or pre-qualified joint-ventures only will be acceptable**

4.5 A. To qualify for award of the contract, each bidder in its name **must** have in the last five years as referred to in Appendix.

- (a) achieved a minimum annual financial turnover (in all classes of civil engineering construction works only) amount indicated in Appendix in any one year (usually not less than one and a half times the estimated cost of the project);
- (b) satisfactorily completed (not less than 90% of contract value), as a prime contractor (or as a nominated subcontractor, where the subcontract involved execution of all main items of work

described in the bid document, provided further that all other qualification criteria are satisfied) at least :-

(I) **for contract value upto 50 crores:-**

- (i) Three similar works each of value not less than Rs.2,02,98,710.00 (50% of 50% of estimated value of contract) or
- (ii) Two similar works each of value not less than Rs 2,43,58,452.00 (60% of 50% of estimated value of contract) or
- (iii) One similar work of value not less than Rs 3,65,37,678.00 (90% of 50% of estimated value of contract) in the last five years)

Note: Similar works shall mean Construction of Road works and Electrical work. Road works shall mean construction of Road/Drain/Culvert/Bridge/Retaining Wall & Electrical installation work, and out of which one work must be Electrical Work e.i. Street Light Installation with Road work or independently the Central Govt. State Govt. Public Sector Undertaking.

The certificate of completion of above works shall be issued by the officer of the rank not below Executive Engineer.

- (c) Executed in any **one year**, the minimum quantities of the following items of work as indicated in Appendix

Earthwork	5706.00 cum
GSB	439.00 cum
DLC	293.00 cum
PQC	1391.00 cum
PCC /RCC	1489.00 cum
Street Light.	19.00Nos.

(usually 50% of the estimated quantity)

- (d) The contractor should possess required valid electrical license for executing the building electrification works and should have executed similar electrical works for a minimum amount as indicated in Appendix in any one work.

- * (e) The contractor or his identified sub-contractor should possess required valid license for executing the water supply/sanitary engineering works and should have executed similar water supply/sanitary engineering works for a minimum amount as indicated in Appendix in any one work.

- (f) If the work involves Specialized nature of work/ new type of Engineering methodology, the contractor shall produce Experience Certificate for executing the similar nature of work for the minimum amount as indicated in Appendix in any one work.

4.5. B. Each bidder should further demonstrate

- (a) availability (either owned or leased or by procurement against mobilization advances) of the following key and critical equipment for this work:

NOTE: (To be indicated for bids valued over Rs. 2.5 Crore) Based on the studies, carried out by the Engineer the minimum suggested Major equipment to attain the completion of works in accordance with the prescribed construction schedule are shown in the **Annexure-I**

The bidders should, however, undertake their own studies and furnish with their bid, a detailed construction planning and methodology supported with layout and necessary drawings and calculations (detailed) as stated in clause 4.3(C) above to allow the employer to review their proposals. The numbers, types and capacities of each plant/equipment shall be shown in the proposals along with the cycle time for each operation for the given production capacity to match the requirements.

- (b) availability for this work of personnel with adequate experience as required; as per **Annexure-II**.
- (c) liquid assets and/or availability of credit facilities of no less than amount indicated in Appendix (credit lines/letter of credit/certificates from Banks for meeting the funds requirements etc.- usually the equivalent of the estimated cash flow for 3 months in peak construction period.)
- C. To qualify for a package of contracts made up of this and other contracts for which bids are invited in the IFB**, the bidder must demonstrate having experience and resources sufficient to meet the aggregate of the qualifying criteria for the individual contracts.

** Delete, if not applicable.*

4.6 Sub-contractors' experience and resources shall not be taken into account in determining the bidder's compliance with the qualifying criteria except to the extent stated in 4.5(A) above.

4.7. Bidders who meet the minimum qualification criteria will be qualified only if their available bid capacity is more than the total bid value. The available bid capacity will be calculated as under:

$$\text{Assessed Available Bid capacity} = (A * N * 2 - B)$$

where

A = Maximum value of civil engineering works executed in any one year during the last five years (updated to the price level of the year indicated in Appendix) taking into account the completed as well as works in progress.

N = Number of years prescribed for completion of the works for which bids are invited.

B = Value (updated to the price level of the year indicated in Appendix) of existing commitments and on-going works to be completed during the next **01 years** (period of completion of the works for which bids are invited)

4.8. Even though the bidders meet the above qualifying criteria, they are subject to be disqualified if they have :

- made misleading or false representations in the forms, statements and attachments in proof of the qualification requirements; and/or

- record of poor performance such as abandoning the works, not properly completing the contract, inordinate delays in completion, litigation history, or financial failures etc.; and/or
- participated in the previous bidding for the same work and had quoted unreasonable bid prices **(too High or too Low)** and could not furnish rational justification to the employer.

5. One Bid per Bidder

5.1. Each bidder shall submit only one bid for one package. A bidder who submits or participates in more than one Bid (other than as a subcontractor or in cases of alternatives that have been permitted or requested) will cause all the proposals with the Bidder’s participation to be disqualified.

6. Cost of Bidding

6.1 The bidder shall bear all costs associated with the preparation and submission of his Bid, and the Employer will in no case be responsible and liable for those costs.

7. Site Visit

7.1. The Bidder, at the Bidder’s own responsibility and risk is encouraged to visit and examine the Site of Works and its surroundings and obtain all information that may be necessary for preparing the Bid and entering into a contract for construction of the Works. The costs of visiting the Site shall be at the Bidder’s own expense.

** Delete, if not applicable.*

B. BIDDING DOCUMENTS

8. Content of Bidding Documents

8.1. The set of bidding documents comprises the documents listed below and addenda issued in accordance with Clause 10:

Section	Particulars	Volume No.
	Invitation for Bids	I
1	Instruction to Bidders	
2	Qualification Information, and other forms	
3	Conditions of contract	
4	Contract Data	II
5	Technical Specifications	
6	Form of bid	III
7	Bill of Quantities	
8	Securities and other forms	IV
9	Drawings	
10	Documents to be furnished by bidder	V

8.2. Each of the Volumes I, II, III, IV will be available online on website <http://jharkhandtenders.gov.in> for bidder(s). Documents to be submitted by the bidder(s) in compliance to section 2 will be prepared by him and submitted online as per instruction given in addendum to ITB.

8.3. The bidder is expected to examine carefully all instructions, conditions of contract, contract data, forms, terms, technical specifications, bill of quantities, forms, Annexes and drawings in the Bid Document. Failure to comply with the requirements of Bid Documents shall be at the bidder's own risk. Pursuant to clause 26 hereof, bids which are not substantially responsive to the requirements of the Bid Documents shall be rejected.

9. Clarification of Bidding Documents

9.1. A prospective bidder requiring any clarification of the bidding documents may notify the Employer in writing or by cable (hereinafter "cable" includes telex, facsimile **and email**) at the Employer's address indicated in the invitation to bid. The Employer will respond to any request for clarification which he received earlier than 15 days prior to the deadline for submission of bids. Copies of the Employer's response will be forwarded to all purchasers of the bidding documents, including a description of the enquiry but without identifying its source.

9.1.2 Bidding document is available on Internet on official website of Govt. of Jharkhand (www.jharkhandtenders.gov.in). It can be downloaded and submitted to the competent authority with the cost of document in the shape of Demand draft as stated in IFB along with Bid Security money in time.

9.2 *Pre-bid meeting. *(Deleted)

9.2.1. In case of projects of more than 20 crores the bidder or his official representative is invited to attend a pre-bid meeting which will take place at the address, venue, time and date as indicated in appendix.

9.2.2. The purpose of the meeting will be to clarify issues and to answer questions on any matter that may be raised at that stage.

9.2.3 The bidder is requested to submit any questions in writing or by cable (**cable as defined in** to reach the Employer not later than one week before the meeting.

9.2.4. Minutes of the meeting, including the text of the questions raised (without identifying the source of enquiry) and the responses given will be transmitted without delay to all purchasers of the bidding documents. Any modification of the bidding documents listed in sub-Clause 8.1 which may become necessary as a result of the pre-bid meeting shall be made by the Employer exclusively through the issue of an Addendum pursuant to Clause 10 and not through the minutes of the pre-bid meeting.

9.2.5. Non-attendance at the pre-bid meeting will not be a clause for disqualification of a bidder.

10. Amendment of Bidding Documents

- 10.1. Before the deadline for submission of bids, the Employer may modify the bidding documents by issuing addenda.
- 10.2. Any addendum thus issued shall be part of the bidding documents and shall be communicated in writing or by cable to all the purchasers of the bidding documents. Prospective bidders shall acknowledge receipt of each addendum in writing or by cable to the Employer. The Employer will assume no responsibility for postal delays.
- 10.3. To give prospective bidders reasonable time in which to take an addendum into account in preparing their bids, the Employer may, at his discretion, extend as necessary the deadline for submission of bids, in accordance with Sub-Clause 20.2 below.

** Delete, if not applicable.*

C. PREPARATION OF BIDS

11. Language of the Bid

- 11.1. All documents relating to the bid shall be in the English language.

12. Documents Comprising the Bid

The bid to be submitted by:

- 12.1. The bid shall be submitted by the bidder online as per instruction contained in addendum to ITB.
- 12.2. The bidder shall submit bid online.
- 12.3. Following documents, which are not submitted with the bid, will be deemed to be part of the bid.

Section	Particulars	Volume No.
	Invitation for Bids(IFB)	Volume I
1	Instruction to Bidders	
3	Conditions of Contract	
4	Contract Data	
5	Specifications	Volume II
8	Drawings	Volume IV

13. Bid Prices

- 13.1. The contract shall be for the whole works as described in Sub-Clause 1.1. based on the priced Bill of Quantities submitted by the Bidder.
- 13.2. The bidder shall fill in rates in figures only as the rate in words will be generated automatically in the BOQ template. Items for which no rate or price is entered by the bidder will not be paid for by the Employer when executed and shall be deemed covered by the other rates and prices in the Bill of Quantities.

- 13.3. All duties, taxes, and other levels payable by the contractor under the contract, or for any other cause shall be included in the rates, prices and total Bid Price submitted by the Bidder.
- 13.4.* The rates and prices quoted by the bidder shall be fixed for the duration of the Contract and shall not be subject to adjustment **on** any account (For contracts upto 12 months period.)

OR

- 13.4* The rates and prices quoted by the bidder are subject to adjustment during the performance of the Contract in accordance with the provisions of **Clause 47** of the Conditions of Contract (For contracts more than 12 months period).

14. Currencies of Bid and Payment

- 14.1. The unit rates and the prices shall be quoted by the bidder entirely in Indian Rupees. All payment shall be made in Indian Rupees.

15. Bid Validity

- 15.1. Bids shall remain valid for a period not less than **120 days** after the deadline date for bid submission specified in Clause 20. A bid valid for a shorter period shall be rejected by the Employer as non-responsive. In case of discrepancy in bid validity period between that given in the undertaking pursuant to clause 12.1 (v) and the Form of Bid submitted by the bidder, the latter shall be deemed to stand corrected in accordance with the former and the bidder has to provide for any additional security that is required.
- 15.2. In exceptional circumstances, prior to expiry of the original time limit, the Employer may request that the bidders may extend the period of validity for a specified additional period. The request and the bidders' responses shall be made in writing or by cable. A bidder may refuse the request without forfeiting his bid security. A bidder agreeing to the request will not be required or permitted to modify his bid, but will be required to extend the validity of his bid security for a period of the extension, and in compliance with Clause 16 in all respects.

15.3 Deleted

** Choose one and delete the other*

- 15.4 Bid evaluation will be based on the bid prices without taking into consideration the above correction.

16. * Bid Security

- 16.1. The Bidder shall furnish, as part of his Bid, a Bid security in the amount as shown in column 4 of the table of IFB for this particular work. This bid security shall be in favour of Employer as named in Appendix and may be in one of the following forms:
- a. Receipt in challan of cash deposit in the Govt. Treasury in India.
 - b. Deposit-at-call receipt from any of the Scheduled Bank situated **within the territory of India.**
 - c. Indian Post Office/**Fixed Deposit**/National Savings Certificates duly endorsed by the competent Postal Authority in India.

- d. Bank Guarantee from any Scheduled Indian Bank from any of the branches of Scheduled Bank situated within the territory of India in the format given in Section 8.
- e. Fixed deposit receipt, a certified cheque or an irrevocable letter of credit, issued by any scheduled Indian Bank approved by the Reserve Bank of India.
- 16.2. Bank guarantees (and other instruments having fixed validity) issued as surety for the bid shall be valid for 45 days beyond the validity of the bid.
- 16.3. Any bid not accompanied by an acceptable Bid Security and not secured as indicated in Sub-Clauses 16.1 and 16.2 above shall be rejected by the Employer as non-responsive.
- 16.4. The Bid security of unsuccessful bidders will be returned within 28 days of the end validity period specified in sub-Clause 15.1.
- 16.5. The Bid security of the successful bidder will be discharged when the bidder has signed the Agreement and furnished the required Performance Security.
- 16.6. The Bid security may be forfeited
 - (a) if the Bidder withdraws the Bid after Bid opening during the period of Bid validity;
 - (b) if the Bidder does not accept the correction of the Bid Price, pursuant to Clause 27; or
 - (c) in the case of a successful Bidder, if the Bidder fails within the specified time limit to
 - (i) sign the Agreement; or
 - (ii) furnish the required Performance Security.

17. *Alternative proposals by Bidders

- 17.1. Bidders shall submit offers that fully comply with the requirements of the bidding documents, including the conditions of contract (including mobilization advance or time for completion), basic technical design as indicated in the drawing and specifications. Conditional offer or alternative offers will not be considered further in the process of tender evaluation.

18. Format and Signing of Bid

- 18.1 The bidder shall submit the bids as per addendum to instruction to bidder.
- 18.2. Instruction to Bidders(for SBD contract) to be followed. Bids submitted online has to be digitally signed by the bidder.
- 18.3 Bidders shall follow the Method of submission of bid as mentioned in Instruction to Bidders(for SBD contract)

** Delete, if not applicable.*

D. SUBMISSION OF BIDS

19. (A) Instructions & documents to be furnished for online bidding

- 19.1 Guidelines for online submission of bids can be downloaded from the website <http://jharkhandtenders.gov.in>
- 19.2 Interested bidders can download the bid from the website <http://jharkhandtenders.gov.in>
- 19.3 Bidders in order to participate in the bidding process have to get 'Digital Signature Certificate (DSC)' as per Information Technology Act-2000 to participate in online bidding. This certificate will be required for digitally signing the bid. Bidders can get the above mentioned digital signature certificate from any approved vendors (CCA). Bidders, who already possess valid Digital Certificates, need not procure new Digital Certificate.
- 19.4 Bidders have to submit their bids online in electronic format with digital Signature. Bids without digital signature will not be accepted. No proposal will be accepted in physical form.
- 19.5 Bids will be opened online as per time schedule mentioned in the Invitation for Bids (IFB).
- *19.6 Bidders should be ready with the scanned copies of cost of documents & bid security as specified in the tender document. Before submission of bids online, bidders must ensure that scanned copies of all the necessary documents have been attached with bid.
- *19.7 Bidders have to produce original Demand Draft towards cost of Bid Document & bid security as mentioned in the Invitation for Bids (IFB) to the Nodal Officer, e-Procurement Cell during the period & time as mentioned in the I.F.B. failing which bid will not be accepted. The details of cost of documents, bid security specified in the tender documents should be the same as submitted online (scanned copies), otherwise bid will summarily be rejected.
- 19.8 Uploaded documents of successful bidder will be verified with the original before signing the agreement. The successful bidder has to provide the originals to the concerned authority.
- 19.9 The department will not be responsible for delay in online submission of bids due to any reason, what so ever.
- 19.10 All required information for bid must be filled and submitted online.
- 19.11 Other details can be seen in the bidding documents.
- 19.12 Only online withdrawal or modification of bids, if any, in pursuance of relevant clauses of the SBD is acceptable.

19. (B) Details of documents to be furnished for online bidding

1. **Scanned copies of the following documents to be up-loaded in .pdf format on the website <http://jharkhandtenders.gov.in> in technical bid folder.**
 - i. Qualification information and supporting documents as specified in Section-2 of SBD.
 - ii. Certificates, undertakings, affidavits as specified in Section-2.
 - iii. Any other information pursuant to Clause-4.2 of ITB.
 - iv. Undertakings that the bid shall remain valid for the period specified in Clause-15.1 of ITB.
2. **Scanned copies of the following documents to be up-loaded on the website <http://jharkhandtenders.gov.in> in financial bid folder.**
 - Form of bid has specified in Section-6 in pdf format.
3. Duly filled in & digitally signed BOQ.
4. Uploaded documents of successful bidder will be verified with the original before signing the agreement. The successful bidder has to provide the originals to the concerned authority on receipt of such a letter, which will be sent through registered post or speed post or delivered by hand or E-mail.
5. Each uploading shall be digitally signed by the bidders.

20. Deadline for Submission of the Bids

- 20.1. Bidders shall follow the Method of submission of bid as mentioned in Instruction to Bidders (for SBD contract)
- 20.2. The Employer may extend the deadline for submission of bids by issuing an amendment in accordance with Clause 10, in which case all rights and obligations of the employer and the bidders previously subject to the original deadline will then be subject to the new deadline.

21. Late Bids

- 21.1. Any Bid received by the Employer after the deadline prescribed in Clause 20 will be returned to the bidder.

22. Modification and Withdrawal of Bids

- 22.1. Bidders may modify or withdraw their bids by giving notice in writing before the deadline prescribed in Clause 20 or pursuant to Clause 23.

- 22.2. Bidders shall follow the Method of submission **modification & withdrawal** of bid as mentioned in Instruction to Bidders (for SBD contract)
- 22.3. No bid may be modified after the deadline for submission of Bids except in pursuance of Clause 23.
- 22.4. Withdrawal or modification of a Bid between the deadline for submission of bids and the expiration of the original period of bid validity specified in Clause 15.1 above or as extended pursuant to clause 15.2 may result in the forfeiture of the Bid security pursuant to Clause- 16.

E. BID OPENING AND EVALUATION

23. Bid Opening

- 23.1 The Employer will open all the Bids submitted online including modification made pursuant to Clause 22, in the manner specified in Clause 20 and 23.3. In the event of the specified date of Bid opening being declared a holiday for the Employer, the Bids will be opened at the appointed time and location on the next working day. A notice for the same shall be posted on the website.
- 23.2. Withdrawn bids shall be opened and read out first. Bids for which an acceptable notice of withdrawal has been submitted pursuant to clause 22 shall not be opened.
- 23.3 “Technical bid” shall be opened first. The amount, form and validity of the bid security furnished with each bid will be announced. If the bid security furnished does not conform to the amount and validity period as specified in the Invitation for Bid (ref. Column 4 and paragraph 3), and has not been furnished in the form specified in Clause 16, the said bid shall not be opened/ processed further.
- 23.4.(i) Subject to confirmation of the bid security by the issuing bank, the bids accompanied with valid security will be taken up for evaluation with respect to the Qualification Information and other information furnished in Part I of the bid pursuant to clause 12.1.
- (ii) After receipt of confirmation of the bid security, the bidder will be asked in writing/e-mail (usually within 10 days of opening of the Technical Bid) to clarify or modify his technical bid, if necessary, with respect to any rectifiable defects.
- (iii) The bidders will respond by e-mail in not more than 7 days of issue of the clarification letter, which will also indicate the date, time and venue of opening of the Financial Bid (usually on the 21st day of opening of the Technical bid)
- (iv) Immediately (usually within 3 or 4 days), on receipt of these clarifications the Evaluation Committee will finalize the list of responsive bidders whose financial bids are eligible for consideration.
- 23.5. If, as a consequence of the modifications carried out by the bidder in response to sub-clause 23.4, the bidders desire to modify their financial bid, they will submit the modification online before the opening of the financial bid as intimated in the clarification letter (refer sub-clause 23.4).
- 23.6. At the time of opening of “Financial Bid”, the names of the bidders found responsive in accordance with Clause 23.4(iv) will be announced. The bids of only these bidders will be opened. The remaining bids will remain unopened. The responsive Bidders’ names, the bid prices, the total amount of each bid, any discounts, Bid Modifications and withdrawals, and such other details as the Employer may consider appropriate, will be announced by the

Employer at the opening. Any Bid price or discount, which is not read out and recorded, will not be taken into account in Bid Evaluation.

- 23.7. In case bids are invited in more than one package, the order for opening of the “Financial Bid” shall be that in which they appear in the “Invitation For Bid”.
- 23.8. The Employer shall prepare minutes of the Bid opening, including the information disclosed to those present in accordance with Sub-clause 23.6.

24. Process to be Confidential

- 24.1 Information relating to the examination, clarification, evaluation, and comparison of Bids and recommendations for the award of a contract shall not be disclosed to Bidders or any other persons not officially concerned with such process until the award to the successful Bidder has been announced. Any effort by a Bidder to influence the Employer’s processing of Bids or award decisions may result in the rejection of his Bid.

25. Clarification of Financial Bids

- 25.1. To assist in the examination, evaluation, and comparison of Bids, the Employer may, at his discretion, ask any Bidder for clarification of his Bid, including breakdowns of unit rates. The request for clarification and the response shall be in writing or by cable, but no change in the price or substance of the Bid shall be sought, offered, or permitted except as required to confirm the correction of arithmetic errors discovered by the Employer in the evaluation of the Bids in accordance with Clause- 27.
- 25.2. Subject to sub-clause 25.1, no Bidder shall contact the Employer on any matter relating to his bid from the time of the bid opening to the time the contract is awarded. If the bidder wishes to bring additional information to the notice of the Employer, it should do so in writing.
- 25.3. Any effort by the Bidder to influence the Employer in the Employer’s bid evaluation, bid comparison or contract award decisions may result in the rejection of the Bidders’ bid.

26. Examination of Bids and Determination of Responsiveness

- 26.1. During the detailed evaluation of “Technical Bids”, the Employer will determine whether each Bid (a) meets the eligibility criteria defined in Clause 3 and 4; (b) has been properly signed; (c) is accompanied by the required securities and; (d) is substantially responsive to the requirements of the Bidding documents. During the detailed evaluation of the “Financial Bid”, the responsiveness of the bids will be further determined with respect to the remaining bid conditions, i.e., priced bill of quantities, technical specifications, and drawings.
- 26.2. A substantially responsive “Financial Bid” is one which conforms to all the terms, conditions, and specifications of the Bidding documents, without material deviation or reservation. A material deviation or reservation is one (a) which affects in any substantial way the scope, quality, or performance of the Works; (b) which limits in any substantial way, inconsistent with the Bidding documents, the Employer’s rights or the Bidder’s obligations under the Contract; or (c) whose rectification would affect unfairly the competitive position of other Bidders presenting substantially responsive Bids.
- 26.3. If a “Financial Bid” is not substantially responsive, it will be rejected by the Employer, and may not subsequently be made responsive by correction or withdrawal of the non-conforming deviation or reservation.

27. Correction of Errors

- 27.1. “Financial Bids” determined to be substantially responsive will be checked by the Employer for any arithmetical errors. Errors will be corrected by the Employer as follows:
- (a) where there is a discrepancy between the rates in figures and in word, the rate in words will govern; and
 - (b) where there is a discrepancy between the unit rate and the line item total resulting from multiplying the unit rate by the quantity, the unit rate as quoted will govern.
- 27.2. The amount stated in the “Financial Bid” will be corrected by the Employer in accordance with the above procedure and the bid amount adjusted with the concurrence of the Bidder in the following manner:
- (a) If the Bid price increases as a result of these corrections, the amount as stated in the bid will be the ‘bid price’ and the increase will be treated as rebate;
 - (b) If the bid price decrease as a result of the corrections, the decreased amount will be treated as the ‘bid price’. Such adjusted bid price shall be considered as binding upon the Bidder. If the Bidder does not accept the corrected amount the Bid will be rejected, and the Bid security may be forfeited in accordance with Sub-clause 16.6(b)

28. Deleted.

29. Evaluation and Comparison of Financial Bids

- 29.1. The Employer will evaluate and compare only the Bids determined to be substantially responsive in accordance with Sub-Clause 26.2.
- 29.2. In evaluating the Bids, the Employer will determine for each Bid the evaluated Bid Price by adjusting the Bid Price as follows:
- (a) making any corrections for errors pursuant to clause 27; or
 - (b) making an appropriate adjustments for any other acceptable variations, deviations; and
 - (c) making appropriate adjustments to reflect discounts or other price modifications offered in accordance with Sub-Clause 23.6
- 29.3. The Employer reserves the right to accept or reject any variation or deviation. Variations and deviations and other factors, which are in excess of the requirements of the bidding documents or otherwise result in unsolicited benefits for the Employer, shall not be taken into account in Bid evaluation.
- 29.4. The estimated effect of the price adjustment conditions under Clause 47 of the Conditions of Contract, during the period of implementation of the Contract, will not be taken into account in Bid evaluation.
- 29.5. If the Bid on the successful Bidder is seriously unbalanced in relation to the Engineer’s estimate of the cost of work to be performed under the contract, the Employer may require the Bidder to produce detailed price analyses for any or all items of the Bill of Quantities, to demonstrate the internal consistency of those prices with the construction methods and schedule proposed. After evaluation of the price analyses, the employer may require that the amount of the performance security set forth in clause 34 be increased at the expense of the successful Bidder to a level sufficient to protect the Employer against financial loss in the event of default of the successful Bidder under the Contract.

29.6 A bid which contains several items in the Bill of Quantities which are unrealistically priced low and which cannot be substantiated satisfactorily by the bidder, may be rejected as non-responsive.

30. Deleted.

F. AWARD OF CONTRACT

31. **Award of Criteria**

31.1. Subject to Clause 30, the Employer will award the Contract to the Bidder whose Bid has been determined

(i) to be substantially responsive to the bidding documents and who has offered the lowest evaluated Bid Price; and

(ii) to be within the available bid capacity adjusted to account for his bid price which is evaluated the lowest in any of the packages opened earlier than the one under consideration. In no case, the contract shall be awarded to any bidder whose available bid capacity is less than the evaluated bid price, even if the said bid is the lowest evaluated bid. The contract will in such cases be awarded to the next lowest bidder at his evaluated bid price.

32. **Employer's Right to Accept or Reject any Bid or all Bids along with blacklisting for concealing any fact. In case the Bidder (By itself or in a Consortium or JV) is found to have been debarred or blacklisted by Union Government or any State Government or any Undertaking /PSU of the Union Government or any State Government.**

32.1. Notwithstanding Clause 31, the Employer reserves the right to accept or reject any Bid to cancel the bidding process and reject all bids, at any time prior to the award of Contract, without thereby incurring any liability to the affected Bidder or Bidders or any obligation to inform the affected Bidder or Bidders of the grounds for the Employer's action.

32.2 Bidder would give an undertaking mentioning all the ongoing projects in detail. If it is found that any bidder has not mentioned even one ongoing project the bid will be rejected, if due to this the Bid capacity gets manipulated.

32.3 After Award of contract, if the Bidder/**Consultant** is found to have concealed any fact relevant to projects, the employer may blacklist the Bidder/**Consultant** or Bidders/**Consultants** within 180 days, with due process as -

i) **1 Year Blacklisting for the Project Cost upto Rs. 2.50 Crore.**

ii) 3 Years Blacklisting for the Project Cost Rs. 2.50 Crore to Rs. 10.00 Crore

iii) 5 Years Blacklisting for the Project Cost above Rs. 10.00 Crore to Rs. 100.00 Crore

iv) 10 Years Blacklisting for the Project Cost above Rs. 100.00 Crore

32.3 A. **For the consideration of liability against any Bidder or Consultant as the case may be, the value of the Agreement with/the work order issued to the concerned bidder or consultant shall be taken into account.**

33. **Notification of Award and Signing of Agreement**

33.1. The Bidder whose Bid has been accepted will be notified of the award by the employer prior to expiration of the Bid validity period by cable, telex or facsimile confirmed by registered letter. This letter (hereinafter and in the Conditions of Contract called the "Letter of Acceptance") will state the sum that the Employer will pay the contractor in consideration of the execution, completion, and maintenance of the Works by the contractor as prescribed by the contract (hereinafter and in the contract called the "Contract Price").

- 33.2. The notification of award will constitute the formation of the Contract, subject only to the furnishing of a performance security in accordance with the provisions of Clause- 34.
- 33.3. The Agreement will incorporate all agreements between the Employer and the successful Bidder. It will be signed by the Employer and sent to the successful Bidder, within 28 days following the notification of award along with the Letter of Acceptance. Within 21 days of receipt, the successful Bidder will sign the Agreement and deliver it to the Employer.
- 33.4. Upon the furnishing by the successful Bidder of the Performance Security, the Employer will promptly notify the other Bidders that their Bids have been unsuccessful.
- 33.5. Successfully bidder should provide well-furnished office for JIADA official on site. Successfully bidder should also provide one SUV car with driver and fuel for site inspection.

34. Performance Security

- 34.1. Within 21 days of receipt of the Letter of Acceptance, the successful Bidder shall deliver to the Employer a Performance security in any of the forms given below for an amount equivalent to **2%** of the Contract price plus additional security **either (i) unbalanced Bids or (ii) in case of applicability of Sankalp No-2146 (s) dt. 09.09.2020 of Road Construction Department, Government of Jharkhand** for unbalanced Bids in accordance with clause 29.5 of ITB and Clause 52 of Conditions of Contract:

A bank guarantee from any of the branches of **Scheduled Bank** situated within **territory of India** in the form given in Section 8; or Certified Cheque/Bank Draft as indicated in Appendix.

- 34.2. If the performance security is provided by the successful Bidder in the form of a Bank Guarantee, it shall be issued from any of the branches of **Scheduled Bank** situated within **territory of India**.
- 34.3. Failure of the successful Bidder to comply with the requirements of Sub-Clause 32.1 shall constitute grounds for cancellation of the award and forfeiture of the Bid Security.

35. Advance Payment and Security * Deleted.

- 35.1. The Employer will provide an Advance Payment on the Contract Price as stipulated in the Conditions of Contract, subject to maximum amount, as stated in the Contract Data.

36. Deleted.

37. Corrupt or Fraudulent Practices

- 37.1. The Employer will reject a proposal for award if it determines that the Bidder recommended for award has engaged in corrupt or fraudulent practices in competing for the contract in question and will declare the firm ineligible, either indefinitely or for a stated period of time, to be awarded a contract with National Highways Authority of India/State PWD and any other agencies, if at any time determines that the firm has engaged in corrupt or fraudulent practices in competing for the contractor, or in execution.
- 37.2. Furthermore, Bidders shall be aware of the provision stated in Sub-Clause 23.2 and Sub-Clause 59.2 of the Conditions of Contract.

APENDIX to ITB

Clause Reference with respect to
Section-I

1. Name of the Employer is **Managing Director, Jharkhand Industrial area Development Authority (JIADA)**. [C1. 1.1]
2. The last five years

2019- 2020
2020- 2021
2021- 2022
2022-2023
2023-2024
3. This annual financial turn over amount is Rs. 8,11,94,840.00 [C1.4.5A(a)]
(Rupees Eight crore Eleven lakh Ninety Four Thousand Eight Hundred Forty only) (in words)
4. 50% of work Value is Rs. 4,05,97,420.00 [C1.4.5A(b)]
(Rs. Four crore Five lakh Ninety Seven thousand Four Hundred Twenty only)
(in Word)
5. Quantities of work are in Appendix: [C1.4.5A(c)]

-Earthwork in excavation	5706.00 cum
- GSB	439.00 cum
-DLC	293.00 cum
- PQC	1391.00 cum
- PCC /RCC	1489.00 cum
-Street Light	19.00Nos.
6. The cost of electric work is **Rs. 11,02,116.00** [C1. 4.5A(d)]
(Rs. Eleven lakh Two thousand one Hundred Sixteen only) (in words)

[C1.4.5A(e)]
7. Liquid assets and/or availability of credit facilities is **Rs. 81,12,000.00/-** [C1.4.5B(c)]
(Rs. Eighty One lakh Twelve thousand only)
(in words)
8. Price level of the financial year **2023-24** [C1. 4.7]

[C1.9.2.1]
9. The Technical bid will be opened at e-Procurement cell, JIADA, Ranchi [C1 .23.1.]

Address of the Employer- JIADA, 3rd floor, New JIADA Building, Industrial area, Namkum, Ranchi-834010

10. Identification:

[C1. 9.2(b)]

Bid for Construction of Basic Infrastructures (Such as Roads, drain, Utility duct, Street Light etc.) of international Level for Hazaribagh industrial Area JIADA. (Name of Contract) Bid reference No **JIADA/SBD/03/Hazaribagh/2024-25** (insert number)
Do not open before **18.10.2024 at 3.30 P.M.** (time and date)

14. The bid should be submitted online lasted by **16.10.2024 upto 5.00 P.M.** [C1. 20.1(a)]

15. The bid will be opened at Office of the Secretary JIADA,
Ranchi on **18.10.2024 at 3 :30 P.M.** (Date, Time). [C1.23.1]

16. The Name of Dispute Review Expert is Secretary , **JIADA, [C1.36.1]**

17. Escalation factors (for the cost of works executed and financial figure to a common base value for works completed)

Years before	Multiply factor
One	1.1
Two	1.21
Three	1.33
Four	1.46
Five	1.61

ANNEXURE-I

<u>Sl. No</u>	<u>Type of Equipment</u>	<u>Maximum age as on 01.01.2024 (Years)</u>	<u>Contract Package Size</u>		
			Up to Rs. 30 Cr.	Rs. 31-50 Cr.	Rs. 51 Cr & above
1	Motor Grader	5	2	3	5
2	Dozer	5	1	1	2
3	Front and Loader	5	1	2	3
4	Smooth Wheeled Roller	5	2	2	3
5	Vibrator Roller	5	1	1	2
6	Hot Mix Plant with Electronic Controls (Minimum 80-100 TPH Capacity)	5	1	1	2
7	Paver Finisher with Electronic Sensor	5	1	1	2
8	Water Tanker	5	2	3	4
9	Bitumen Sprayer	5-7	1	1	2
10	Tandem Roller	5	1	2	2
11	Concrete Mixes with Integral Weigh Batching facility	5	1	1	1
12	Concrete Batching and Mixing Plant (Minimum Capacity- 15 m ³ /hour)	5	-	-	1
	Total		14	18	29

ANNEXURE-II

<u>Sl. No</u>	<u>Personnel</u>	<u>Qualification</u>	<u>Contract Package Size</u>		
			Up to Rs. 30 Cr.	Rs. 31-50 Cr.	Rs. 51 Cr & above
1	Project Manager	B.E. Civil + 15 Years Exp. (5 years as Manager)	1 No.	1 No.	1 No.
2	Site Engineer	B.E. Civil + 10 Years Exp. (5 years in Road Construction)	1 No.	2 No.	4 No.
3	Plant Engineer	B.E. Mech + 10 Years Exp. Or Dip. Mech. + 15 years Exp.	1 No.	1 No.	2 No.
4	Quantity Surveyor	B.E. Civil + 7 Years Exp. Or Dip. Civil + 10 years Exp.	1 No.	1 No.	2 No.
5	Soil & Material Engineer	B.E. Civil + 10 Years Exp.	1 No.	1 No.	2 No.
6	Survey Engineer	B.E. Civil + 5 Years Exp. Or Dip. Civil + 8 years Exp.	1 No.	1 No.	2 No.
	Total		6	7	13

SECTION 2

QUALIFICATION INFORMATION

QUALIFICATION INFORMATION

The information to be filled in by the bidder in the following pages will be used for purposes of post qualification as provided for in Clause 4 of the Instructions to Bidders. This information will not be incorporated in the Contract.

1. For Individual Bidders

1.1. Constitution or legal status of Bidder

[Attach copy]

Place of registration: _____

Principal place of business: _____

Power of attorney of signatory of Bid

[Attach]

1.2. Total value of Civil Engineering construction work performed in the last five years (in Rs. Million)**

2018- 2019

2019- 2020

2020-2021

2021-2022

2023-2024

1.3.1. Work performed as prime contractor, work performed in the past as a nominated sub-contractor will also be considered provided the sub-contract involved execution of all main items of work described in the bid document, provided further that all other qualification criteria are satisfied (in the same name) on works of a similar nature over the last five years.**

Project Name	Name of the Employer*	Description of work	Contract No.	Value of Contract (Rs crore)	Date of issue of work order	Stipulated Period of completion	Actual date of completion*	Remarks Explaining Reasons for delay& work Completed

* Attach certificate(s) from the Engineer(s)-in-Charge/EE/Employer

** immediately preceding the financial year in which bids are received.

β Attach certificate from Chartered Accountant.

#1.3.2. Quantities of work executed as prime contractor, work performed in the past as a nominated sub-contractor, will also be considered provided the sub-contract involved execution of all main items of work described in the bid document, provided further that all other qualification criteria are satisfied (in the same name and style) in the last five years:**

Year	Name of the work	Name of the Employer*	Quantity of work performed (cum) @ Remarks		Remarks* (indicate contract Ref)
			Cement Concrete (including RCC & PCC)	Earth Works	
2019- 2020 2020- 2021 2021- 2022 2022-2023 2023-2024					

1.4 Information on Bid capacity (works for which bids have been submitted and works which are yet to be completed) as on the date of this bid.

(A) Existing commitments and on-going works:

Description of works	Place & State	Contract No.	Name & Address of Employer	Value of Contract (Rs Cr)	Stipulated Period of Completion	Value of Works* remaining To be completed (Rs Cr)	Anticipated date of completion
1	2	3	4	5	6	7	8

* Attach certificate(s) from the Engineer(s)-in-Charge/EE/Employer

@ the item of work for which data is requested should tally with that specified in ITB clause 4.5 A(c). ** immediately preceding the financial year in which bids are received .

Delete, if prequalification has been carried out

(B) Works for which bids already submitted:

Description Of work	Place & State	Name & Address of Employer	Estimated value of Works (Rs Cr)	Stipulated period of completion	Date when decision is expected	Remarks If any
1	2	3	4	5	6	7

1.5 Availability of key items of Contractor's Equipment essential for carrying out the Works [ref. Clause 4.5(B)(a). The Bidder should list all the information requested below. Refer also to Sub Clause 4.3(d) of the Instructions to Bidders.

Item of Equipment	Requirement		Availability Proposals			Remarks (from whom to be purchased)
	No.	Capacity	Owned/Leased to be procured	Nos./Capacity	Age/Condition	

1.6 Qualifications and experience of key personnel required for administration and execution of the Contract [Ref. Clause 4.5(B)(b)]. Attach biographical data. Refer also to sub Clause 4.3 (e) of instructions to Bidders and Sub Clause 9.1 of the Conditions of Contract.

Position	Name	Qualification	Year of Experience (General)	Years of experience in the Proposed position
Project manager				
Etc.				

1.7. Proposed sub-contracts and firms involved. [Refer ITB Clause 4.3(k)]

Sanctions of the works	Value of Sub-contract	Sub-contractor (Name & Address)	Experience in similar Work

Attach copies of certificates on possession of valid license for executing water supply/sanitary work/building electrification/Road work/Specialized or New Technical works [Reference Clause 4.5(d), Clause 4.5(e), Clause 4.5A(f) & Clause 4.5A(g)]

*1.8. Financial reports for the last five years: balance sheets, profit and loss statements, auditors' reports (in case of companies/corporation), etc. List them below and attach copies.

1.9. Evidence of access to financial resources to meet the qualification requirements: Cash in hand, lines of credit, etc. List them below and attach copies of support documents.

1.10. Name, address and telephone, telex, and fax numbers of the Bidders' bankers who may provide references if contacted by the Employer.

1.11. Information on litigation history in which the Bidder is involved.

Other Party(ies)	Employer	Cause of Dispute	Amount involved	Remarks showing Present Status

1.12. Statement of compliance under the requirements of Sub Clause 3.2 of the instructions to Bidders. (Name of Consultant engaged for project preparation is **)

1.13. Proposed work methods and schedule. The Bidder should attach descriptions, drawings and charts as necessary to comply with the requirements of the Bidding documents. [Refer ITB Clause 4.1 & 4.3 (1)]

1.14. Programme

1.15. Quality Assurance Programme

2. Additional Requirements.

2.1. Bidders should provide any additional information required to fulfill the requirements of Clause 4 of the Instructions to the Bidders, if applicable.

(i) Affidavit

(ii) Undertaking

*** (iii) Update of original pre qualification application- **Deleted**

*** (iv) Copy of original pre qualification application- **Deleted**

*** (v) Copy of pre qualification letter- **Deleted**

(vi) Copy of letter of association in the form of agreement with subcontractor for the work defined or for any specialize / new engineering methodology work.

* Delete, if pre qualification has been carried out

** Fill the Name of Consultant.

*** Delete, if pre qualification has not been carried out.

**SAMPLE FORMAT FOR EVIDENCE OF ACCESS TO OR
AVAILABILITY OF CREDIT FACILITIES**

(Clause 4.2 (i) OF ITB)

BANK CERTIFICATE

This is to certify that M/s. _____ is a reputed Company with a good financial standing.

If the contract for the work, namely _____ is awarded to the above firm, we shall be able to provide overdraft/credit facilities to the extent of Rs. _____ to meet their working capital requirements for executing the above contract during the contact period.

(Signature)

Name of Bank
Senior Bank Manager
Address of the Bank

AFFIDAVIT

1. I, the undersigned, do hereby certify that all the statements made in the required attachments are true and correct.

2. The undersigned also hereby certifies that neither our firm M/S _____

_____ have abandoned any Department of Jharkhand or any contract awarded to us for such work have been rescinded, during last five years prior to the date of this bid.

3. The undersigned hereby authorize(s) and request(s) any bank, person, firm or corporation to furnish pertinent information deemed necessary and requested by the Department to verify this statement or regarding my (our) competence and general reputation.

4. The undersigned understand and agrees that further qualifying information may be requested, and agrees to furnish any such information at the request of the Department/Project implementing agency.

(Signed by an authorized Officer of the Firm)

Title of Officer

Name of Firm

DATE

UNDERTAKING

I, the undersigned do hereby undertake that our firm M/s _____

_____ would invest a minimum cash up to 25% of the value of the work during implementation of the Contract.

(Signed by an Authorized Officer of the Firm)

Title of Officer

Name of Firm

DATE

SECTION 3
CONDITIONS OF CONTRACT

Conditions of Contract

Table of Contents

	Page No.		Page No.
A. General		C. Quality Control	
1. Definitions	42	33. Identifying Defects	50
2. Interpretation	44	34. Tests	50
3. Language and Law	44	35. Correction of Defects	50
4. Engineer's Decisions	44	36. Uncorrected Defects	50
5. Delegation	44		
6. Communications	44	D. Cost Control	
7. Sub-contracting	44	37. Bill of Quantities	50
8. Other Contractors	45	38. Change in the Quantities	50
9. Personnel	45	39. Variations	51
10. Employer's & Contractor's Risks	45	40. Payments for Variations	51
11. Employer's Risks	45	41. Cash Flow Forecasts	51
12. Contractor's Risks	45	42. Payments Certificates	51
13. Insurance	45	43. Payments	52
14. Site Investigation Reports	46	44. Deleted	52
15. Queries about the Contract Data	46	45. Tax	52
16. Contractor to Construct the Works	46	46. Currencies	52
17. The Works to be Completed by the intended Completion Date	46	47. Price Adjustment	52
18. Approval by the Engineer	46	48. Retention	53
19. Safety	47	49. Liquidated Damages	53
20. Discoveries	47	50. Bonus	54
21. Possession of the Site	47	51. Advance Payment	54
22. Access to the Site	47	52. Securities	55
23. Instructions	47	53. Deleted	55
24. Deleted	47	54. Cost of Repairs	55
25. Deleted	47		
26. Deleted	47	E. Finishing the Contract	
		55. Completion	56
B. Time Control		56. Taking Over	56
27. Programme	48	57. Final Account	56
28. Extension of the Intended Completion Date	48	58. Operating and Maintenance Manuals	56
29. Deleted	49	59. Termination	56
30. Delays Ordered by the Engineer	49	60. Payment upon Termination	57
31. Management Meetings	49	61. Property	58
32. Early Warning	49	62. Release from Performance	58
		F. Special Conditions of Contract	58

CONDITIONS OF CONTRACT

A. GENERAL

1. Definitions

1.1. Terms which are defined in the Contract data are not also defined in the Conditions of Contract but keep their defined meanings. Capital initials are used to identify defined terms.

Bill of Quantities means the priced and completed Bill of Quantities forming part of the Bid.

The **Completion Date** is the date of completion of the Works as certified by the Engineer in accordance with Sub clause 55.1.

The **Contract** is the contract between the Employer and the Contractor to execute, complete and maintain the Works. It consists of the documents listed in Clause 2.3 below.

The **Contract Data** defines the documents and other information which comprise the Contract.

The **Contractor** is a person or corporate body whose Bid to carry out the Works has been accepted by the Employer .

The **Contractor's Bid** is the completed Bidding document submitted by the Contractor to the Employer and includes Technical and Financial bids.

The **Contract Price** is the price state in the Letter of Acceptance and thereafter as adjusted in accordance with the provisions of the Contract.

Days are calendar days; **months** are calendar months.

A **Defect** is any part of the Works not completed in accordance with the Contract. The **Defects Liability Period** is the period named in the contract Data and calculated from the Completion Date.

The **Employer** is **JIADA** (on behalf of Government of Jharkhand) who will employ the contractor to carry out the Works.

The **Employer's representative** will be the SECRETRY JIADA concerned to be notified by the Employer. The Employer's representative will act on behalf of Employer.

The **Engineer** is the person named in the Contract Data (or any other competent person appointed and notified to the contractor to act in replacement of the Engineer) who is responsible for supervising the Contractor, administering the Contract, certifying payments due to the Contractor issuing and valuing Variations to the Contract, awarding extensions of time. *

** For the Road Projects Costing more than Rs. 10 Crore, and the Bridge project costing more than Rs. 5 Crore“ Supervision Consultant” would act as “Engineer” for the project if advised by the Secretary , JIADA . For the Road Project costing between Rs. 2.5 Crores to Rs. 10 Crores and Bridge Project costing between Rs. 2.5 Crores to Rs. 5 Crores and other projects where Supervision consultant will not act as “Engineer” the Employer’s Representative will act as “Engineer”.*

Equipment is the Contractor’s machinery and vehicles brought temporarily to the Site to construct the Works.

The **Initial Contract Price** is the Contract Price listed in the Employer’s Letter of Acceptance.

The **Intended Completion Date** is the date on which it is intended that the Contractor shall complete the Works. The Intended Completion Date is specified in the Contract Data. The Intended Completion date may be revised only by the Engineer by issuing an extension of time.

Materials are all supplies, including consumables, used by the contractor for incorporation in the Works.

Plant is any integral part of the Works which is to have a mechanical, electrical, electronic or chemical or biological function.

The **Site** is the area defined as such in the Contract Data.

Site Investigation Reports are those which were included in the Bidding documents and are factual interpretative reports about the surface and the sub-surface conditions at the site.

Specification means the Specification of the Works included in the Contract and any modification or addition made or approved by the Employer.

The **Start Date** is given in the Contract Data. It is the date when the Contractor shall commence execution of the works. It does not necessarily coincide with any of the Site Possession Dates.

A **Subcontractor** is a person or corporate body who has a contract with the Contractor to carry out a part of the work in the Contract which includes work on the Site.

Temporary Works are works designed, consulted, installed, and removed by the contractor which are needed for construction or installation of the Works.

A **Variation** is an instruction given by the Employer, which varies the works.

The **Works** are what the Contract requires the Contractor to construct, install, and turn over to the Employer, as defined in the Contract Data.

2. Interpretation

- 2.1. In interpreting these Conditions of Contract, singular also means plural, male also means female or neuter, and the other way around. Headings have no significance. Words have their normal meaning under the language of the Contract unless specifically defined. The Engineer will provide instructions clarifying queries about the Conditions of Contract.
- 2.2. If sectional completion is specified in the Contract Data, references in the Conditions of Contract to the Works, the Completion Date, and the Intended Completion Date apply to any Section of the Works (other than references to the Completion date and Intended Completion date for the whole of the works).
- 2.3. The documents forming the Contract shall be interpreted in the following order of priority:
 - (1) Agreement
 - (2) Letter of Acceptance, notice to proceed with the works
 - (3) Contractor's Bid
 - (4) Contract Data
 - (5) Conditions of Contract including Special Conditions of Contract
 - (6) Specifications
 - (7) Drawings
 - (8) Bill of Quantities and
 - (9) Any other document listed in the Contract Data as forming part of the Contract.

3. Language and Law

- 3.1. The language of the Contract and the law governing the contract are stated in the Contract Data.

4. Engineer's Decisions

- 4.1. Except where otherwise specifically stated, the Engineer will decide contractual matters between the Employer and the Contractor in the role representing the Employer.

5. Delegation

- 5.1. The Engineer may delegate any of his duties and responsibilities to other people after notifying the Contractor and may cancel any delegation after notifying the Contractor.

6. Communications

- 6.1. Communications between parties which are referred to in the conditions are effective only when in writing. A notice shall be effective only when it is delivered (in terms of Indian Contract act).

7. Sub-Contracting

- 7.1. The Contractor may sub-contract any portion of work, up to a limit specified in Contract Data, with the approval of the Engineer but may not assign the Contract without the approval of the Employer in writing. Sub-contracting does not alter the Contractor's obligations. Maximum number of Sub Contractor will be two and they will have to meet all qualifying criteria in the ratio of work allotted.

8. Other Contractors

- 8.1. The Contractor shall cooperate and share the site with other contractors, public authorities, utilities, and the employer between the dates given in the Schedule of other Contractors. The contractors shall as referred to in the Contract Data, also provide facilities and services for them as described in the Schedule. The Employer may modify the schedule of other contractors and shall notify the contractor of any such modification.

9. Personnel

- 9.1. The Contractor shall employ the key personnel named in the Schedule of Key Personnel as referred to in the Contract Data to carry out the functions stated in the Schedule or other personnel approved by the Engineer. The Engineer will approve any proposed replacement of key personnel only if their qualification, abilities, and relevant experience are substantially equal to or better than those of the personnel listed in the schedule.
- 9.2. If the Engineer asks the Contractor to remove a person who is a member of the Contractor's staff of his work force stating the reasons the Contractor shall ensure that the person leaves the Site within seven days and has no further connection with the work in the Contract.

10. Employer's and Contractor's Risks

- 10.1. The Employer carries the risks which this Contract states are Employer's risks, and the contractor carries the risks which this Contract states are Contractor's risks.

11. Employer's Risks

- 11.1. The Employer is responsible for the excepted risks which are (a) in so far as they directly affect the execution of the Works in India, the risks of war, hostilities, invasion, act of foreign enemies, rebellion, revolution, insurrection or military or usurped power, civil war, riot commotion or disorder (unless restricted to the Contractor's employees), and contamination from any nuclear fuel or nuclear waste or radioactive toxic explosive; or (b) a cause due solely to the design of the Works, other than the Contractor's design.

12. Contractor's Risks

- 12.1. All risks of loss or damage to physical property and of personal injury and death which arise during and in consequence of the performance of the Contract other than the excepted risks are the responsibility of the Contractor.

13. Insurance

- 13.1 The Contractor shall provide, in the joint names of the Employer and the Contractor, insurance cover from the Start Date to the end of the Defects Liability Period, in the amounts and deductibles stated in the Contract data for the following events which are due to the Contractor's risks:

- (a) loss of or damage to the Works, Plants and Materials;
- (b) loss of or damage to Equipment;
- (c) loss of or damage of property (except the Works, Plant, Materials and Equipment) in connection with the Contract; and personal injury or death.

- 13.2. Policies and certificates for insurance shall be delivered by the Contractor to the Engineer for the Engineer's approval before the Start Date. All such insurance shall provide for compensation to be payable in the types and proportions of currencies required to rectify the loss or damage incurred.

13.3. If the Contractor does not provide any of the policies and certificates required, the Employer may affect the insurance which the Contractor should have provided and recover the premiums the Employer has paid from payments otherwise due to the Contractor or, if no payment is due, the payment of the premiums shall be a debt due.

13.4. Alterations to the terms of an insurance shall not be made without the approval of the Engineer.

13.5. Both parties shall comply with any conditions of the insurance policies.

14. Site Investigation Reports

14.1. The Contractor, in preparing the Bid, shall rely on any site investigation reports referred to in the Contract data, supplemented by any information available to the Bidder.

15. Queries about the Contract Data

15.1. The Engineer will clarify queries on the Contract Data.

16. Contractor to Construct the Works

16.1. The Contractor shall construct and install the Works in accordance with the Technical Specification and Drawings.

17. The Works to be Completed by the Intended Completion date

17.1. The Contractor may commence execution of the Works on the Start Date and shall carry out the Works in accordance with the programme submitted by the Contractor, as updated with the approval of the Engineer, and complete them by the Intended Completion Date.

18. (A) Approval by the Engineer

18.1. The Contractor shall submit Specifications and Drawings, showing the proposed Temporary works to the Engineer, who is to approve them if they comply with the Specifications and Drawings.

18.2. The Contractor shall be responsible for design of Temporary Works.

18.3. The Engineer's approval shall not alter the Contractor's responsibility for design of the Temporary Works.

18.4. The Contractor shall obtain approval of third parties to the design of the Temporary Works where required.

18.5. All drawings prepared by the Contractor for the execution of the temporary or permanent Works, are subject to prior approval by the Engineer before their use.

18. (B) Approval by the Engineer – Design Requirement for Bridge work, Culvert & retaining wall.

(i) Structural design shall be prepared by retired or present professor/ head of the Civil Engineering Department of any IIT or NIT Collage. The name of structural /firm /designer shall be got approved from the department before its actual submission.

(ii) The Design calculations and drawings shall be submitted to the Chief Engineer in quadruplicate for approval within one month issuance of letter of acceptance (LOA). All the RCC works shall be design in accordance with the Indian Standard code practice for (IS Code 456-2000) and Grade of concrete shall be M-20 and M-25 as admissible Reinforcement shall be High strength Deformed TMT 500 HYSD bars as per IS- 1786-1985

- (iii) The Design of Structural is based of following IS code/ Hand Book, IS-456-2000, IS-1893, IS-4326, IS-13920 & SP-34 hand book on concrete reinforcement & detailing of Bureau of Indian Standard.
- (iv) The decision of Engineer-in-charge regarding sound and approved Engineering practice shall be final. **Nothing extra for design shall be paid.**
- (v) Bidders / Vendors may produce/submit the Structural working drawings all the component of the Civil and electrical work to the organization / department prior to the start of the work.

19. Safety

- 19.1. The Contractor shall be responsible for the safety of all activities on the Site.

20. Discoveries

- 20.1. Anything of historical or other interest or of significant value unexpectedly discovered on the site is the property of the Employer. The Contractor is to notify the Engineer of such discoveries and carry out the Engineer's instructions for dealing with them.

21. Possession of the Site

- 21.1. The Employer shall give possession of all parts of the site to the Contractor.

22. Access to the Site

- 22.1. The Contractor shall allow the engineer and any person authorized by the Engineer access to the Site, to any place where work in connection with the contract is being carried out or is intended to be carried out and to any place where materials or plant are being manufactured/ fabricated / assembled for the works.

23. Instructions

- 23.1. The Contractor shall carry out all instructions of the Engineer pertaining to works which comply with the applicable law where the site is located.
- 23.2. The Constructor shall permit the Employer to inspect the Contractor's accounts and records relating to the performance of the Contractor and to have them audited by auditors appointed by the Employer, if so required by the Employer.

24. Deleted.

25. Deleted.

26. Deleted.

B. TIME CONTROL

27. Programme

- 27.1. Within the time stated in the Contract Data the Contractor shall submit to the Engineer for approval a Programme showing the general methods, arrangements, order, and timing for all the activities in the Works along with monthly cash flow forecast.
- 27.2. An update of the Programme shall be a programme showing the actual progress achieved on each activity and the effect of the progress achieved on the timing of the remaining work including any changes to the sequence of the activities.
- 27.3. The Contractor shall submit to the Engineer, for approval, an updated Programme at intervals no longer than the period stated in the Contract data. If the Contractor does not submit an updated Programme within this period, the Engineer may withhold the amount stated in the Contract Data from the next payment certificate and continue to withhold this amount until the next payment after the date on which the overdue Programme has been submitted.
- 27.4. The Engineer's approval of the Programme shall not alter the Contractor's obligations. The Contractor may revise the Programme and submit it to the Engineer again at any time. A revised Programme is to show the effect of Variations and Compensation Events.

28. Extension of the Intended Completion Date

- 28.1 The Engineer shall extend the Intended Completion Date if a Variation as explained in clause 28.1(a) is issued which makes it impossible for Completion to be achieved by the Intended Completion Date without the Contractor taking steps to accelerate the remaining work and which would cause the Contractor to incur additional cost.
- 28.1(a) The Engineer shall also extend the intended completion date in any of the following events:-**
- (i) The employer does not give access to a part of the site by the site possession date stated in the contract data.**
 - (ii) The Engineer does not approve of a subcontract to be let, within 15 days.**
 - (iii) Other contractors, public authorities, utilities or the Employer does not work within the dates and other constraints such as public pretest, unapproachable working site, unforeseen circumstances stated in the Contract, and they cause delay or extra cost to the Contractor.**
 - (iv) The Engineer unreasonably delays issuing a Certificate of completion.**
 - (v) Force majeure (eg. Natural Calamaties or conditions beyond the human control.)**
- 28.2. The Engineer shall decide whether and by how much to extend the Intended Completion date within 21 days of the Contractor asking the Engineer for a decision upon the effect of a Variation and submitting full supporting information. If the Contractor has failed to give early warning of a delay or has failed to

cooperate in dealing with a delay, the delay by this failure shall not be considered in assessing the new Intended Completion Date.

- 28.3. The Engineer shall within 14 days of receiving full justification from the contractor for extension of Intended Completion Date refer to the Employer his decision. The Employer shall in not more than 21 days communicate to the Engineer the acceptance or otherwise of the Engineer's decision.

29. Deleted.

30. Delays Ordered by the Engineer

- 30.1. The Engineer may instruct the Contractor to delay the start or progress of any activity within the Works.

31. Management Meetings

- 31.1. Either the engineer or the Contractor may require the other to attend a management meeting. The business of a management meeting shall to review the plans for remaining work and to deal with matters raised in accordance with the early warning procedure.
- 31.2. The Engineer shall record the business of management meetings and is to provide copies of his record to those attending the meeting and to the Employer. The responsibility of the parties for actions to be taken is to be decided by the Engineer either at the management meeting or after the management meeting and stated in writing to all who attended the meeting.

32. Early Warning

- 32.1. The Contractor is to warn the Engineer at the earliest opportunity of specific likely future events or circumstances that may adversely affect the quality of the work, increase the Contract Price or delay the execution of works. The Engineer may require the Contractor to provide an estimate of the expected effect of the future event or circumstance on the Contract Price and Completion Date. The estimate is to be provided by the Contractor as soon as reasonably possible.
- 32.2. The Contractor shall cooperate with the Engineer in making and considering proposals for how the effect of such an event or circumstance can be avoided or reduced by anyone involved in the work and in carrying out any resulting instruction of the Engineer.

C. QUALITY CONTROL

- 33. Identifying Defects**
- 33.1. The Engineer shall check the Contractor's work and notify the Contractor of any defects that are found. Such checking shall not affect the Contractor's responsibilities. The Engineer may instruct the Contractor to search for a Defect and to uncover and test any work that the Engineer considers may have a Defect.
- 34. Tests**
- 34.1. If the Engineer instructs the Constructor to carry out a test not specified in the Specification to check whether any work has a Defect and the test shows that it does, the Contractor shall pay for the test and any samples.
- 35. Correction of Defects**
- 35.1. The Engineer shall give notice to the contractor of any Defects before the end of the Defects Liability Period, which begins at completion and is defined in the Contract Data. The defects Liability Period shall be extended for as long as defects remain to be corrected.
- 35.2. Every time notice of a defect is given, the Contractor shall correct the notified Defect within the length of time specified by the Engineer's notice.
- 36. Uncorrected Defects**
- 36.1. If the contractor has not corrected a Defect within the time specified in the Engineer's notice, the Engineer will assess the cost of having the Defect corrected, and the Contractor will pay this amount.

D. COST CONTROL

- 37. Bill of Quantities**
- 37.1. The Bill of Quantities shall contain items for the construction, installation, testing, and commissioning work to be done by the Contractor.
- 37.2. The Bill of Quantities is used to calculate the Contract Price. The Contractor is paid for the quantity of the work done at the rate in the Bill of Quantities for each item.
- 38. Changes in the Quantities**
- 38.1. If the final quantity of the work done differs from the quantity in the Bill of Quantities for the particular item by more than 25 percent provided the change exceeds 1% of initial Contract Price, the Engineer shall adjust the rate to allow for the change, duly considering.
- (a) justification for rate adjustment as furnished by the contractor,
 - (b) economics resulting from increase in quantities by way of reduced plant, equipment, and overhead costs,
- 38.2. The Engineer shall not adjust rates from changes in quantities if thereby the

Initial Contract Price is exceeded by more than 15 percent, except with the Prior approval of the Employer

38.3. If requested by the Engineer, the Contractor shall provide the Engineer with a detailed cost breakdown of any rate in the Bill of Quantities.

39. Variations

39.1. All Variations shall be included in updated Programmes produced by the Contractor.

40. Payments for Variations

40.1. The Contractor shall provide the Engineer with a quotation (with breakdown of unit rates) for carrying out the Variation when requested to do so by the Engineer. The Engineer shall assess the quotation, which shall be given within seven days of the request or within any longer period stated by the Engineer and before the Variation is ordered.

40.2. If the work in the Variation corresponds with an item description in the Bill of Quantities and if, in the opinion of the Engineer, the quantity of work above the limit stated in Sub Clause 34.1 or the timing of its execution do not cause the cost per unit of quantity to change, the rate in the Bill of Quantities shall be used to calculate the value of Variation. If the cost per unit of quantity changes, or if the

40.3. Bill of Quantities, the quotation by the contractor shall be in the form of new rates for the relevant items of work. If the Contractor's quotation is unreasonable, the Engineer may order the Variation and make a change to the Contract Price which shall be based on Engineer's own forecast of the effects of the variation on the Contractor's costs.

40.4. The Contractor shall not be entitled to additional payment for costs which could have been avoided by giving early warning.

41. Cash Flow Forecasts

41.1. When the Programme is updated, the contractor is to provide the engineer with an updated cash flow forecast.

42. Payment Certificates

42.1. The Contractor shall submit to the Engineer monthly statements of the estimated value of the work completed less the cumulative amount certified previously.

42.2. The Engineer shall check the Contractor's monthly statement within 14 days and certify the amount to be paid to the Contractor

42.3. The value of work executed shall be determined by the Engineer.

42.4. The value of work executed shall comprise the value of the quantities of the items in the Bill of Quantities completed

42.5. The value of work executed shall include the valuation of Variations.

The Engineer may exclude any item certified in a previous certificate or reduce the proportion of any item previously certified in any certificate in the light of later information

- 43. Payments**
- 43.1. Payments shall be adjusted for deductions for advance payments, retention, other recoveries in terms of contract and taxes at source, as applicable under the law. The Employer shall pay the Contractor the amounts certified by the Engineer within 28 days of the date of each certificate.
If the Employer makes a late payment, the Contractor shall be paid interest on the late payment in the next payment. Interest shall be calculated from the date for which the payment should have been made upto the date when the late payment is made at 12% per annum.
- 43.2. Items of the Works for which no rate or price has been entered in will not be paid for by the Employer and shall be deemed covered by other rates and prices in the Contract.
- 44. Deleted.**
- 45. Tax/GST/other Taxes**
- 45.1. The rates quoted by the Contractor shall be deemed to be inclusive of the GST and other taxes that the Contractor will have to pay for the performance of this Contract. The Employer will perform such duties in regard to the deduction of such taxes at source as per applicable law.
- 45.2. In item in which there is provision of Tax exemption by State govt./GOI, the employer will pay the contractor total amount including the tax. The contractor shall have to deposit the amount of Tax exemption availed in Govt. Treasury and the contractor will be solely responsible for any lapses in Tax deposit.
- 45.3. Service tax has not been considered in this bill of quantity, the same will be reimbursed to the contractor as per prevailing Govt. circular on production of proof of payment by the contractor. **(Deleted)**
- 45.4. The rate is inclusive of 1% labour cess and accordingly the same will be deducted from each bill.
- 46. Currencies**
- 46.1. All payments shall be made in Indian Rupees.
- 47. Price Adjustment-**
- 47.1. Contract Price shall be adjusted for increase or decrease in rates and price of materials in accordance with the following principles and procedures and as per formula given in the contract data:
- (a) The price adjustment shall apply for the projects to be completed in more than 12 months for the work done from the start date given in the contract data upto end of the initial intended completion date or extensions granted by the

Engineer and shall not apply to the work carried out beyond the stipulated time for reasons attributable to the contractor.

- (b) The price adjustment shall be determined during each month from the formula given in the contract data.
- (c) Following expressions and meanings are assigned to the work done during each month:

R = Total value of work done during the month. It will exclude value for works executed under variations for which price adjustment will be worked separately based on the terms mutually agreed.

47.2. To the extent that full compensation for any rise or fall in costs to the contractor is not covered by the provisions of this or other clauses in the contract, the unit rates and prices included in the contract shall be deemed to include amounts to cover the contingency of such other rise or fall in costs.

48. Retention

48.1. The Employer shall retain from each payment due to the Contractor the proportion stated in the Contract Data until Completion of the whole of the Works.

48.2. On Completion of the whole of the Works half the total amount retained is repaid to the Contractor and half when the Defects Liability Period has passed and the Engineer has certified that all Defects notified by the Engineer to the Contractor before the end of this period have been corrected.

48.3. On completion of the whole works, the contractor may substitute retention money with an "on demand" Bank guarantee.

49. Liquidated Damages

49.1 The Contractor shall pay liquidated damages to the Employer at the rate per day stated in the Contract data for each day that the Completion Date is later than the Intended Completion Date (for the whole of the works or the milestones as stated in the contract data). The total amount of liquidated damages shall not exceed the amount defined in the Contract Data. The Employer may deduct liquidated damages from payments due to the Contractor. Payment of liquidated damages does not affect the Contractor's liabilities.

49.2. If the Intended Completion date is extended after liquidated damages have been paid, the Engineer shall correct any over payment of liquidated damages by the Contractor by adjusting the next payment certificate. The Contractor shall be paid interest on the over payment calculated from the date of payment to the date of repayment at the rates specified in Sub Clause 39.1.

49.3. If the Contractor fails to comply with the time for completion as stipulated in the tender, then the contractor shall pay to the employer the relevant sum stated in the Contract Data as Liquidated damages for such default and not as

penalty for everyday or part of day which shall elapse between relevant time for completion and the date stated in the taking over certificate of the whole of the works on the relevant section, subject to the limit stated in the contract data.

The employer may, without prejudice to any other method of recovery deduct the amount of such damages from any monies due or to become due to the contractor. The payment or deduction of such damages shall not relieve the contractor from his obligation to complete the works on form any other of his obligations and liabilities under the contract.

- 49.4. If, before the Time for Completion of the whole of the Works or, if applicable, any Section, a Taking – Over Certificate has been issued for any part of the Works or of a Section, the liquidated damages for delay in completion of the remainders of the Works or of that Section shall, for any period of delay after the date stated in such Taking-Over Certificate, and in the absence of alternative provisions in the Contract, be reduced in the proportion which the value of the part so certified bears to the value of the whole of the Works or Section, as applicable. The provisions of this Sub-Clause shall only apply to the rate of liquidated damages and shall not affect the limit thereof.

50. Bonus- Deleted

- 50.1. If the contractor achieves completion of the whole of the works prior to the Intended Completion date prescribed in Contract Data the Employer shall pay to the contractor a sum stated in Contract Data as bonus for every completed month which shall elapse between the date of completion of all items of works as stipulated in the contract, including variations ordered by the Engineer and the time prescribed in Clause 17.

For the purpose of calculating bonus payments, the time given in the Bid for completion of the whole of the works is fixed and unless otherwise agreed, no adjustments of the time by reason of granting an extension of time pursuant to Clause 28 or any other clause of these conditions will be allowed. Any period falling short of a complete month shall be ignored for the purpose of computing the period relevant for the payment of bonus.

51. Advance Payment * Deleted.

- 51.1. The Employer shall make advance payment to the Contractor of the amounts stated in the Contract Data by the date stated in the Contract Data against provision by the Contractor of an Unconditional Bank Guarantee in a form and by a bank acceptable to the employer in amounts and currencies equal to the advance payment. The guarantee shall remain effective until the advance payment has been repaid, but the amount of guarantee shall be progressively reduced by the amounts repaid by the Contractor. **Interest will be charged @10% Per Annum on the advance payment after six month on the remaining advance.**

51.2. The Contractor is to use the advance payment only to pay for Equipment, Plant and Mobilization expenses required specifically for execution of the works. The Contractor shall demonstrate that advance payment has been used in this way by supplying copies of invoices or other documents.

51.3. The advance payment shall be repaid by deducting proportionate amounts from payments otherwise due to the Contractor, following the schedule of completed percentages of the Works on a payment basis. No account shall be taken of the advance payment or its repayment in assessing valuations of work done, Variations, price adjustments, or Liquidated Damages.

51.4 Deleted

52. Securities

52.1. The Performance Security (including additional security for unbalanced bids) shall be provided to the Employer no later than the date specified in the Letter of Acceptance and shall be issued in an amount and form and by a bank or surety acceptable to the Employer, and denominated in Indian Rupees. The Performance Security shall be valid until a date 28 days from the date of expiry of Defects Liability Period and the additional security for unbalanced bids shall be valid until a date 28 days from the date of issue of the certificate of completion.

The person/persons whose tender(s) may be accepted (hereinafter called the contractor) shall permit Government at the time of making any payment to him for work done under the contract to deduct a sum of 8% (eight percent) from the gross amount of each running bill till full amount of security deposit 10% (ten percent) of agreement values or value of work (whichever is higher) is reached. If value of work exceeds the agreement value, security deposit (10%) will be recovered for the exceeded work.

53. Deleted.

54. Cost of Repairs

54.1. Loss or damage to the Works or Materials to be incorporated in the Works between the Start Date and the end of the defects Correction periods shall be remedied by the Contractor at the Contractor's cost if the loss or damage arises from the Contractor's acts or omissions.

E. FINISHING THE CONTRACT

55. Completion

- 55.1. The Contractor shall request the Engineer to issue a Certificate of Completion of the Works and the Engineer will do so upon deciding that the Work is completed.

56. Taking Over

- 56.1. The Employer shall take over the Site and the Works within seven days of the Engineer issuing a certificate of Completion.

57. Final Account

- 57.1. The Contractor shall supply to the Engineer a detailed account of the total amount that the Contractor considers payable under the contract before the end of the Defects Liability Period. The Engineer shall issue a Defect Liability Certificate and certify any final payment that is due to the Contractor within 56 days of receiving the Contractor's account if it is correct and complete. If it is not, the Engineer shall issue within 56 days a schedule that states the scope of the corrections or additions that are necessary. If the Final Account is still unsatisfactory after it has been resubmitted, the Engineer shall decide on the amount payable to the Contractor and issue a payment certificate, within 56 days of receiving the Contractor's revised account.

58. Operating and Maintenance Manuals

- 58.1. If "as built" Drawings and/or operating and maintenance manuals are required, the Contractor shall supply them by dates stated in the Contract Data.
- 58.2. If the Contractor does not supply the Drawings and/or manuals by the dates stated in the Contract Data, or they do not receive the Engineer's approval, the Engineer shall withhold the amount stated in the Contract Data from payments due to the Contractor.

59. Termination

- 59.1. The Employer or the Contractor may terminate the Contract if the other party causes a fundamental breach of the Contract.
- 59.2. Fundamental breaches of Contract include, but shall not be limited to the following:
- (a) the Contractor stops work for 28 days when no stoppage of work is shown on the current Programme and the stoppage has not been authorized by the Engineer;
 - (b) the Engineer instructs the Contractor to delay the progress of the Works and the instruction is not withdrawn within 28 days;
 - (c) the Employer or the Contractor is made bankrupt or goes into liquidation other than for a reconstruction or amalgamation;

(d) a payment certified by the Engineer is not paid by the Employer to the Contractor within 56 days of the date of the Engineer's certificate;

- i. the Engineer gives Notice that failure to correct a particular Defect is a fundamental breach of Contract and the Contractor fails to correct it within a reasonable period of time determined by the Engineer.
- ii. the Contractor does not maintain a security which is required;
- iii. the Contractor has delayed the completion of works by the number of days for which the maximum amount of liquidated damages can be paid as defined in the Contract data; and
- iv. if the Contractor, in the judgment of the Employer has engaged in corrupt or fraudulent practices in competing for or in executing the Contract.

For the purpose of this paragraph: "corrupt practice" means the offering, giving, receiving or soliciting of anything of value to influence the action of a public official in the procurement process or in contract execution. "Fraudulent practice" means a misrepresentation of facts in order to influence a procurement process or the execution of a contract to the detriment of the Borrower, and includes collusive practice among Bidders (prior to or after bid submission) designed to establish bid prices at artificial non-competitive levels and to deprive the Borrower of the benefits of free and open competition."

- 59.3 When either party to the Contract gives notice of a breach of contract to the Engineer for a cause other than those listed under Sub Clause 59.2. above, the Engineer shall decide whether the breach is fundamental or not.
- 59.4 Notwithstanding the above, the Employer may terminate the Contract for convenience.
- 59.5 If the Contract is terminated the Contractor shall stop work immediately, make the Site safe and secure and leave the Site as soon as reasonably possible.

60. Payment upon Termination

- 60.1 If the Contract is terminated because of a fundamental breach of Contract by the Contractor, the Engineer shall issue a certificate for the value of the work done less advance payments received up to the date of the issue of the certificate, less other recoveries due in terms of the contract, less taxes due to be deducted at source as per applicable law and less the percentage to apply to the work not completed as indicated in the Contract Data. Additional Liquidated Damages shall not apply. If the total amount due to the Employer exceeds any payment due to the Contractor shall be a debt payable to the Employer.
- 60.2 If the Contract is terminated at the Employer's convenience or because of a fundamental Breach of Contract by the Employer, the Engineer shall issue a certificate for the value of the work done, the cost of balance by the contractor and available at site, the reasonable cost of removal of Equipment, a repatriation of the Contractor's personnel employed solely on the Works, and the Contractor's costs of protecting and securing the Works and less advance payments received due in terms of the contract and less taxes due to be deducted at source as per applicable law.

- 61 Property**
- 61.1 All materials on the Site, Plant, Equipment, Temporary Works and Works are Deemed to be the property of the Employer, if the Contract is terminated because of a Contractor's default.
- 62. Release from Performance**
- 62.1 If the Contract is frustrated by the outbreak of war or by any other event entirely outside the control of either the Employer or the Contractor the Engineer shall certify that the Contract has been frustrated. The Contractor shall make the Site safe and stop work as quickly as possible after receiving this certificate and shall be paid for all work carried out before receiving it and for any work carried out afterwards to which commitment was made.

F. SPECIAL CONDITIONS OF CONTRACT

1. LABOUR

The Contractor shall, unless otherwise provided in the Contract, make his own arrangements for the engagement of all staff and labour, local or other, and for their payment, housing, feeding and transport.

The Contractor shall, if required by the Engineer, deliver to the Engineer a return in detail, in such form and at such intervals as the Engineer may prescribe, showing the staff and the numbers of the several classes of labour from time to time employed by the Contractor on the Site and such other information as the Engineer may require.

2. COMPLIANCE WITH LABOUR REGULATIONS

During continuance of the contract, the Contractor and his sub-contractors shall abide at all times by all existing labour enactments and rules made there under, regulations, notifications and bye laws of the State or Central Government or local authority and any other labour law (including rules), regulations, bye laws that may be passed or notification that may be issued under any labour law in future either by the State or the Central Government or the local authority. Salient features of some of the major laws that are applicable to construction industry are given below. The Contractor shall keep the Employer indemnified in case any action is taken against the Employer by the competent authority on account of contravention of any of the provisions of any Act or rules made there under, regulations or notifications including amendments. If the Employer is caused to pay or reimburse, such amounts as may be necessary to cause or observe, or for non-observance of the provisions stipulated in the notifications/byelaws/Acts/Rules/regulations including amendments, if any, on the part of the Contractor, the Engineer/Employer shall have the right to deduct any money due to the Contractor including his amount of performance security. The Employer/Engineer shall also have right to recover from the Contractor any sum required or estimated to be required for making good the loss or damage suffered by the Employer.

The employees of the Contractor and the Sub-Contractor in no case shall be treated as the employees of the Employer at any point of time.

SALIENT FEATURES OF SOME MAJOR LABOUR LAWS APPLICABLE TO ESTABLISHMENTS ENGAGED IN BUILDING AND OTHER CONSTRUCTION WORK

- a) **Workmen Compensation Act, 1923:** -The Act provides for compensation in case of injury by accident arising out of and during the course of employment.
- b) **Payment of Gratuity Act, 1972 :-** Gratuity is payable to an employee under the Act on satisfaction of certain conditions on separation if an employee has completed 5 years days wages for every completed service or more on death, the rate of 15 years of service. The Act is applicable to all establishments employing 10 or more employees.
- c) **Employees P.F. and Miscellaneous Provision Act 1952:** The Act Provides for monthly contributions by the employer plus workers @ 10% or 8.33%. The benefits payable under the Act are :
 - i. Pension or family pension on retirement or death, as the case may be.
 - ii. Deposit linked insurance on the death in harness of the worker,
 - iii. Payment of P.F. accumulation on retirement/death etc.
- d) **Maternity Benefit Act 1951:-** The Act provides for leave and some other benefits to women employees in case of confinement or miscarriage etc.
- e) **Contract Labour (Regulation & Abolition) Act, 1970:-** The Act provides for certain welfare measures to be provided by the Contractor to contract labour and in case the Contractor fails to provide, the same are required to be provided, by the Principal Employer by Law. The Principal Employer is required to take Certificate of Registration and the Contractor is required to take license from the designated Officer.

The Act is applicable to the establishments or Contractor of Employer, if they employ 20 or more contract labour.
- f) **Minimum Wages Act 1948 :-** The Employer is supposed to pay not less than fixed by appropriate Government as per the Minimum Wages provisions of the Act, if the employment is a scheduled employment. Construction of Buildings, Roads, Runways are scheduled employments.
- g) **Payment of Wages Act 1936:-** It lays down as to by what date The wages be paid and what deductions can are to be paid, when it will be made from the wages of the workers.
- h) **Equal Remuneration Act 1979:-** The Act provides for payment of equal wages for work of equal nature to Male and Female workers and for not making discrimination against Female employees in the matters of transfers, training and promotions etc.
- i) **Payment of Bonus Act 1965:** - The Act is applicable to all establishments employing 20 or more employees. The Act provides for payments of annual bonus subject to a minimum of 8.33% of wages and maximum of 20% of wages to employees drawing Rs.3500/-per month or less. The bonus to be paid to employees getting Rs.2500/- per month or above upto Rs.3500/- per month shall be worked out by taking wages as Rs.2500/ -per month only. The Act does not apply to certain establishments. The newly set-up establishments are exempted

for five years in certain circumstances. Some of the State Governments have reduced the employment size from 20 to 10 for the purpose of applicability of this Act.

- j) **Industrial Disputes Act 1947:-** The Act lays down the machinery and procedure for resolution of Industrial disputes, in what situations a strike or lock-out becomes illegal and what are the requirements for laying off or retrenching the employees or closing down the establishment.
- k) **Industrial Employment (Standing Orders) Act, 1946:-** It is applicable to all establishments employing 100 or more workmen (employment size reduced by some of the States and Central Government to 50). The Act provides for laying down rules governing the conditions of employment by the Employer on matters provided in the Act and get the same certified by the designated Authority.
- l) **Trade Unions Act 1926:-** The Act lays down the procedure for registration of trade unions of workmen and employers. The Trade Unions registered under the Act have been given certain immunities from civil and criminal liabilities.
- m) **Child Labour (Prohibition & Regulation) Act, 1986:-** The Act prohibits employment of children below 14 years of age in certain occupations and processes and provides for regulation of employment of children in all other occupations and processes. Employment of Child Labour is prohibited in Building and Construction Industry.
- n) **Inter-State Migrant workmen's (Regulation of Employment & Conditions of Service) Act 1979:-** The Act is applicable to an establishment which employs 5 or more inter-state migrant workmen through an intermediary (who has recruited workmen in one state for employment in the establishment situated in another state). The Inter-State migrant workmen, in an establishment to which this Act becomes applicable, are required to be provided certain facilities such as housing, medical aid, traveling expenses from home upto the establishment and back, etc.
- o) **The Building and Other Construction workers (Regulation of Employment and Conditions of Service) Act 1996 and the Cess Act of 1996:-** All the establishments who carry on any building or other construction work and employs 10 or more workers are covered under this Act. All such establishments are required to pay cess at the rate not exceeding 2% of the cost of construction as may be modified by the Government. The Employer of the establishment is required to provide safety measures at the Building or construction work and other welfare measures, such as Canteens, First-Aid facilities, Ambulance, Housing accommodations for workers near the work place etc. The Employer to whom the Act applies has to obtain a registration certificate from the Registering Officer appointed by the Government.
- p) **Factories Act 1948 :-** The Act lays down the procedure for approval of plans before setting up a factory, health and safety provisions, welfare provisions, working hours, annual earned leave and rendering information regarding accidents or dangerous occurrences to designated authorities. It is applicable to premises employing 10 persons or more with aid of power or 20 or more persons without the aid of power engaged in manufacturing process.
- q) All payments will be made subject to guidelines issued by State Government/Central Government from time to time.

- r) **Arbitration:-** Any dispute between Government and agency regarding works or any matter initially resolved by the adjudicator, if within 30 days adjudicator did not resolved the issue the matter will be finally goes to arbitration.

The Arbitration shall be conducted in accordance with the provision of the Arbitration and Conciliation Act 1996 or any Statutory modification or re-enactment thereof and the rules made there under and for the time being in force shall apply to the Arbitration.

Items marked "N/A" do not apply in this contract

SECTION 4

CONTRACT DATA

Clause Reference with respect to Section 3

1. The Employee is [CI-1.1]
Name : **Secretary, Jharkhand Industrial area Development Authority (JIADA).**
Address: **3rd Floor, JIADA New Building Namkum Ranchi.**
2. Name of Employer’s Representative – **Secretary , JIADA, Ranchi**
 3. Name of Authorized Representative: **SECRETARY JIADA, Ranchi.**
4. The Defects Liability Period is 3 Years from the date of completion. [Cl. 1.1&35]
5. The Start Date shall be 10 days for the date of issue of the Notice to proceed with the work. [Cl.1.1]
6. The Intended Completion Date for the whole of the Works is 12 months [Cl. 1.17&28] after start of work with the following milestones:

Milestone dates: [C1.2.2&49.1]
Physical works to be completed **12 Months** Period from the start date

S. No.	Milestones		Amount to be withheld in case of non achievement of milestone
	Financial Progress	Time Allowed (From date of start)	
1	1/8th (Of the whole work)	1/4 th (Of the whole work)	In the event of not achieving the necessary progress as assessed from the running payments, 1% of the tendered value of work will be withheld for failure of each milestone.
2	3/8th (Of the whole work)	1/2 th (Of the whole work)	
3	3/4th (Of the whole work)	3/4 th (Of the whole work)	
4	Full	Full	

7. The Site is located at **Construction of Basic Infrastructures (Such as Roads, Drain, Utility duct, Street Light etc.) of international Level for Hazaribagh industrial Area JIADA.** [Cl. 1.1] .
 8. The name and identification number of the Contract is: **JIADA/SBD/03/Hazaribagh/2024-25** [Cl. 1.1]
- Construction of Basic Infrastructures (Such as Roads, Drain, Utility duct, Street Light etc. for Hazaribagh industrial Area JIADA.** [Cl. 1.1]

Clause Reference with respect to section 3

(A) Road Development Works

Site clearance; setting-out and layout; widening of existing carriageway and strengthening including camber corrections: Construction of new road/ parallel/ service road; bituminous pavements remodeling construction of junctions, intersections, bus bays, lay byes; supplying and placing of drainage channels, flurries, guard posts and guard other related items; construction / extension of cross drainage works, bridges, approaches and other related stones; road markings, road signs and kilometer/ hectometer stones; protective works for roads/ bridges; all aspects of quality assurance of various components of the works; rectification of the defects in the completed works during the Defects Liability Period; submission of "As- built" drawings and any other related documents; and other item of work as may be required to be carried out for completing the works in accordance with the drawings and provisions of the contract to ensure safety.

(B) Bridge Works

Site clearance; setting out, provision of foundations, piers abutments and bearings; pre-stressed/reinforced cement concrete superstructure; wearing coat, hand railings, expansion joints, approach slabs, drainage spouts/ down take pipes, arrangements for fixing light posts, water mains, utilities etc; provision of suitable designed protective works; providing wing/return walls; provision of road markings, road signs etc. all aspects of quality assurance; clearing the site and handling over the works on completion; rectification of the defects during the Defects Liability Period; submission of "As- built" drawings and any other related documents; and other item of work as may be required to be carried out for completing the works in accordance with the drawings and provisions of the contract to ensure safety.

(C) Other Items

GSB, WMM, DBM, BC, DLC/PQC, thermoplastic road marking, road signage, earth work, PCC, Sub grade, Culverts etc.

Any other items as required to fulfill all contractual obligations as per the Bid documents. [Cl. 1.1]

10. The following documents also form part of the Contract: [Cl. 2.3(9)]
11. The law which applies to the Contract is the law of Union of India [Cl. 3.1]
12. The language of the Contract documents is English [Cl. 3.1]
13. Limit of subcontracting 50% of the Initial Contract Price [Cl. 7.1]
14. The Schedule of Other Contractors [Cl. 8]
15. The Schedule of Key Personnel As per Annex.-II to Section I [Cl.9]

16. The minimum insurance cover for physical property, injury and death [Cl.13]
is for the contract price valid till Defect Liability Period of the Project.
17. Site investigation report. [Cl.14]
18. The Site Possession Dates shall be [Cl.21]
19. Deleted
20. Deleted
21. The period for submission of the programme for approval of
Engineer shall be 21 days from the issue of Letter of Acceptance. [Cl.27.1]
22. The period between programme updates shall be 60 days. [Cl.27.3]
23. The amount to be withheld for late submission of an updated [Cl. 27.3]
programme shall be Rs. **10% of delayed work by contractor (Remaining Work)**
24. Deleted
25. The currency of the Contract is Indian Rupees. [Cl. 46]

Clause Reference with respect to section 3

26. The formula (e) for adjustment of prices are: **Deleted** [Cl. 47]

R = Value of work as defined in Clause 47.1 of Conditions of

Contract **Adjustment for cement component**

(i) Price adjustment for increase or decrease in the cost of cement procured by the contractor shall be paid in accordance with the following formula:

$$V_c = 0.85 \times P_c / 100 \times R \times (C_i - C_0) / C_0$$

V_c = increase or decrease in the cost of work during the month under consideration due to changes in rates for cement.

C_0 = The all India wholesale price index for cement on 28 days preceding the date of opening of Bids as published by the Ministry of Industrial Development, Government of India, New Delhi.

C_i = The all India average wholesale price index for cement for the month under consideration as published by Ministry of Industrial Development, Government of India, New Delhi

P_c = Percentage of cement component of the work

Adjustment for steel component

(ii) Price adjustment for increase or decrease in the cost of steel procured by the Contractor shall be paid in accordance with the following formula:

$$V_s = 0.85 \times P_s / 100 \times R \times (S_i - S_0) / S_0$$

V_s = Increase or decrease in the cost of work during the month under consideration due to changes in the rates for steel

S_0 = The all India wholesale price index for steel (Bars and Rods) on 28 days preceding the date of opening of Bids as published by the Ministry of Industrial Development, Government of India, New Delhi.

S_i = The all India average wholesale price index for steel (Bars and Rods) for the month under consideration as published by Ministry of Industrial Development, New Delhi

P_s = Percentage of steel component of the work

Note : For the application of this clause, index of Bars and Rods has been chosen to represent steel group.

Clause Reference with respect to section 3
[C1.51&52]

Adjustment of labour component

(iii) Price adjustment for increase or decrease in the cost due to labour shall be paid in accordance with the following formula:

$$V_l = 0.85 \times P_l / 100 \times R_x (L_i - L_o) / L_o$$

V_l = Increase or decrease in the cost of work during the month under consideration due to changes in rates for local labour.

L_o = The consumer price index for industrial workers for the state on 28 days preceding the date of opening of Bids, as published by labour bureau, Ministry of Labour, Government of India.

L_i = The consumer price index for industrial workers for the state under consideration as published by labour bureau, Ministry of Labour, Government of India.

L_m = Percentage of labour component of the work.

Adjustment of Other materials Component

(iv) Price adjustment for increase or decrease in cost of local materials other than cement, steel, bitumen and POL procured by the contractor shall be paid in accordance with the following formula:

$$V_m = 0.85 \times P_m / 100 \times R_x (M_i - M_o) / M_o$$

V_m = Increase or decrease in the cost of work during the month under consideration due to changes in rates for local materials other than cement, steel, bitumen and POL.

M_o = The all India wholesale price index (all commodities) on 28 days preceding the date of opening of Bids, as published by the Ministry of Industrial Development, Government of India, New Delhi. M_i = The all India wholesale price index (all commodities) for the month under consideration as published by Ministry of Industrial Development, Government of India, New Delhi.

P_m = Percentage of local material component (other than cement, steel, bitumen and POL) of the work.

Clause reference with respect to Section 3

The following percentages will govern the price adjustment for the entire contract

1. Cement – Pc	10%
2. Steel - Ps	15%
3. Other Materials – Pm	40%
4. Labour- P1	35%
Total =	100%

27. The proportion of payments retained (retention money) shall be 9% from each bill subject to a maximum of 8% of final contract price. [Cl. 48]

28	Amount of liquidated damages for delay in completion of works	<p><u>For Whole of work</u> _____ [C1.49] (1/2000)th of the Initial Contract Price, rounded off to the nearest Thousand, per day.</p> <p><u>For sectional completion (wherever specified, in item 5 of Contract Data)</u>(1/200)th of initial contract price, rounded off to the nearest thousand per day.</p>
29	Maximum limit of liquidated damages for delay in completion of work.	10 percent initial of Contract Price rounded nearest thousand. [Cl. 49]
30	Amount of Bonus for early completion of whole of the works- Deleted	1 per cent of the Initial Contract Price (part of a month to be excluded), rounded off to the nearest thousand, per month. [C1 50
31	Maximum limit of bonus for early completion of work- Deleted	6 per cent of the Contract Price rounded off to the nearest thousand. [C1 50

**Clause reference with respect to
Section 3 [C1.51&52]**

**Amount (Rs.) Conditions to be
fulfilled**

32. The amounts of the advance payment are:

Nature of Advance

i. Mobilization 10% of the Contract price

ii. Equipment 90% for new and 50% of depreciated value for old equipment. Total amount will be subject to a maximum of 5% of the Contract price.

On submission of un-conditional Bank Guarantee, (to be drawn before the end of 20% of Contract period). The contractor may furnish four bank guarantees of 2.5% each, valid for full period.

After equipment is brought to site (provided the Engineer is satisfied that the equipment is required for performance of the contract) and on Submission of unconditional Bank Guarantee for amount of advance.

33. Repayment of advance payment for mobilization and equipment: [Cl. 51.3]
The advance loan shall be repaid with percentage deductions from the interim payments certified by the Engineer under the Contract. Deductions shall commence in the next Interim payments certificate following that in which the total of all such payments to the Contractor has reached not less than 20 percent of the Contract Price or 6 (Six) months from the date of payment of first installment of advance, whichever period concludes earlier, and shall be made at the rate of 20 percent of the amounts of all Interim Payment Certificates until such time as the loan has been repaid, always provided that the loan shall be completely repaid prior to the expiry of the original time for completion pursuant to Clauses 17 and 28 (COC).

34. Deleted.

The Securities shall be for the following minimum amounts equivalent as a percentage of
35. the Contract Price : [Cl. 52]

Performance Security for 2 per cent of contract price plus **Rs.** (to be decided after evaluation of the bid) as additional security in terms of ITB Clause 29.5.

Clause reference with respect to Section 3

The standard form of Performance Security acceptable to the Employer shall be an unconditional Bank Guarantee of the type as presented in Section 8 of the Bidding Documents.

36. The Schedule of Operating and Maintenance Manuals _____ N/A [Cl. 58]
37. The date by which "as-built" drawings (in scale as directed) in 2 sets are required is within 28 days of issue of certificate of completion of whole or section of the work, as the case may be. [Cl. 58]
38. The amount to be withheld for failing to supply "as built" drawings by the date required is **Rs. 10.00 Lakh.....** [Cl. 58]
39. The following events shall also be fundamental breach of contract: [Cl. 59.2]
"The Contractor has contravened Sub-clause 7.1 and Clause 9 of GCC."
40. The percentage to apply to the value of the work not completed representing the Employer's additional cost for completing the Works shall be 20 per cent. [Cl. 60]

SECTION 5
TECHNICAL SPECIFICATION

(A) All works shall be carried out as per relevant clauses of MORT & H Specification for Roads & Bridges (5th Revision), Ref: IS code:- SP:13-2004, IRC: SP: 42-2014 and IRC : SP: 1

ARTICLE 1

GENERAL ASPECTS

1.1. **General** : Frequency of culverts and small bridges varies depending upon the region and terrain. The location, size and other details of such structures should be decided judiciously to cater for the discharge and balancing requirements. Number of culverts in 1 km length of road in India varies from one (flat country) to three in undulating regions whereas one small bridge (upto 30 m) is found within 1 to 4 km length of the road. Number of culverts may increase in hilly/undulating terrain.

1.2. Definitions

1.2.1. **Bridges** : Bridge is a structure having a total length above 6 m between the inner faces of the dirt walls for carrying traffic or other moving loads over a depression or obstruction such as channel, road or railway.

1.2.2. **Minor Bridge** : A minor bridge is a bridge having a total length of upto 60 m.

1.2.3. **Small Bridge** : A small bridge is a bridge where the overall length of the bridge between the inner faces of dirt walls is upto 30 m and where individual span is not more than 10 m.

1.2.4. **Culvert** : Culvert is a cross-drainage structure having a total length of 6 m or less between the inner faces of the dirt walls or extreme ventway boundaries measured at right angles thereto.

1.2.5. The Small Bridges and Culverts can be of following types:

- a) RCC Hume Pipes
- b) RCC slab on masonry/concrete abutment and piers
- c) Stone slab on masonry/concrete abutment and piers
- d) RCC box cell structure
- e) RCC/masonry arches on masonry/concrete abutment and piers

Stone slabs can be used upto 2 m span when good quality stones with 200 mm thickness are available.

1.3. Standard Designs

1.3.1. **MORT&H standard design for slab bridges** : Ministry of Road Transport & Highways (MORT&H) in standard design of slab bridges have proposed round figures for design span (c/c of supports). With a view to avoid confusion, same nomenclature of span is considered for culverts and small bridges. The design span of 6 m will have clear span of 5.60 m. The values of clear span, effective span and end to end of deck for which standard designs of slab bridges are available in Table 1.1.

Similarly type plans of MORT&H are available for skew slab bridges for right effective spans of 4 m, 6 m, 8 m and 10 m for skew angles of 15°, 22.5°, 30° and 35°.

Table 1.1

Clear Span m	Effective Span m	End to End of Deck m
2.6	3	3.4
3.6	4	4.4
4.6	5	5.4
5.6	6	6.4
6.6	7	7.4
7.6	8	8.4
8.6	9	9.4
9.6	10	10.4

All these RCC spans will have tar paper bearings. The type plans of MORT&H are available at the above interval and if the design span does not exactly match with the available type design, the details of next higher span length be used.

1.3.2. **H.P. culverts** : Drawings of RCC pipe culverts are available for 1000 mm diameter and 1200 mm diameter of type NP3/NP4 conforming to IS:458. PSC pipes of NP4 type conforming to IS:784 may also be used for H.P. culverts.

1.3.3. **RCC boxes** : Following RCC box section standard design of MORT&H are available with or without earth cushion.

(a) **Single Cell :**

Culvert : 2m x 2m, 5m x 3m, 5m x 4m, 5m x 5m, 2m x 3m, 3m x 3m, 4m x 3m, 4m x 4m, 4m x 5m

Small bridges : 6m x 3m, 6m x 4m, 6m x 5m, 6m x 6m, 7m x 5m, 7m x 6m, 7m x 7m, 8m x 5m, 8m x 6m, 8m x 7m

(b) **Double Cell :**

Culvert : 2m x 2m, 2m x 3m

Small bridges : 3m x 2m, 3m x 3m

(c) **Triple Cell :**

Small bridges : 2m x 2m, 3m x 3m

These are designed for varying bearing capacity of foundation stratum upto 20t/m². If the section at site does not exactly match with the available type design, details of higher section may be adopted.

Details of segmental masonry arch bridges without footpath for span 6 m and 9 m are available at **Plate 6** of this document.

1.4. **Length Related to Catchment Area** : It is generally found that when catchment area is upto 1 sq. km a culvert is required and for catchment area more than 1 sq. km a small bridge will be necessary.

ARTICLE 2

SITE INSPECTION

2.1. **Selection of Site :** Normally selection of site for culverts and small bridges is guided by road alignment. However where there is choice, select a site:

- (i) which is situated on a straight reach of stream, sufficiently down stream of bends;
- (ii) which is sufficiently away from the confluence of large tributaries as to be beyond their disturbing influence;
- (iii) which has well defined banks;
- (iv) which make approach roads feasible on the straight; and
- (v) which offers a square crossing.

2.2. **Existing Drainage Structures :** If, there is an existing road or railway bridge or culvert over the same stream and not very far away from the selected site, the best means of ascertaining the maximum discharge is to calculate it from data collected by personal inspection of the existing structure. Intelligent inspection and local inquiry will provide very useful information, namely, marks indicating the maximum flood level, the afflux, the tendency to scour, the probable maximum discharge, the likelihood of collection of brushwood during floods, and many other particulars. It should be seen whether the existing structure is too large or too small or whether it has other defects. All these should be carefully recorded.

2.3. Inspection should also include taking notes on channel conditions from which the silt factor and the co-efficient of rugosity can be estimated.

ARTICLE 3

ESSENTIAL DESIGN DATA

3.1. In addition to the information obtained by personal inspection of an existing structure, the design data described in the following paragraphs have to be collected. What is specified here is sufficient only for small bridges and culverts. For larger structures, detailed instructions contained in the Standard Specifications & Code of Practice for Bridges – Section I, of IRC:5 Clauses 100–102, should be followed.

3.2. **Catchment Area :** When the catchment, as seen from the “topo” (G.T.) sheet, is less than 1.25 sq. km in area, a traverse should be made along the watershed. Larger catchments can be read from the 1 cm = 500 m topo maps of the Survey of India by marking the watershed in pencil and reading the included area by placing a piece of transparent square paper over it.

3.3. **Cross-sections :** For a sizable stream, at least three cross-sections should be taken, namely, one at the selected site, one upstream and another downstream of the site, all to the horizontal scale of not less than 1 cm to 10 m or 1/1000 and with an exaggerated vertical scale of not less than 1 cm to 1 m or 1/100. Approximate distances, upstream and downstream of the selected site of crossing at which cross-sections should be taken are given in Table 3.1.

Table 3.1

Catchment Area	Distance (u/s and d/s of the crossing) at which cross-sections should be taken
1. Upto 3.0 sq. km	100 m
2. From 3.0 to 15 sq. km	300 m
3. Over 15 sq. km	500 m

The cross-section at the proposed site of the crossing should show level at close intervals and indicate outcrops of rocks, pools, etc. Often an existing road or a cart track crosses the stream at the site selected for the bridge. In such a case, the cross-section should not be taken along the center line of the road or the track as that will not represent the natural shape and size of the channel. The cross-section should be taken at a short distance on downstream of the selected site.

3.4. In the case of very small streams (catchments of 40 hectares or less) one cross-section may do but it should be carefully plotted so as to represent truly the normal size and shape of the channel on a straight reach.

3.5. **Highest Flood Level :** The highest flood level should be ascertained by intelligent local observation, supplemented by local enquiry, and marked on the cross-sections.

3.6. **Longitudinal Section :** The longitudinal section should extend upstream and downstream of the proposed site for the distances indicated in Table 3.1 and should show levels of the bed, the low water level and the highest flood level.

3.7. **Velocity Observation :** Attempts should be made to observe the velocity during an actual flood and, if that flood is smaller than the maximum flood, the observed velocity should be suitably increased. The velocity thus obtained is a good check on the accuracy of that calculated theoretically.

3.8. **Trial Pit Sections :** Where the rock or some firm undisturbed soil stratum is not likely to be far below the alluvial bed of the stream, a trial pit should be dug down to such rock or firm soil. But if there is no rock or undisturbed firm soil for a great depth below the stream bed level, then the trial pit may be taken down roughly 2 to 3 meter below the lowest bed level. The location of each trial pit should be shown in the cross-section of the proposed site. The trial pit section should be plotted to show the kind of soils passed through. However depth of trial pit in soils shall be minimum 2 m for culverts and 3 m for small bridges.

For more detailed investigation procedure given in Cl. 704 of IRC:78-2000 may be referred to.

3.9. For very small culverts, one trial pit is sufficient. The result should be inserted on the cross-section.

ARTICLE 4

EMPIRICAL AND RATIONAL FORMULAE FOR PEAK RUN-OFF FROM CATCHMENT

4.1. Although records of rainfall exist to some extent, actual records of floods are seldom available in such sufficiency as to enable the engineer accurately to infer the worst flood conditions for which provision should be made in designing a bridge. Therefore, recourse has to be taken to theoretical computations. In this Article some of the most popular empirical formulae are mentioned.

4.2. **Dickens Formula**

$$Q = CM^{3/4} \quad \dots(4.1)$$

Where

- Q = the peak run-off in m³/s and M is the catchment area in sq. km
 C = 11 – 14 where the annual rainfall is 60 – 120 cm
 = 14 – 19 where the annual rainfall is more than 120 cm
 = 22 in Western Ghats

4.3. **Ryve's Formula** : This formula was devised for erstwhile Madras Presidency.

$$Q = CM^{2/3} \quad \dots(4.2)$$

Where

- Q = run-off in m³/s and M is the catchment area in sq. km
 C = 6.8 for areas within 25 km of the coast
 = 8.5 for areas between 25 km and 160 km of the coast
 = 10.0 for limited areas near the hills

4.4. **Ingli's Formula** : This empirical formula was devised for erstwhile Bombay Presidency

$$Q = \frac{125M}{\sqrt{M+10}} \quad \dots (4.3)$$

Where

- Q = maximum flood discharge in m³/s
 M = the area of the catchment in sq. km

4.5. These empirical formulae involve only one factor viz. the area of the catchment and all the so many other factors that affect the run-off have to be taken care of in selecting an appropriate value of the co-efficient. This is extreme simplification of the problem and cannot be expected to yield accurate results.

4.6. A correct value of C can only be derived for a given region from an extensive analytical study of the measured flood discharges vis-à-vis catchment areas of streams in the region. Any value of C will be valid only for the region for which it has been determined in this way. Each basin has its own singularities affecting run-off. Since actual flood records are seldom available, the formulae leave much to the judgement of the engineer. Many other similar empirical formulae are in use but none of them encompasses all possible conditions of terrain and climate.

4.7. Rational Formulae for Peak-off from Catchment

4.7.1. In recent years, hydrological studies have been made and theories set forth which comprehend the effect of the characteristics of the catchment on run-off. Attempts also have been made to establish relationships between rainfall and run-off under various circumstances. Some elementary account of the rationale of these theories is given in the following paragraphs.

4.7.2. **Main factors :** The size of the flood depends on the following major factors.

Rainfall

- (1) Intensity
- (2) Distribution in time and space
- (3) Duration

Nature of Catchment

- (1) Area
- (2) Shape
- (3) Slope
- (4) Permeability of the soil and vegetable cover
- (5) Initial state of wetness

4.7.3. **Relation between the intensity and duration of a storm :** Suppose in an individual storm, F cm of rain falls in T hours, then over the whole interval of time T, the mean intensity I will be F/T cm per hour. Now, within the duration T, imagine a smaller time interval *t* (**Fig. 4.1**). Since the intensity is not uniform through-out, the mean intensity reckoned over the time interval *t* (placed suitably within T) will be higher than the mean intensity i.e. I taken over the whole period.

It is also known that the mean intensity of a storm of shorter duration can be higher than that of a prolonged one.

In other words, the intensity of a storm is some inverse function of its duration. It has been reasonably well established that

$$\frac{i}{I} = \frac{T + C}{t + c} \quad \dots(4.5a)$$

Where c is a constant

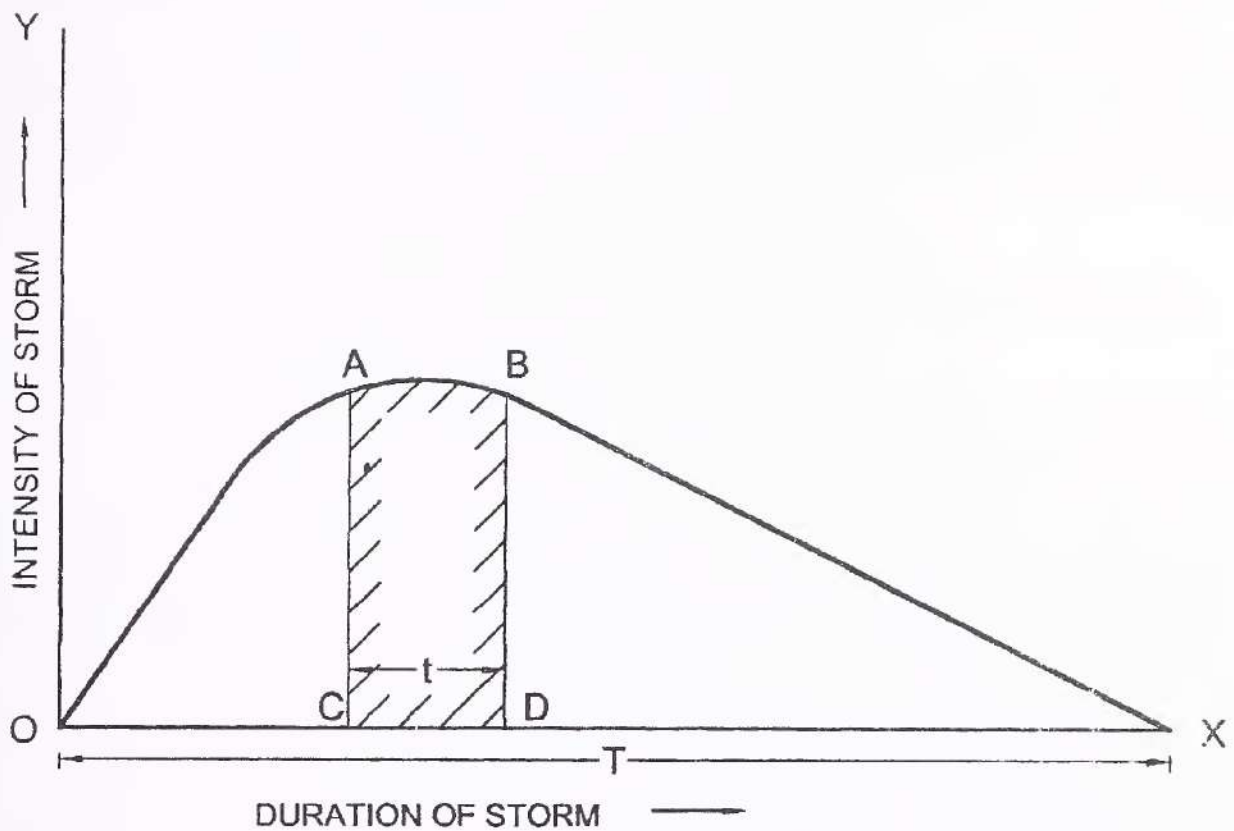

Fig. 4.1

Analysis of rainfall statistics has shown that for all but extreme cases, $c = 1$ ^{[5]*} when time is measured in hours and precipitation in cm.

Thus

$$\frac{i}{I} = \frac{T+1}{t+1} \quad \dots(4.5b)$$

$$\text{or } I = i \left(\frac{T+1}{t+1} \right) \quad \dots(4.5c)$$

Also,

$$i = \frac{F}{T} \left(\frac{T+1}{t+1} \right) \quad \dots(4.5d)$$

Thus, if the total precipitation F and duration T of a storm are known then the intensity corresponding to t , which is a time interval within the duration of the storm can be estimated.

* Refers to the number of the publication in the Bibliography.

4.7.4. For an appreciation of the physical significance of this relationship, some typical cases are considered below.

Take an intense but brief storm which drops (say) 5 cm of rain in 20 minutes. The average intensity comes to 15 cm per hour. For a short interval t of, say 6 minutes, within the duration of the storm the intensity can be as high as

$$\begin{aligned} i &= \frac{F}{T} \left(\frac{T+1}{t+1} \right) \\ &= \frac{5}{0.33} \left(\frac{0.33+1}{0.1+1} \right) = 18.2 \text{ cm per hour} \end{aligned} \quad \dots (4.6)$$

Storms of very short duration and 6 minute intensities within them (and, in general, all such high but momentary intensities of rainfall) have little significance in connection with the design of culverts except in built-up areas where the concentration time can be very short (see para 4.7.5.1) due to the rapidity of flow from pavements and roofs.

Next consider a region where storms are of medium size and duration. Suppose 15 cm of rainfalls in 3 hours. The average intensity works out to 5 cm per hour. But in time interval of one hour within the storm the intensity can be as much as

$$\frac{15}{3} \left(\frac{3+1}{1+1} \right) = 10 \text{ cm per hour} \quad \dots (4.7)$$

For the purpose of designing waterway of bridge such a storm is said to be equivalent of a "one hour rainfall of 10 cm".

Lastly, consider a very wet region of prolonged storms, where a storm drops, say, 18 cm of rain in 6 hours. In a time interval of one hour within the storm the intensity can be as high as

$$\frac{18}{6} \times \left(\frac{6+1}{1+1} \right) = 10.5 \text{ cm per hour}$$

Thus such a storm is equivalent of a "one hour storm of 10.5 cm".

4.7.5. "One-hour rainfall" for a region for designing waterway of bridges : Suppose it is decided that a bridge should be designed for peak run-off resulting from the severest storm (in the region) that occurs once in 50 years or any other specified period. Let the total precipitation of that storm be F cm and duration T hours. Consider a time interval of one hour somewhere within the duration of the storm. The precipitation in that hour could be as high as

$$\frac{F}{T} \left(\frac{T+1}{1+1} \right)$$

$$\text{or} \\ \frac{F}{2} \left(1 + \frac{1}{T} \right) \text{ cm}$$

Hence the design of the bridge will be based on a “one-hour rainfall of say I_o cm”, where

$$I_o = \frac{F}{2} \left(1 + \frac{1}{T} \right) \quad \dots (4.8)$$

Suppose **Fig. 4.1** represents the severest storm experienced in a region. If t represents one hour, then the shaded area ADBC will represent I_o .

It is convenient and common that the storm potential of a region for a given period of years should be characterised by specifying the “one-hour rainfall” I_o of the region for the purpose of designing the waterways of bridges in that region.

I_o has to be determined from F and T of the severest storm. That storm may not necessarily be the most prolonged storm. The correct procedure for finding I_o is to take a number of really heavy and prolonged storms and work out I_o from F and T of each of them. The maximum of the values of I_o thus found should be accepted as “one hour rainfall” of the region for designing bridges.

I_o of a region does not have to be found for each design problem. It is a characteristic of the whole region and applies to a pretty vast area subject to the same weather conditions. I_o of a region should be found once for all and should be known to the local engineers.

The Meteorological Department of the Government of India, have supplied the heaviest rainfall in mm/hour experienced by various places in India. This chart is enclosed as **Appendix-“A”** and the values indicated therein, may be adopted for I_o in absence of other suitable data. However, the values are upto the year 1966 and efforts are being made to obtain the current updated values.

Start with I_o and then modify it to suit the concentration time (see next para) of the catchment area in each specific case. This will now be explained.

4.7.5.1. Time of concentration (t_c): The time taken by the run-off from the farthest point on the periphery of the catchment (called the critical point) to reach the site of the culvert is called the “concentration time”. In considering the intensity of precipitation it was said that the shorter the duration considered the higher the intensity will be. Thus safety would seem to lie in designing for a high intensity corresponding to a very small interval of time. But this interval should not be shorter than the concentration time of the catchment under consideration, as otherwise the flow from distant parts of the catchment will not be able to reach the bridge in time to make its contribution in raising the peak discharge. Therefore, when examining a particular catchment, only the intensity corresponding to the duration equal to the concentration period (t_c) of the catchment, needs to be considered.

4.7.5.2. Estimating the concentration time of a catchment (t_c): The concentration time depends on (1) the distance from the critical point to the structure; and (2) the average velocity of

flow. The slope, the roughness of the drainage channel and the depth of flow govern the later. Complicated formulae exist for deriving the time of concentration from the characteristics of the catchment. For our purpose, however, the following simple relationship [11] will do.

$$t_c = \left(0.87 \times \frac{L^3}{H} \right)^{0.385} \quad \dots (4.9)$$

Where

- t_c = the concentration time in hours
 L = the distance from the critical point to the structure in km.
 H = the fall in level from the critical point to the structure in m.

L and H can be found from the survey plans of the catchment area and t_c calculated from Equation (4.9).

Plate 1 contains graphs from which t_c can be directly read for known values of L and H .

4.7.6. The critical or design intensity : The critical intensity for a catchment is that maximum intensity which can occur in a time interval equal to the concentration time t_c of the catchment during the severest storm (in the region) of a given frequency I_c . Since each catchment has its own t_c it will have its own I_c .

If we put $t = t_c$ in the basic equation (4.5d) and write I_c for the resulting intensity, we get

$$I_c = \frac{F}{T} \left(\frac{T + I}{t_c + I} \right) \quad \dots (4.10a)$$

Combining this with Equation (4.8), we get

$$I_c = I_o \left(\frac{2}{t_c + I} \right) \quad \dots (4.10b)$$

4.7.7. Calculation of run-off : A precipitation of I_c cm per hour over an area of A hectares, will give rise to a run-off

$$Q = 0.028 A I_c \text{ m}^3/\text{s}$$

To account for losses due to absorption etc. introduce a co-efficient P .

Then

$$Q = 0.028 P A I_c \quad \dots (4.11)$$

Where

- Q = max. run-off in m^3/s
 A = area of catchment in hectares
 I_c = critical intensity of rainfall in cm per hour
 P = co-efficient of run-off for the catchment characteristics

The principal factors governing P are : (i) porosity of the soil, (ii) area, shape and size of the catchment, (iii) vegetation cover, (iv) surface storage viz. existence of lakes and marshes, and (v) initial state of wetness of the soil. Catchments vary so much with regard to these characteristics that it is evidently impossible to do more than generalize on the values of P . Judgement and experience must be used in fixing P . Also see Table 4.1 for guidance.

Table 4.1 Maximum Value of P in the Formula $Q = 0.028 PAI_c$

Steep, bare rock and also city pavements	0.90
Rock, steep but wooded	0.80
Plateaus, lightly covered	0.70
Clayey soils, stiff and bare	0.60
-do- lightly covered	0.50
Loam, lightly cultivated or covered	0.40
-do- largely cultivated	0.30
Sandy soil, light growth	0.20
-do- covered, heavy brush	0.10

4.7.8. Relation between intensity and spread of storm : Rainfall recording stations are points in the space and therefore the intensities recorded there are point intensities. Imagine an area round a recording station. The intensity will be highest at the center and will gradually diminish as we go farther away from the center, till at the fringes of the area covered by the storm, intensity will be zero. The larger the area considered the smaller would be the mean intensity. It is, therefore, logical to say that the mean intensity is some inverse function of the size of the area.

If I is the maximum point intensity at the center of the storm, then the mean intensity reckoned over an area " a " is some fraction " f " of I . The fraction f depends on the area " a " and the relation is represented by the curve in Fig. 4.2 which has been constructed from statistical analysis [5].

In hydrological theories it is assumed that the spread of the storm is equal to the area of the catchment. Therefore in Fig. 4.2 the area " a " is taken to be the same as the area of the catchment. The effect of this assumption can lead to errors which, on analysis have been found to be limited to about 12 per cent [5].

4.7.9. The final run-off formula : Introducing the factor f in the Equation 4.11 we get,

$$Q = 0.028 P f A I_c \quad \dots (4.12)$$

Also combining with Equation (4.10b)

$$Q = 0.028 P f A I_o \left(\frac{2}{t_c + 1} \right) \quad \dots (4.13)$$

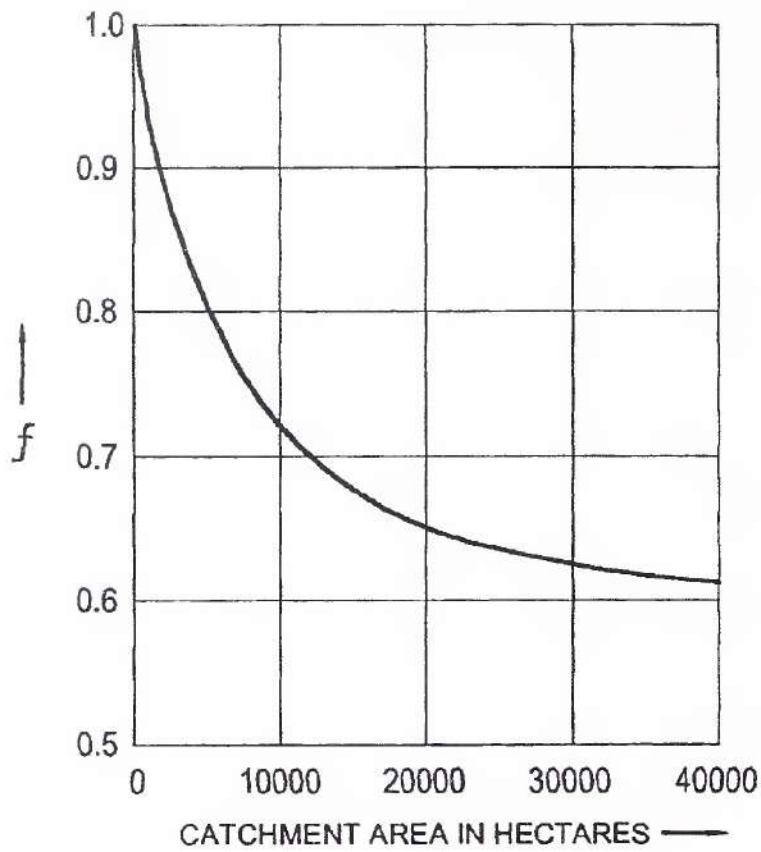

Fig. 4.2 'f' curve

$$Q = \frac{0.028 A I_0 2 f P}{t_c + 1} \quad \dots (4.14)$$

$$= A I_0 \lambda$$

Where

$$\lambda = \frac{0.056 f P}{t_c + 1} \quad \dots (4.14a)$$

In the equation 4.14(a), I_0 measures the role played by the clouds of the region and λ that of the catchment in producing the peak run-off.

It should be clear from the foregoing discussion that the components of λ are function of A, L and H of the catchment.

4.7.10. Resume of the Steps for Calculating the Run-Off

Step 1 : Note down A in hectares, L in km and H in metres from the survey maps of the area.

Step 2 : Estimate I_0 for the region, preferably from rainfall records failing that from local knowledge.

$$I_o = \frac{F}{2} \left(1 + \frac{1}{T} \right)$$

Where F is rainfall in cm dropped by the severest storm in T hours.

Step 3 : See **Plate 1** and read values of t_c , P, and f for known values of L, H and A.

Then calculate

$$\lambda = \frac{0.056 f P}{t_c + 1}$$

Step 4 : Calculate $Q = A I_o \lambda$

4.7.11. **Example :** Calculate the peak run-off for designing a bridge across a stream.

Given Catchment : L = 5 km; H = 30 metres; A = 10 sq. km = 1000 hectares. Loamy soil largely cultivated.

Rainfall : The severest storm that is known to have occurred in 20 years resulted in 15 cm of rain in 2.5 hours.

Solution :

$$I_o = \frac{F}{T} \left(\frac{T+1}{t+1} \right) = \frac{15}{2.5} \left(\frac{2.5+1}{1+1} \right) = 10.5 \text{ cm per hour}$$

From **Plate 1**, $t_c = 1.7$ hours; $f = 0.97$; $P = 0.30$

$$\lambda = \frac{0.056 f P}{t_c + 1} = \frac{0.056 \times 0.97 \times 0.30}{1.7 + 1} = 0.006$$

$$Q = A I_o \lambda = 1000 \times 10.5 \times 0.006 = 63.6 \text{ m}^3/\text{s}$$

4.7.12. **Run-off curves for small catchment areas (Plate 2) :** Suppose the catchment areas A in hectares and the average slope S of the main drainage channel are known. Assuming that the length of the catchment is 3 times its width, then both L and H [as defined in para (4.7.5.2)], can be expressed in terms of A and S and then t_c calculated from equation (4.9).

Also for small areas, f may be taken equal to one, then vide para 4.7.9.

$$Q = P I_o A \left(\frac{0.056}{t_c + 1} \right)$$

For $I_0 = 1$ cm, the equation becomes,

$$Q = PA \left(\frac{0.056}{t_c + 1} \right) \quad \dots (4.15)$$

Hence Q can be calculated for various values of P, A and S. This has been done and curves plotted in **Plate 2**.

Plate 2 can be used for small culverts with basins upto 1500 hectares or 15 sq. km. The value of run-off read from **Plate 2** are of "One Hour rainfall", I_0 , of one cm. These values have to be multiplied by the I_0 of the region. An example will illustrate the use of this Plate.

4.7.13. **Example :** The basin of a stream is loamy soil largely cultivated, and the area of the catchment is 10 sq. km. The average slope of the stream is 10 per cent. Calculate the run-off (I_0 , the one hour rainfall of the region is 2.5 cm).

Use **Plate 2**. For largely cultivated loamy soil $P = 0.3$ vide the Table in set in **Plate 2**.

Enter the diagram at $A = 10$ sq. km = 1000 hectares; move vertically up to intersect the slope line of 10 per cent. Then, move horizontally to intersect the OO line; join the intersection with $P = 0.3$ and extend to the run-off (q) scale and read.

$$q = 10.2 \text{ m}^3/\text{s}$$

Multiply with I_0 .

$$Q = 10.2 \times 2.5 = 25.5 \text{ m}^3/\text{s}$$

4.7.14. **In conclusion :** The use of empirical formulae should be done with due caution and only in consultation with expert. The average designer who cannot rely so much on his intuition and judgement should go by the rational procedure outlined above.

The data required for the rational treatment, viz., A, L and H can be easily read from the survey plans. As regards I_0 it should be realized that this does not have to be calculated for each design problem. This is the storm characteristic of the whole region, with pretty vast area, and should be known to the local engineers.

Complicated formulae, of which there is abundance, have been purposely avoided in this Article. Indeed, for a terse treatment, the factors involved are so many and their interplay so complicated that recourse need be taken to such treatment only when very important structures are involved and accurate data can be collected. For small bridges, the simple formulae given here will give sufficiently accurate results.

ARTICLE 5

ESTIMATING FLOOD DISCHARGE FROM THE CONVEYANCE FACTOR AND SLOPE OF THE STREAM

5.1. In a stream with rigid boundaries (bed and banks) the shape and the size of the cross-section is significantly the same during a flood as after its subsidence. If the HFL is plotted and the bed slope is measured, it is simple to calculate the discharge.

5.2. But a stream flowing in alluvium, will have a larger cross sectional area when in flood than that which may be surveyed and plotted after the flood has subsided. During the flood the velocity is high and, therefore, an alluvial stream scours its bed, but when the flood subsides, the velocity diminishes and the bed progressively silts up again. From this it follows that before we start estimating the flood conveying capacity of the stream from the plotted cross-section, we should ascertain the depth of scour and plot on the cross-section the average scoured bed line that is likely to prevail during the high flood.

5.3. The best thing to do is to inspect the scour holes in the vicinity of the site, look at the size and the degree of incoherence of the grains of the bed material, have an idea of the probable velocity of flow during the flood, study the trial bore section and then judge what should be taken as the probable average scoured bed line.

5.4. **Calculation of Velocity :** Plot the probable scoured bed line. Measure the cross-sectional area A in m^2 and the wetted perimeter P in m . Then calculate the hydraulic mean depth, R by the formula.

$$R = \frac{A}{P} \quad (\text{in } m) \quad \dots (5.1)$$

Next, measure the bed slope S from the plotted longitudinal section of the stream. Velocity can then be easily calculated from one of the many formulae. To mention one, viz., the Manning's formula:

$$V = \frac{I}{n} \left(R^{2/3} S^{1/2} \right) \quad \dots (5.2)$$

Where

- V = the velocity in m/s considered uniform throughout the cross-section
- R = the hydraulic mean depth
- S = the energy slope which may be taken equal to the bed slope, measured over a reasonably long reach
- n = the rugosity co-efficient

For values of n , see Table 5.1. Judgement and experience are necessary in selecting a proper value of n for a given stream.

Table 5.1 Rugosity Co-efficient, n

Surface	Perfect	Good	Fair	Bad
Natural Streams				
(1) Clean, straight bank, full stage, no rifts or deep pools	0.025	0.0275	0.03	0.033
(2) Same as (1), but some weeds and stones	0.03	0.033	0.035	0.04
(3) Winding, some pools and shoals, clean	0.035	0.04	0.045	0.05
(4) Same as (3), lower stages, more ineffective slope and sections	0.04	0.045	0.05	0.055
(5) Same as (3), some weeds and stones	0.033	0.035	0.04	0.045
(6) Same as (4), stoney sections	0.045	0.05	0.055	0.06
(7) Sluggish river reaches, rather weedy or with very deep pools	0.05	0.06	0.07	0.08
(8) Very weedy reaches	0.075	0.1	0.125	0.15

5.5. Calculation of Discharge

$$Q = A.V. \tag{5.3}$$

$$Q = \frac{A.R. S^{2/3}}{n} \tag{5.4}$$

$$Q = \lambda S^{1/2} \tag{5.5}$$

Where, $\lambda = \frac{AR^{2/3}}{n}$

λ is a function of the size, shape and roughness of the stream and is called its conveyance factor. Thus, the discharge carrying capacity of a stream depends on its conveyance factor and slope.

5.6. When the cross-section is not plotted to the natural scale (the same scale horizontally and vertically), the wetted perimeter cannot be scaled off directly from the section and has to be calculated. Divide up the wetted line into a convenient number of parts, AB, BC and CD, etc. (Fig. 5.1). Consider one such part, say PQ, let PR and QR be its horizontal and vertical projections. Then $PQ = \sqrt{PR^2 + QR^2}$. Now, PR can be measured on the horizontal scale of the given cross-section and QR on the vertical. PQ can then be calculated. Similarly, the length of each part is calculated. Their sum gives the wetted perimeter.

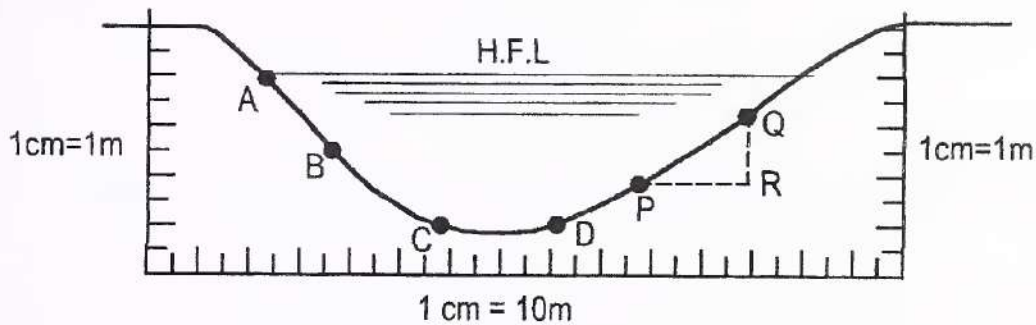

Fig. 5.1

5.7. If the shape of the cross-section is irregular as happens when a stream rises above its banks and shallow overflows are created (Fig. 5.2) it is necessary to subdivide the channel into two or three sub-sections. Then R and n are found for each sub-section and their velocities and discharges computed separately.

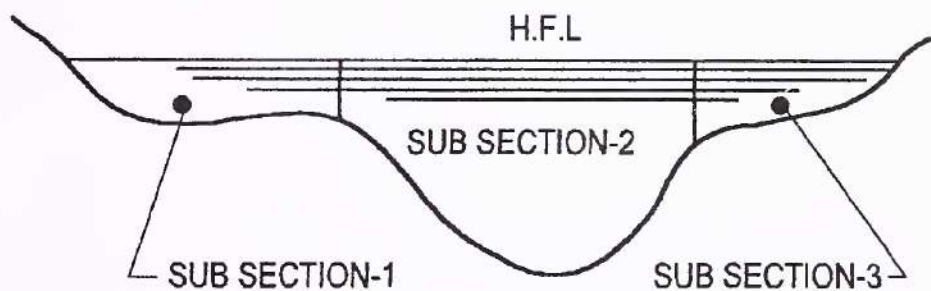

Fig. 5.2

Where further elaboration is justified, corrections for velocity distribution, change of slope, etc. may be applied. Books on Hydraulics give standard methods for this.

5.8. **Velocity Curves :** To save time in computation, curves have been plotted in Plate 3. Given R , S and n , velocity can be read from this plate.

5.9. **Better Measure than Calculate Velocity :** It is preferable to observe the velocity during a high flood. When it is not possible to wait for the occurrence of high flood, the velocity may be observed in a moderate flood and used as a check on the theoretical calculations of velocity. In making velocity observations, the selected reach should be straight, uniform and reasonably long.

5.10. The flood discharge should be calculated at each of the three cross-sections, which as already explained in para 3.3 should be plotted for all except very small structures. If the difference in the three discharges, thus, calculated is more than 10 per cent the discrepancy has to be investigated.

ARTICLE 6

DESIGN DISCHARGE

6.1. Estimated Flood Discharge from Flood Marks on an Existing Structure

6.1.1. Having collected the necessary information from inspection as mentioned in para 2.2, the discharge passed by an existing structure can be calculated by applying an appropriate formula. In Article 15 some formulae for calculating discharges from flood marks on existing bridges are discussed. Worked out examples have been included in Article 17.

6.1.2. Distinct water mark on bridge piers and other structures can be easily found immediately following the flood. Sometimes these marks can be identified years afterwards but it is advisable to survey them as soon after the flood is possible. Turbulence, standing wave and slashing may have caused a spread in the flood marks but the belt of this spread is mostly narrow and a reasonably correct profile of the surface line can be traced on the sides of piers and faces of abutments. This is perhaps the most reliable way of estimating a flood discharge because in the formulae discussed in Article-15 the co-efficient involved have been accurately found by experiments.

6.2. Fixing Design Discharge

6.2.1. **The recommended rule :** Flood discharges can be estimated in three different ways as explained in Para 4.1 to 6.1.2. The values obtained should be compared. The highest of these values should be adopted as the design discharge Q , provided it does not exceed the next highest discharge by more than 50 per cent. If it does, restrict it to that limit.

6.2.2. **Sound economy :** The designer is not expected to aim at designing a structure of such copious dimensions that it should pass a flood of any possible magnitude that can occur during the lifetime of the structure. Sound economy requires that the structure should be able to pass easily floods of a specified frequency (once in 50 years) and that extraordinary and rare floods should pass without causing excessive damage to the structure or the road.

6.2.3. The necessity for this elaborate procedure for fixing Q arises for sizeable structures. As regards small culverts, Q may be taken as the discharge determined from the run-off formulae.

ARTICLE 7

ALLUVIAL STREAMS LACEY'S EQUATIONS

7.1. The section of a stream, having rigid boundaries, is the same during the flood and after its subsidence. But this is not so in the case of streams flowing within, partially or wholly, erodible boundaries. In the latter case, a probable flood section has to be evolved from the theoretical premises for the purpose of designing a bridge; it is seldom possible to measure the cross-section during the high flood.

7.2. **Wholly Erodible Section. Lacey's Theory :** Streams flowing in alluvium are wide and shallow and meander a great deal. The surface width and the normal scoured depth of such streams have to be calculated theoretically from concepts which are not wholly rational. The theory that has gained wide popularity in India is "Lacey's Theory of Flow in Incoherent Alluvium". The salient points of that theory, relevant to the present subject, are outlined here.

7.3. A stream, whose bed and banks are composed of loose granular material, that has been deposited by the stream and can be picked-up and transported again by the current during flood, is said to flow through incoherent alluvium and may be briefly referred to as an alluvial stream. Such a stream tends to scour or silt up till it has acquired such a cross-section and (more particularly) such a slope that the resulting velocity is "non-silting and non-scouring". When this happens the stream becomes stable and tends to maintain the acquired shape and size of its cross-section and the acquired slope. It is then said : "to have come to regime" and can be regarded as stable.

7.4. **Lacey's Equation :** When an alluvial stream carrying known discharge Q has come to regime, it has a regime wetted perimeter P , a regime slope S , and regime hydraulic mean depth R . In consequence, it will have a fixed area of cross-section A and a fixed velocity V .

For these regime characteristics of an alluvial channel, Lacey suggests^[18] the following relationships. It should be noted that the only independent entities involved are Q and K_{sf} . The K_{sf} is called silt factor and its value depends on the size and looseness of the grains of the alluvium. Its value is given by the formula:

$$K_{sf} = 1.76 \sqrt{d_m} \quad \dots (7.1a)$$

where d_m is the weighted mean diameter of the particles in mm. Table 7.1 gives values of K_{sf} for different bed materials.

(Typical method of determination of weighted mean diameter of particles (d_m) as given in *Appendix-2* of IRC:5 is reproduced in **Plate 4**).

(a) Regime Cross-Section

$$P = 4.8Q^{1/2} \quad \dots (7.1b)$$

(This may vary from $4.5 Q^{1/2}$ to $6.3 Q^{1/2}$ according to local conditions)

$$R = \frac{0.473 Q^{1/3}}{K_{sf}^{1/3}} \quad \dots (7.1c)$$

$$S = \frac{0.0003 f^{5/3}}{K_{sf}^{1/6}} \quad \dots (7.1d)$$

(a) Regime Velocity and Slope

$$V = 0.44 Q^{1/6} K_{sf}^{1/3} \quad \dots (7.1e)$$

$$A = \frac{2.3 Q^{5/6}}{K_{sf}^{1/3}} \quad \dots (7.1f)$$

Table 7.1 Silt Factor K_{sf} in Lacey's Equations^[18] = $1.76 \sqrt{d_m}$

Type of bed material	d_m	K_{sf}
Coarse silt	0.04	0.35
Silt/fine sand	0.081 to 0.158	0.5 to 0.6
Medium sand	0.233 to 0.505	0.8 to 1.25
Coarse sand	0.725	1.5
Fine bajri and sand	0.988	1.75
Heavy sand	1.29 to 2.00	2.0 to 2.42

7.5. The Regime Width and Depth : Provided a stream is truly alluvial, it is destined to come to regime according to Lacey. It will then be stable and have a section and slope conforming to his equations. For wide alluvial streams the stable width W can be taken equal to the wetted perimeter P of Equation (7.1a).

That is

$$W = P = 4.8 Q^{1/2} \quad \dots (7.2a)$$

Also, the normal depth of scour D on a straight and unobstructed part of a wide stream may be taken as equal to the hydraulic mean radius R in Equation (7.1c). Hence,

$$D = \frac{0.473 Q^{1/3}}{K_{sf}^{1/3}} \quad \dots (7.2b)$$

ARTICLE 8

LINEAR WATERWAY

8.1. **The General Rule for Alluvial Streams:** The linear waterway of a bridge across a wholly alluvial stream should normally be kept equal to the width required for stability, viz., that given by Equation (7.2a).

8.2. **Unstable Meandering Streams :** A large alluvial stream, meandering over a wide belt, may have several active channels separated by land or shallow sections of nearly stagnant water. The actual (aggregate) width of such streams may be much in excess of the regime width required for stability. In bridging such a stream it is necessary to provide training works that will contract the stream. The cost of the latter, both initial and recurring, has to be taken into account in fixing the linear waterway.

8.3. In the ultimate analysis it may be found in some such cases, that it is cheaper to adopt a linear waterway for the bridge somewhat in excess of the regime width given by Equation (7.2a). But as far as possible, this should be avoided. When the adopted linear waterway exceeds the regime width it does not follow that the depth will become less than the regime depth D given by Equation (7.2b). Hence, such an increase in the length of the bridge does not lead to any countervailing saving in the depth of foundations. On the contrary, an excessive linear waterway can be detrimental in so far as it increases the action against the training works.

8.4. **Contraction to be Avoided :** The linear waterway of the bridge across an alluvial stream should not be less than the regime width of the stream. Any design that envisages contraction of the stream beyond the regime width, necessarily has to provide for much deeper foundation. Much of the saving in cost expected from decreasing the length of the bridge may be eaten up by the concomitant increase in the depth of the substructure and the size of training works. Hence, except where the section of the stream is rigid, it is generally troublesome and also futile from economy consideration to attempt contracting the waterway.

8.5. **Streams not Wholly Alluvial :** When the banks of a stream are high, well defined, and rigid (rocky or some other natural hard soil that cannot be affected by the prevailing current) but the bed is alluvial, the linear waterway of the bridge should be made equal to the actual surface width of the stream, measured from edge to edge of water along the HFL on the plotted cross-section. Such streams are later referred to as quasi-alluvial.

8.6. **Streams with Rigid Boundaries :** In wholly rigid streams the rule of para 8.5 applies, but some reduction in the linear waterway may, across some streams with moderate velocities, be possible and may be resorted to, if in the final analysis it leads to tangible savings in the cost of the bridge.

8.7. As regards streams that overflow their banks and create very wide surface widths with shallow side sections, judgement has to be used in fixing the linear waterway of the bridge. The bridge should span the active channel and detrimental afflux avoided. See also Article 18.

ARTICLE 9

NORMAL SCOUR DEPTH OF STREAMS

9.1. Alluvial Streams

9.1.1. What is the significance of the Normal Scour Depth? If a constant discharge were passed through a straight stable reach of an alluvial stream for an indefinite time, the boundary of its cross-section should ultimately become elliptical.

This will happen when regime conditions come to exist. The depth in the middle of the stream would then be the normal scour depth.

In nature, however, the flood discharge in a stream does not have indefinite duration. For this reason the magnitude and duration of the flood discharge carried by it would govern the shape of the flood section of any natural stream. Some observers have found that curves representing the natural stream sections during sustained floods have sharper curvature in the middle than that of an ellipse. In consequence, it is believed that Lacey's normal depth is an under estimate when applied to natural streams subject to sustained floods. However, pending further research, Lacey's equations may be applied.

9.1.2. As discussed later in Article 11, the depth of foundations is fixed in relation to the maximum depth of scour, which in turn is inferred from the normal depth of scour. The normal depth of scour for alluvial streams is given by Equation (7.2b), so long as the bridge does not contract the stream beyond the regime width W given by Equation (7.2a).

9.1.3. If the linear waterway of the bridge for some special reason, is kept less than the regime width of the stream, then the normal scour depth under the bridge will be greater than the regime depth of the stream (Fig. 9.1).

Where

W = the regime width of the stream

L = the designed waterway; when the bridge is assumed to cause contraction L is less than W

D = The normal scour depth when $L = W$

D' = The normal scour depth under the bridge with L less than W

According to Clause 703 of IRC:78-2000.

$$d_{sm} = 1.34 \left(\frac{D_b^2}{k_{sf}} \right)^{1/3} \quad (9.1)$$

Where

D_b = discharge in m^3/s per m width

k_{sf} = silt factor for material obtained upto deepest anticipated scour.

= $1.76 \sqrt{d_m}$, d_m being the weighted mean diameter of particles in mm.

d_{sm} = normal scour depth in m.

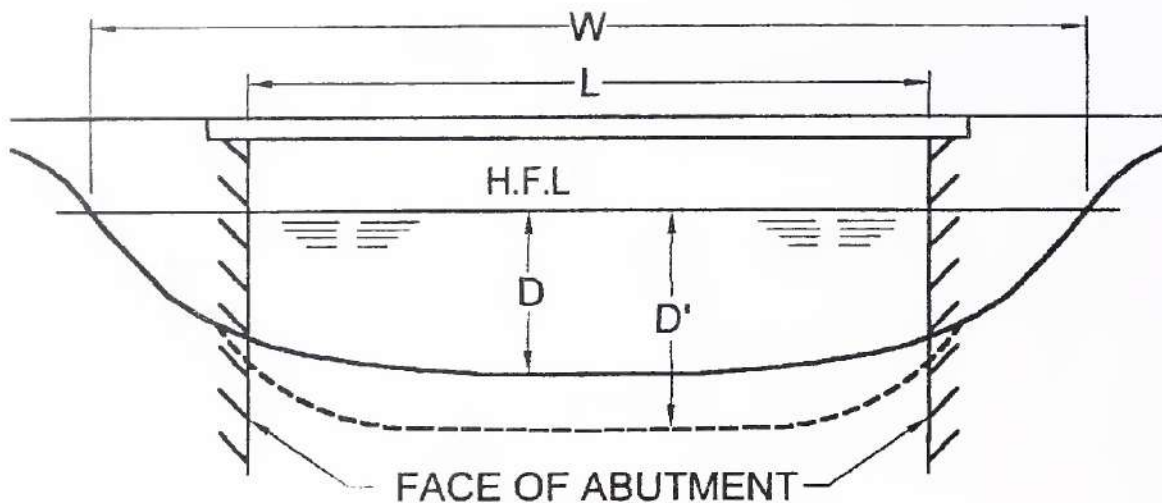

Fig. 9.1

The value of D_b shall be total design discharge divided by the effective linear waterway between abutments or guide bunds.

This formulae take into account the effect of contraction and, therefore, no further modification are needed. When the bed is protected by apron and curtain wall, the scour considerations will be different as discussed in Article-20.

9.2. Quasi-Alluvial Streams

9.2.1. **Some streams are not wholly alluvial :** A stream may flow between banks which are rigid in so far as they successfully resist erosion, but its bed may be composed of loose granular material which the current can pick-up and transport. Such a stream may be called quasi-alluvial to distinguish it, on the one hand, from a stream with wholly rigid boundaries and, on the other, from a wholly alluvial stream. Since such a stream is not free to erode its banks and flatten out the boundaries of its cross-section as a wholly alluvial stream does, it does not acquire the regime cross-section which Lacey's equations prescribe.

9.2.2. It is not essential that the banks should be of rock to be inerodible. Natural mixtures of sand and clay may, under the influence of elements, produce material hard enough to defy erosion by the prevailing velocity in the stream.

Across a stream section, the natural width of which is nowhere near that prescribed by Lacey's theory, it is expected to find that the banks, even though not rocky are not friable enough to be treated as incoherent alluvium for the application of Lacey's Theory. Such cases have, therefore, got to be discriminated from the wholly alluvial streams and treated on a different footing.

9.2.3. In any such case the width W of the section, being fixed between the rigid banks, can be measured. But the normal scour depth D corresponding to the design discharge Q has to be estimated theoretically as it cannot be measured during the occurrence of high flood.

9.2.4. **When the stream width is large compared to depth :** In Article-5, for calculating the discharge of the stream from its plotted cross-section, the probable scoured bed line (para 5.3) was drawn.

When the stream scours down to that line it should be capable of passing the discharge calculated there, say $q \text{ m}^3/\text{s}$. But the discharge adopted for design, Q , may be anything upto 50 per cent more than q (see para 6.2.1). Therefore, the scour bed line will have to be lowered further. Suppose the normal scour depth for Q is D and that for q is d , then,

$$D = d \left(\frac{Q}{q} \right)^{3/5} \quad \dots (9.2)$$

Since d is known, D can be calculated. This relationship depends on the assumption that the width of the stream is large as compared, with its depth, and therefore, the wetted perimeter is approximately equal to the width and is not materially affected by variations in depth. It also assumes that the slope remains unaltered.

$$\begin{aligned} Q &= \text{area} \times \text{velocity} \\ &= R P C R^{2/3} S^{1/2} \\ &= K R^{5/3} \end{aligned} \quad \dots (9.3)$$

where K is a constant.

Hence, R varies as $Q^{3/5}$. Since in such streams R is very nearly equal to the depth, therefore, D varies as $Q^{3/5}$. Hence, the equation (9.2).

From the above relationship it follows that if Q is 150 per cent of q , D will be equal to 127 per cent of d .

9.2.5. Alternatively, the normal depth of scour of wide streams may be calculated as under. If the width of the stream is large as compared with its depth, then W may be taken as P and D as R .

$$\begin{aligned} Q &= \text{area} \times \text{velocity} \\ &= (PR) V = (WD) V, \text{ where } V \text{ is the mean velocity} \quad \dots(9.4) \\ D &= \frac{Q}{WV} \end{aligned}$$

Now W is the known fixed width of the stream. If the velocity V has actually been observed (para 5.9), then D can be calculated from the above equation. For mean velocity, refer relevant clause in IRC:6.

9.2.6. Suppose the velocity has not been actually measured during a flood, but the slope S is known.

$$\begin{aligned}
 Q &= \text{area} \times \text{velocity} \\
 &= \frac{(RP) R^{2/3} S^{1/2}}{n} \\
 &= \frac{WS^{1/2} D^{5/3}}{n} \quad \dots (9.5)
 \end{aligned}$$

Knowing Q , W and S , D can be calculated from this equation.

For quickness, velocity curves in **Plate 3** can be used. Assume a value of R and fix a suitable value of the rugosity co-efficient n appropriate for the stream. Corresponding to these values and the known slope, read the velocity from **Plate 3**. Now calculate the discharge (= VRW). If this equals the design discharge Q , then the assumed value of R is correct. Otherwise, assume another value of R and repeat. When the correct value of R has been found, take D equal to R . (See the worked out Example in Article-16).

9.2.7. The procedure described above can be applied if either the slope of the stream or the actual observed velocity is known. If either of these are not known, the following procedure for approximate calculation of the normal scour depth can be applied.

Suppose the wetted perimeter of the stream is P and its hydraulic mean depth R . If Q is its discharge, then,

$$\begin{aligned}
 Q &= \text{area} \times \text{velocity} \\
 &= (PR) (CR^{2/3} S^{1/2}) \quad \dots (9.6a)
 \end{aligned}$$

Now, if this stream, carrying the discharge Q , had been wholly alluvial, with a wetted perimeter P_1 and hydraulic mean depth R_1 for regime conditions, then,

$$Q = (P_1 R_1) (CR^{2/3} S^{1/2}) \quad \dots (9.6b)$$

Also, for a wholly alluvial stream Lacey's Theory would give:

$$P_1 = 4.8 Q^{1/2} \quad \dots (9.6c)$$

$$R_1 = \frac{0.473 Q^{1/3}}{K_{sf}^{1/3}} \quad \dots (9.6d)$$

Equating values of Q in (9.6a) and (9.6b), and rearranging we get

$$\frac{R}{R_1} = \left(\frac{P_1}{P} \right)^{3/5} \quad \dots (9.6e)$$

Now substituting values of P_1 and R_1 from equations (9.6c) and (9.6d) in (9.6e), we get

$$R = \frac{1.21Q^{0.63}}{K_{sf}^{0.33} p^{0.60}} \quad \dots (9.6f)$$

If the width W of the stream is large compared with its depth D , then writing W for P and D for R in equation (9.6f).

$$D = \frac{1.21Q^{0.63}}{K_{sf}^{0.33} W^{0.60}} \quad \dots (9.7)$$

Thus, if the design discharge Q , the natural width W , and the silt factor K_{sf} are known, the normal scour depth D can be calculated from Equation (9.7).

The above reasoning assumes that the slope at the section in the actual case under consideration is the same as the slope of the hypothetical (Lacey's) regime section, carrying the same discharge. This is not improbable where the stream is old and its bed material is really incoherent alluvium. But if there is any doubt about this, the actual slope must be measured and the procedure given in para 9.2.6 applied.

9.2.8. When the stream is not very wide : If the width of the stream is not very large as compared with its depth, then the methods given above will not give accurate enough results. In such a case draw the probable scoured bed line on the plotted cross-section, measure the area and the wetted perimeter and calculate R .

Corresponding to this value of R and the known values of S and n , read velocity from **Plate 3**. If the product of this velocity and the area equals the design discharge, the assumed scoured bed line is correct. Otherwise, assume another line and repeat the process. Then measure D .

9.2.9. Effect of contraction on normal scour depth : If, for some special reason, the linear waterway L of a bridge across a quasi-alluvial stream is kept less than the natural unobstructed width W of the stream (**Fig. 9.1**), then the normal scour depth under the bridge D' will be greater than the depth D ascertained above for the unobstructed stream. Covered by the relationship:

$$D' = 1.34 \left(\frac{D_b^2}{K_{sf}} \right)^{1/3} \quad \dots (9.8)$$

Because D_b of L case will be more than D_b of W case.

9.3. Scour in Clay and Bouldary Strata : There are no rational methods for assessment of scour in clay or bouldary strata. Guidelines for calculating silt factor for bed materials consisting of gravels and boulders as given in Appendix-I of IRC:78-2000 may be adopted and are reproduced in paras 9.3.1 and 9.3.2.

9.3.1. **Scour in clay** : Scour in clay is generally less than scour in sand. Normally in field we get a mixture of sand and clay at many places. For the purpose of assessment following definition of sand and clay can be given.

- Sand - Where ϕ is equal to or more than 15° even if c (Cohesion of soil) is more than 0.2 kg/cm^2
(Silt factor K_{sf} will be calculated as per provisions of para 7.4 or Table 7.1).
- Clay - Where ϕ is less than 15°
& c (Cohesion of soil) is more than 0.2 kg/cm^2

Scour in sand of above definition can be calculated by the formulae given earlier. In clay instead of silt factor (K_{sf}) clay factor (K_{sfc}) is adopted –

$$K_{sfc} = F (1 + \sqrt{c})$$

Where

- c = Cohesion in kg/cm^2 and ... (9.9)
 F = 1.5ϕ for $\phi \geq 10^\circ < 15^\circ$
 = 1.75 for $\phi \geq 5^\circ < 10^\circ$
 = 2.0 for $\phi < 5^\circ$

$$\text{Scour depth (dsm)} = 1.34 \left(D_b^2 / K_{sfc} \right)^{1/3}$$

D_b = discharge per unit width

9.3.2. **Bouldary strata** : There is no rational method to assess scour in bouldary strata of boulders or pebbles. In the absence of any formula K_{sf} may be determined as per Clause 703.2.2 of IRC:78 and adopted. If, say, average size of pebbles is d_b

$$\text{Then, } K_{sf} = 1.76 (d_b)^{1/2}$$

for $d_b = 50 \text{ mm}$

$$K_{sf} = 1.76 (50)^{1/2} = 12.4 \quad \dots (9.10)$$

$$\text{Scour depth} = 1.34 \left(\frac{D_b^2}{K_{sf}} \right)^{1/3} = 1.34 \left(\frac{D_b^2}{12.4} \right)^{1/3}$$

It is, however, better to investigate depth of foundations adopted in past for similar foundation and decide depth on the basis of precedence. Protection work around foundations in the form of curtain wall and apron or garland blocks should be provided, when the foundation is laid on bouldary strata.

ARTICLE 10

MAXIMUM SCOUR DEPTH

10.1. In considering bed scour, we are concerned with alluvial and quasi-alluvial streams only and not with streams which have rigid beds.

10.2. In natural streams, the scouring action of the current is not uniform all along the bed width. It is not so even in straight reaches. Particularly at the bends as also round obstructions to the flow, e.g., the piers of the bridge, there is deeper scour than normal. In the following paragraphs, rules for calculating the maximum scour depth are given. It will be seen that the maximum scour depth is taken as a multiple of the normal scour depth according to the circumstances of the case.

10.3. In order to estimate the maximum scour depth, it is necessary first to calculate the normal scour depth. The latter has already been discussed in detail. To summarise what has been said earlier, the normal scour depth will be calculated as under :

- (i) **Alluvial Streams.** Provided the linear waterway of the bridge is not less than the regime width of the stream, the normal scour depth D is the regime depth as calculated from Equation (7.2b).
- (ii) **Streams with Rigid Banks but Erodible Bed.** Provided the linear waterway of the bridge is not less than the natural unobstructed surface width of the stream, the normal scour depth d is calculated as explained in Article 9.

10.4. Rules for finding Maximum Scour Depth. The rules for calculating the maximum scour depth from the normal scour depth are:

- Rule (1) :** For average conditions on a straight reach of the stream and when the bridge is a single span structure, i.e. it has no piers obstructing the flow, the maximum scour depth should be taken as 1.27 times the normal scour depth, modified for the effect of contraction where necessary.
- Rule (2) :** For bad sites on curves or where diagonal current exist or the bridge is multi-span structure, the maximum scour depth should be taken as 2 times the normal scour depth, modified for the effect of contraction when necessary.

10.5. The finally adopted value of maximum scour depth must not be less than the depth (below HFL) of the deepest scour hole that may be found by inspection to exist at or near the site of the bridge.

The following example will illustrate the application of the rules in para 10.4 above.

10.6. **Example 1.** A bridge is proposed across an alluvial stream ($K_{sf} = 1.2$) carrying a discharge of $50 \text{ m}^3/\text{s}$. Calculate the depth of maximum scour when the bridge consists of (a) 3 spans of 6 m and (b) 3 spans of 8 m

Regime surface width of the stream

$$W = 4.8Q^{1/2} = 4.8 \times 50^{1/2} = 33.94 \text{ m}$$

Regime depth

$$D = 0.473 \frac{Q^{1/3}}{K_{sf}^{1/3}} = \frac{0.473 \times 50^{1/3}}{(1.2)^{1/3}} = 1.64 \text{ m}$$

Maximum scour depth

(a) when span (3x6 m), D_b the discharge per metre width is

$50/18$, i.e., 2.778 cumecs

$$d_{sm} = 1.34 (2.778^2/1.2)^{1/3} = 2.49 \text{ m}$$

(i) Maximum depth of scour for pier

$$= 2 d_{sm} = 2 \times 2.49 = 4.98 \text{ m}$$

(ii) Maximum depth of scour for abutment

$$= 1.27 d_{sm} = 1.27 \times 2.49 = 3.16 \text{ m}$$

(b) When span is 3 x 8 m, D_b the discharge per metre width is

$50/24$, i.e., 2.083 cumecs

$$d_{sm} = 1.34 (2.083^2/1.2)^{1/3} = 2.055 \text{ m}$$

(i) Maximum depth of scour for pier

$$= 2 d_{sm} = 2 \times 2.055 = 4.11 \text{ m}$$

(ii) Maximum depth of scour for abutment

$$= 1.27 d_{sm} = 1.27 \times 2.055 = 2.61 \text{ m}$$

ARTICLE 11**DEPTH OF FOUNDATIONS**

11.1. The following rules should be kept in view while fixing the depth of bridge foundations:

Rule (1) In Soil. The embedment of foundations in soil shall be based on assessment of anticipated scour. Foundations may be taken down to a comparatively shallow depth below the bed surface provided good bearing stratum is available and foundation is protected against scour. The minimum depth of open foundations shall be upto stratum having adequate bearing capacity but not less than 2.0m below the scour level or protected scour level.

Rule (2) In Rocks. When a substantial stratum of solid rock or other material not erodible at the calculated maximum velocity is encountered at a level higher than or a little below that given by Rule (1) above, the foundations shall be securely anchored into that material. This means about 0.6 m into hard rocks with an ultimate crushing strength of 10 MPa or above and 1.5 m in all other cases.

Rule (3) All Beds. The pressure on the foundation material must be well within the safe bearing capacity of the material.

These rules enable one to fix the level of the foundations of abutments and piers.

11.2. The above rules are applicable for open foundations only. For deep foundations like well, and pile foundations, wherever adopted depending upon site requirements depth of foundations shall be worked out as per IRC: 78.

ARTICLE 12

SPAN AND VERTICAL CLEARANCE

12.1. As a rule, the number of spans should be as small as possible, since piers obstruct flow. Particularly, in mountainous regions, where torrential velocities prevail, it is better to span from bank to bank using no piers if possible.

12.2. **Length of Span :** In small structures, where open foundations can be laid and solid abutments and piers raised on them, it has been analysed that the following approximate relationships give economical designs.

For Masonry arch bridges $S = 2 H$

For RCC Slab Bridges $S = 1.5 H$

Where

S = Clear span length in metres

H = Total height of abutment or pier from the bottom of its foundation to its top in metres. For arched bridges it is measured from foundation to the intrados of the key stone.

12.3. **Vertical Clearance :** After fixing the depth of foundations D_f , the vertical clearance is added to it to get H. The minimum vertical clearance shall be provided as per Table 12.1.

Table 12.1

Discharge in m ³ /s	Minimum vertical clearance in mm
Upto 0.30	150
Above 0.3 and upto 3.0	450
Above 3 and upto 30	600
Above 30 and upto 300	900
Above 300 and upto 3000	1200
Above 3000	1500

For openings of culverts having arched decking, the clearance below the crown of the intrados of arch shall not be less than 1/10 of the maximum depth of water plus 1/3 of the rise of arch intrados.

Further to keep the free board of approaches not less than 1750 mm (Clause 107.1 of IRC:5) the vertical clearance in slab/box cell bridges may be increased suitably.

In designing culverts for roads across flat regions where streams are wide and shallow (mostly undefined dips in the ground surface), and in consequence the natural velocities of flow are very low, the provision of clearance serves no purpose. Indeed it is proper to design such culverts on the assumption that the water at the inlet end will pond up and submerge the inlet to a predetermined extent. This will be discussed in Article 19.

In case of structure over artificial channels or canals, etc. the minimum vertical clearance should be taken 600 mm above the Full Supply Level.

12.4. The Number of Spans:

12.4.1. If the required linear waterway L is less than the economical span length it has to be provided in one single span.

12.4.2. When L is more than the economical span length (S) the number of spans (N) required is tentatively found from the following relation:

$$L = NS$$

12.4.3. Since N must be a whole number (preferably odd) S has to be modified suitably. In doing so it is permissible to adopt varying span lengths in one structure to keep as close as possible to the requirements of economy and to cause the least obstructions to the flow.

12.5. To facilitate inspection and carrying out repairs, the minimum vent height of culverts should normally be 1500 mm. The vent size of irrigation culverts may be decided considering the actual requirements and site condition. For pipe culverts minimum diameter should be 1000 mm.

ARTICLE 13

GEOMETRIC STANDARDS, SPECIFICATIONS AND QUALITY CONTROL

13.1. Details of small bridges and culverts of probable spans and heights conforming to latest IRC codes and guidelines are incorporated with a view to cut short the time in preparation of estimates and design of culverts and attain uniform standards and quality control in the work.

13.2. Geometric Standards

13.2.1. **IRC standards :** Standards contained in IRC:73 and IRC:86 are adopted for Geometric Standards. The overall widths adopted for culverts and small bridges for 2-lane carriageway are as follows.

NH and SH	-	12 m
MDR	-	8.4 m

Fig. 13.1 gives width for 4-lane roads.

13.2.2. **Design loads for 2-lane roadway :** Design loading for culverts and small bridges should be as below:

Village Road and ODR (Rural Roads)	-	2-lanes IRC Class A
NH, SH and MDR	-	70 R or 2-lanes of Class A whichever gives worst effect

13.2.3. **Width of roadway :** The width of a culvert and small bridge (along the direction of flow) should be such that the distance between the outer faces of the parapets will equal the full designed width of the formation of the road. Any proposed widening of the road formation in the near future should also be taken into account in fixing the width of the structure. In case of high banks, the length of culvert should be judiciously decided to avoid high face walls.

13.2.4. In small bridges, the width (parallel to the flow of the stream) should be sufficient to give a minimum clear carriageway of 4.25 m for a single-lane bridge and 7.5 m for a two-lane bridge between the inner faces of the kerbs or wheel guards. Extra provision should be made for footpaths, etc., if any are required.

13.2.5. **Siting of structures and gradients :** Culverts and small bridges must be sited on the straight alignment of roads. If the Nalla is crossing the road at angles other than right angle, either skew culverts and small bridges should be provided or, if economical, the Nalla should be suitably trained. The same gradient of road may be provided for these. If these are situated at change of gradient (hump), the profile of vertical curve should be given in wearing coat. Alternatively, the profile could be given in the deck itself. The bearing surface of deck slab on the abutmen/pier cap should be horizontal.

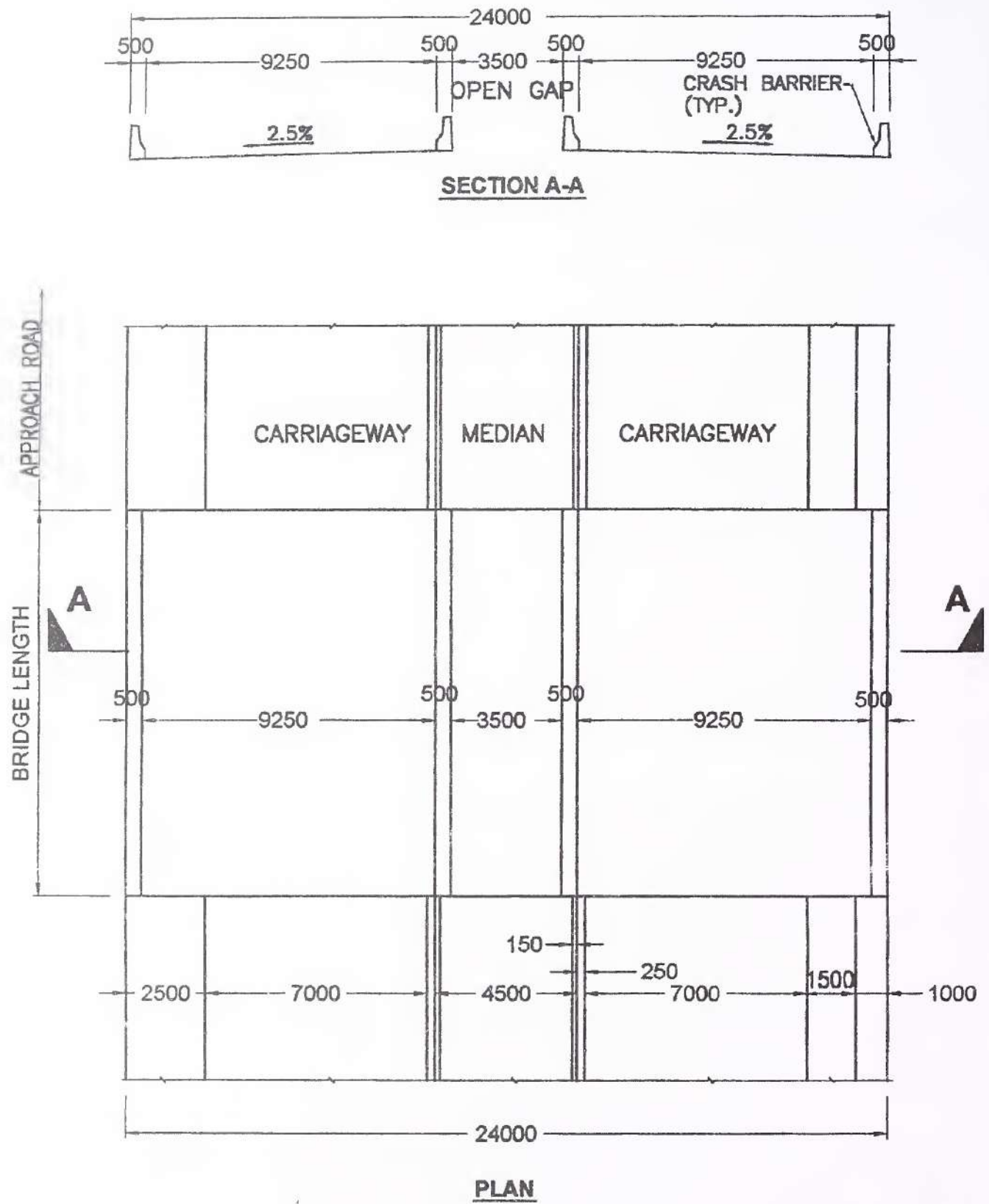

Fig. 13.1

13.3. Design :

13.3.1. **Road top level** : For maintaining the geometric standards of the road, culverts and small bridges should be constructed simultaneously with the earthwork as otherwise there would be the following two disadvantages.

- (1) Practically, every culvert and small bridge becomes a hump on the road and geometric of the road is affected.
- (2) Duplicate work of consolidation of approaches giving rise to extra cost.

13.3.2. **Minimum span and clearance** : From the consideration of maintenance of culverts, it is desirable that the span of slab culvert is kept minimum 2 m and height 1.5 m and diameter of pipes 1.0 m. Culverts of small span or diameter are found to get choked due to silting and also cause difficulty in cleaning.

13.3.3. **Pipe culverts** : Pipe culverts shall conform to IS category NP3/NP4. The cushion between the top of the pipe and the road level shall not be less than 600 mm. First class bedding consisting of compacted granular material can be used for height of fill upto 4 m and concrete cradle bedding upto a maximum height of fill upto 8 m.

For small size structures, RCC pipe culverts with single row or upto six rows of R.C.C. pipes, depending upon the discharge may be used as far as possible, as they are likely to prove comparatively cheaper than slab culverts.

13.3.4. **RCC slab** : RCC slab culverts and small bridges should be adopted where the founding strata is rocky or of better bearing capacity. In case where adequate cushion is not available for locating pipe culvert RCC slab culvert should be adopted. RCC slab culverts/bridges are also useful for cattle crossing during dry weather.

13.3.5. **RCC box cell structures** : In a situation where bearing capacity of soil is low, RCC Box type culvert should be preferred.

13.3.6. **Balancing culverts** : Balancing culvert are to be located at points on L section of the road where down gradients meet. These balancing culverts balance the discharge from either side of the road. Observation of the road alignment during rains also gives a good idea about location of balancing culverts.

13.4 Numbering of Culverts and Small Bridges :

13.4.1. The number of culvert/small bridge is indicated in each km. For instance number 21/8 represents the 8th CD structure in kilometer 21.

The information regarding (1), the number of spans (2), clear span length in m and (3) the type of decking or culverts is indicated below:

Number of spans, clear span in m, type of culvert/small bridges are given, e.g., $1 \times 2 \times S$ means 1 span of 2 m with RCC solid slab. For various types of culverts and small bridges

the suffix (3) will be represented by –

RCC Solid slab	-	S	Pipe culvert	-	P
Arch	-	A	Box Type	-	B
Stone Slab	-	ST			

13.4.2. The number of the structure shall be inscribed near the top of the left hand side parapet wall as seen by traffic in the end elevation when approaching the structure from each direction.

In situations where instead of parapet walls, the structure is provided with railings, but having no end supporting pillars on which the number could be inscribed, the number of the structure shall be indicated by means of a numbering plate of the size 300 x 300 mm. There shall be two such numbering plates, one for each direction of travel. The plates shall be welded or fixed securely to the railing on the left hand side facing the carriageway as close to the entrance to the structure as possible.

In the case of buried culverts, such as pipe culverts, where there is usually no parapet walls or railings at the roadway level, two stone or RCC posts, having a cross-section of 150x150 mm and exposed height 300 mm shall be set up, one on each side to mark the position of the culvert. Care shall be taken to locate the marker posts fully outside the prescribed roadway width. The culvert number shall not be engraved on the marker posts but be either engraved or painted at their base.

13.4.3. For details reference may be made to “Recommended Practice for Numbering Bridges and Culverts”, IRC:7-1971.

13.5. General Design Aspects and Specifications : The type design of pipe culverts and RCC slab culverts and slab bridges given here are based on following general aspects. Coursed rubble stone masonry for substructure and parapet walls is generally found to be economical in comparison to mass concrete substructure. The masonry below or above the ground level should be as per IRC:40. If bricks having minimum crushing strength of 7 Mpa are available, these can also be used for culverts.

13.5.1. Parapet wall and railing : For culverts, where parapet walls are provided they shall be of plain concrete M15 grade or brick or store masonry with 450 mm top width. In case of pipe culverts no parapet walls are needed and guard stones would be adequate except for culverts on hill roads. Guard stones provided shall be of size 200x200x600 mm. Railings as given in Standard Drawings of MORT&H may also be provided for culverts and small bridges. Railings or parapets shall have a minimum height above the adjacent roadway or footway safety kerb surface of 1.1 m less one half the horizontal width of the top rail or top of the parapet. Crash barriers may be provided when they are found functionally required. Crash barriers when provided shall conform to provisions in IRC:5 and while adopting MORT&H standard drawings, the design of deck slab shall be checked for provision of crash barriers.

13.5.2. Wearing coat : Normally, the wearing surfaces of the road shall be carried over the

culverts/small bridges. However for low category road which do not have bituminous surfaces, concrete wearing coat of average 75 mm need be adopted and approach profile may be suitably graded.

13.5.3. **Approach slab :** Approach slab can be dispensed with in case of culverts.

13.5.4. **Deck slab :** M 20 concrete for moderate and M 25 concrete for severe conditions of exposure and high strength deformed bars conforming to IS:1786 are specified for the deck slabs.

13.5.5. **Expansion joint :** For spans upto 10 m premoulded bituminous sheet (like, shalitek board) of 20 mm thickness are required to be provided.

RCC slab shall rest on tar paper over abutment/pier cap.

13.5.6. **Pier/abutment cap/coping :** The minimum thickness of reinforced cap over solid PCC/RCC substructure shall be 200 mm and that in case of masonry substructure shall not be less than 500 mm. The minimum grade of concrete shall be M 20 and M 25 for moderate and severe conditions of exposure respectively. However, the coping over the returns may be of M 15 grade and thickness not less than 100 mm.

13.5.7. **Section of pier abutment and returns :** The abutment and pier sections should be so designed as to withstand safely the worst combination of loads and forces as specified in the IRC:6-2000.

13.5.8. **Top width of pier/abutment :** In respect of masonry and concrete piers/abutments minimum width at top of pier and abutments for slab bridges just below the caps shall be as per Table 13.1. Tar paper bearings shall be provided between abutment/peir cap and RCC slab for spans upto 10 m.

Table 13.1

Span (in m)	Minimum width at top of abutment/pier (mm)
2.0	500
3.0	500
4.0	1000
5.0	1000
6.0	1200
8.0	1200
10.0	1200

If the velocity flow is more than 4.5 m/s and river carries abrasive particles, it is advisable to design section of foundation and pier considering their effect. A sacrificial layer of brick/stone masonry of suitable thickness and height shall be provided irrespective of total height of substructure.

In the case of arch bridges, the top width of abutments and piers should be adequate to accommodate skew decks and to resist the stresses imposed under the most unfavourable conditions of loading.

13.5.9. Return walls or wing walls : Wing walls are generally at 45° angle to the abutment and are also called as splayed wing walls. Walls parallel to road are called as return walls.

Where embankment height exceeds 2 m, splayed return walls may be preferred. The length of straight return should normally be 1.5 times the height of the embankment. Where the foundations of the wing walls can be stepped up, having regard to the soil profile, this should be done for the sake of economy. Quite often short return walls meet the requirements of the site and should be adopted.

The top width of wing walls and returns shall not be less than 450 mm.

13.5.10. Weepholes and water spouts : Adequate number of weepholes at spacing not exceeding 1 m in horizontal and vertical direction should be provided to prevent any accumulation of water and building up of the hydrostatic pressure behind the abutment and wing walls. The weep holes should be provided at about 150 mm above low water level or ground level whichever is higher. Weepholes shall be provided with 100 mm dia AC pipes for structures in plain/reinforced concrete, brick masonry and stone masonry. For brick and stone masonry structures, rectangular weepholes of 80 mm wide and 150 mm height may also be provided. Weepholes shall extend through the full width of the concrete/masonry with slope of about 1 vertical to 20 horizontal towards the drainage face.

In case of stone masonry, the spacing of weep holes shall be adjusted to suit the height of the course in which they are formed. The sides and bottom of the weep holes in the interior shall be made up with stones having fairly plain surface.

For spans more than 5 m one water spout of 100 mm dia. in the center of the slab located on either side of the deck shall be provided. The spacings of drainage spouts shall not exceed 10 m.

In case of one side camber the number shall be doubled and location suitably adjusted.

13.5.11. Foundation concrete : Foundation concrete shall not be less than M 15 grade. If the foundation level is below water table, 10 per cent extra cement is to be added in concrete. The minimum depth of footing shall be 300 mm. For foundation resting on rock a levelling course of at least 150 mm in M 15 grade of concrete shall be used.

13.5.12. Arches : The type of superstructure depends on the availability of the construction materials and its cost. An evaluation of the relative economics of RCC slabs and masonry arches should be made and the latter adopted where found more economical.

The masonry arches may be either of cement concrete blocks of M 15 or dressed stones or bricks in 1:3 cement mortar. The crushing strength of concrete, stone or brick units shall not be less than 105 kg/cm². Where stone masonry is adopted for the arch ring, it shall be either coursed rubble masonry or ashlar masonry.

13.5.13. **Raft foundation** : Raft foundations are found to be quite suitable for small bridges and culverts where the founding strata is soft and has SBC upto 10 t/m^2 . The following aspects are to be kept in consideration.

- (1) Raft foundations are suitable for all types of structures other than pipe culverts.
- (2) Protection needs to be provided in the form of apron.
- (3) Cut-off should be done first, i.e., before the raft. Immediately, after the raft is complete, aprons on U/s and D/s should be completed.
- (4) Details of raft foundation are given in Article 21.

13.6. Quality Control

13.6.1. Although, the work of culverts and small bridges is simple it is necessary to have quality control in the work of stone/brick masonry and concrete in deck slab, bar bending, etc. Reference may be made to “Guidelines on Quality Systems for Road Bridges”, IRC:SP:47-1998.

13.6.2. Specifications should be in accordance with “Specification for Road and Bridge Works” of Ministry of Road Transport and Highways published by Indian Roads Congress.

13.7. **Setting out of culverts and small bridges** : Setting out of culverts and small bridges should be done from 4 masonry pillars, two in the direction of road and two along the stream, all placed along two center lines. The top of pillars in the direction of road should be at the proposed top level of deckslab. Two lines, one along the direction of stream and the other along the center line of road should be inscribed on one of the pillars and all distances should be measured with respect to these lines. The pillars should be placed sufficiently away from the zone of excavation.

13.8. Masonry Work

13.8.1. All masonry work shall conform to IRC:40. The mortar mix in case of cement sand shall be 1:3, 1:4 or 1:5, whereas, in case of cement lime sand it shall be 1.0:0.5:4.5.

13.8.2. Brick proposed to be used shall be of minimum compressive strength of 7 MPa. However, for rivers with velocity of 4.5 m/s and carrying highly abrasive particles, this shall be increased to 10 MPa.

13.8.3. Brick and stone masonry shall conform to IRC:40.

13.9. Concrete

13.9.1. According to IRC:21, the minimum grade of plain concrete is M 15 of concrete and that of RCC is M 20. The size of metal to be used for RCC slabs and the grading of aggregates are specified in relevant codes. It is advisable to use power driven concrete mixer. Similarly, vibrators should also be made available. Furthermore, precast concrete cover blocks must be provided to ensure bottom cover to reinforcement. Water cement ratio must be limited to 0.45 maximum. In case of use of Plasticiser w/c ratio can be restricted to 0.4. Size of coarse aggregate will be 20 mm for RCC and upto 40 mm for plain concrete.

13.10. **Bar bending :** Lengths of bars and numbers are given in standard drawings. Cutting of bars from available stock must be done carefully. Generally, tendency of cutting bars of required lengths and discarding pieces of shorter lengths give rise to greater wastages. Normally staggered overlaps to the extent of 25 per cent may be provided. Calculated quantities of steel are increased suitably to account for overlaps, its length conforming to IRC:21. Steel chairs should be provided for maintaining correct position of top bars.

ARTICLE 14

STRUCTURAL DETAILS OF SMALL BRIDGES AND CULVERTS

14.1. **Abutment and Wing Wall Sections :** For RCC slab culverts designed for IRC single lane of class 70 R loading or 2-lanes of IRC class A loading, the abutment and wing wall sections upto 4 m height for a minimum bearing capacity of the soil of 16.5 t/m² are given in **Plate 5**. These sections are not applicable for seismic zones IV and V.

The base widths of the abutment and the pier depend on the bearing capacity of the soil. The pressure at the toe of the abutment should be worked out to ensure that the soil is not overstressed.

The pier sections should be made preferably circular in the case of skew crossings.

14.2. **Filling behind the abutments, wing walls and return walls shall conform to IRC:78 as reproduced in Appendix "B".**

14.3. **Unreinforced Masonry Arches :** **Plate 6** shows the details of arch ring of segmental masonry arch bridges without footpaths for spans 6 m and 9 m.

The section of abutment and pier for masonry arch bridges will have to be designed taking into account the vertical reaction, horizontal reaction and the moment at springing due to dead load and live load. Table 14.1 gives the details of horizontal reaction, vertical reaction and moment at springing for arch bridges of span 6 m and 9 m and Table 14.2 gives the influence line ordinates for horizontal reaction, vertical reaction and moment at springing for a unit load placed on the arch ring.

Table 14.1 Vertical Reaction, Horizontal Reaction and Moment at Springing Due to Dead Load of Arch Ring Masonry, Fill Material and Road Crust for One Meter of Arch Measured Along the Transverse Direction (i.e. Perpendicular to the Direction of Traffic) for Right Bridges

Sl. No.	Effective Span (m)	Horizontal Reaction (Tonnes)	Vertical Reaction (Tonnes)	Moment at Springing (Tonne Metres)
(1)	6	9.35	10.92	(+) 0.30
(2)	9	17.40	21.00	(+) 0.47

Notes : 1. Unit weight of arch ring masonry, fill materials and the road crust is assumed as 2.24 t/m³.
2. Positive sign for moment indicates tension on the inside of arch ring.

Table 14.2 Influence Line Ordinates for Horizontal Reaction (H) Vertical Reaction at Support (V_A) and (V_B) and Moment at Springing (M_A) and (M_B) for Unit Load, Say 1 Tonne Located along the Arch Axis at an Angle θ Degrees from the Radius OC. Rise of Arch is One Quarter of Span (Fig. 14.1)

Sl. No.	θ Degree	H in tonnes	V_A in tonnes	V_B in tonnes	M_A (tonnes-m)	M_B (tonnes-m)
(a) Effective Span 6 m						
(1)	0	0.93	0.500	0.500	(-)0.2213	(-)0.2213
(2)	5	0.91	0.577	0.423	(-)0.1388	(-)0.2775
(3)	15	0.75	0.725	0.275	(+)0.0713	(-)0.3075
(4)	25	0.52	0.849	0.152	(+)0.2513	(-)0.2588
(5)	35	0.25	0.940	0.061	(+)0.3413	(-)0.1388
(6)	45	0.05	0.989	0.012	(+)0.2438	(-)0.0338
(7)	53°8'	0	1.000	0	0	0
(b) Effective Span 9 m						
(1)	0	0.93	0.500	0.500	(-)0.3318	(-)0.3318
(2)	5	0.91	0.577	0.423	(-)0.2081	(-)0.4163
(3)	15	0.75	0.725	0.275	(+)0.1069	(-)0.4612
(4)	25	0.52	0.849	0.152	(+)0.3769	(-)0.3881
(5)	35	0.25	0.940	0.061	(+)0.5119	(-)0.2081
(6)	45	0.05	0.989	0.012	(+)0.3656	(-)0.0506
(7)	53°8'	0	1.000	0	0	0

Note : Positive sign for moment indicates tension on the inside of arch ring

14.4. RCC Slabs

14.4.1. The details of RCC slabs to be used for culverts and bridges at right crossings and skew crossings (with and without footpaths) based on MORT&H's standard drawings are given in Plates 7 to 12 as brought out below:

Right crossings (with and without footpaths)

Plate 7 – General Notes

Plate 8 – General arrangement details

Plate 9 – Depth of slab and quantities per span

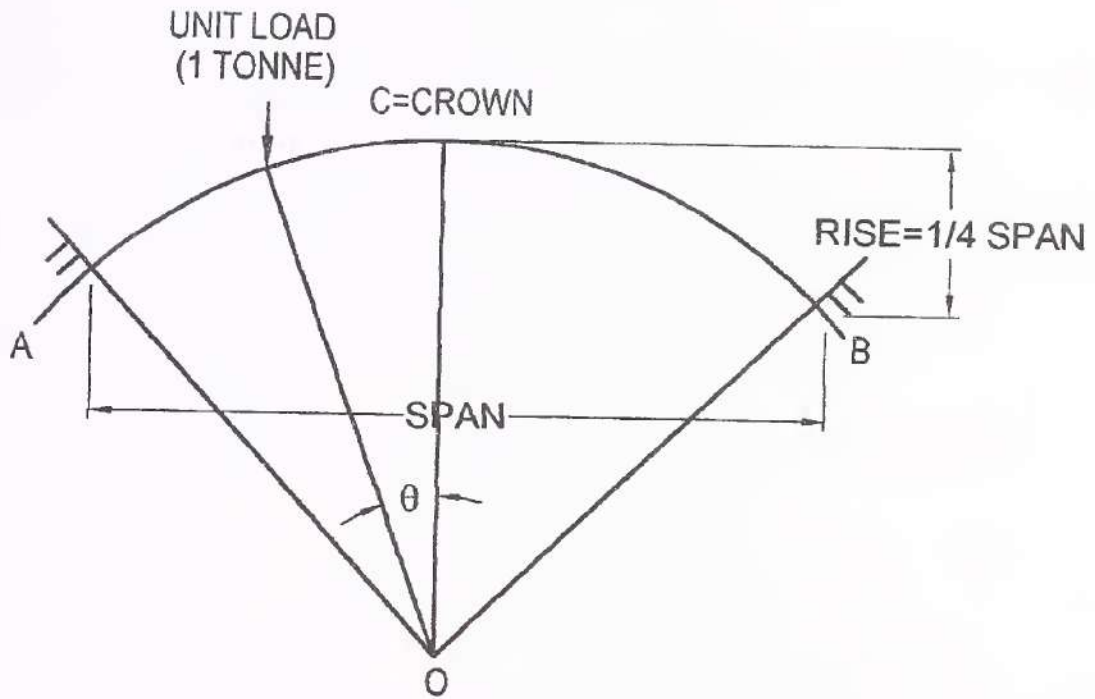

Fig. 14.1

Skew crossings (with and without footpaths)

Plate 10 – General Notes

Plate 11 – General arrangement details

Plate 12 – Depth of slab and quantities per span

14.4.2. For carriageway widths less or more than that prescribed in the **Plates 8 and 11** quantities can be worked out proportionately based on the actual carriageway widths.

14.5. **Box Cell Structures** : The details for single cell box upto 8 m opening, for double cell upto 3 m opening of each cell and triple cell upto 3 m opening of each cell with and without earth cushion for varying bearing capacity upto 20 t/m² based on MORT&H's standard drawings are given in **Plates 13 to 22** as brought out below:

Plate 13 – General Notes

Plate 14 – Index Sheet

Plate 15 to 20 – General arrangement

Plate 21 – Quantities of steel and concrete

Plate 22 – Floor Protection works

14.6. **RCC Pipe Culverts** : The details of pipe culverts of 1 m dia, with single or double pipes having cement concrete or granular materials in bed are given in **Plates 23 to 26**.

14.7. In this document the drawing of abutments and wing walls in plain cement concrete upto 4 m height has been included. For other sub-structure and foundations in R.C.C. and P.C.C./masonry, the design details may be worked out as per relevant IRC Codes depending upon the type of superstructure and foundation conditions.

ARTICLE 15

ELEMENTS OF THE HYDRAULICS OF FLOW THROUGH BRIDGES

15.1. The formulae for discharge passing over broad crested weirs and drowned orifices have been developed ab initio in this section. These formulae are very useful for computing flood discharges from the flood marks left on the piers and abutments of existing bridges and calculating afflux in designing new bridges. It is necessary to be familiar with the rationale of these formulae to be able to apply them intelligently.

15.2. **Broad Crested Weir Formulae applied to Bridge Openings :** In Fig. 15.1, X-X is the water surface profile, and Z-Z the total energy line. At Section 1, the total energy,

$$H = \frac{u^2}{2g} + D_u \quad \dots (15.1)$$

At Section 2, let the velocity head AB be a fraction n of H , i.e.,

$$AB = \frac{v^2}{2g} = nH \quad \dots (15.2)$$

Equating total energies at Sections 1 and 2 ignoring the loss of head due to entry and friction

$$H = AC = AB + BC = nH + BC$$

$$\therefore BC = (1-n)H \quad \dots (15.3)$$

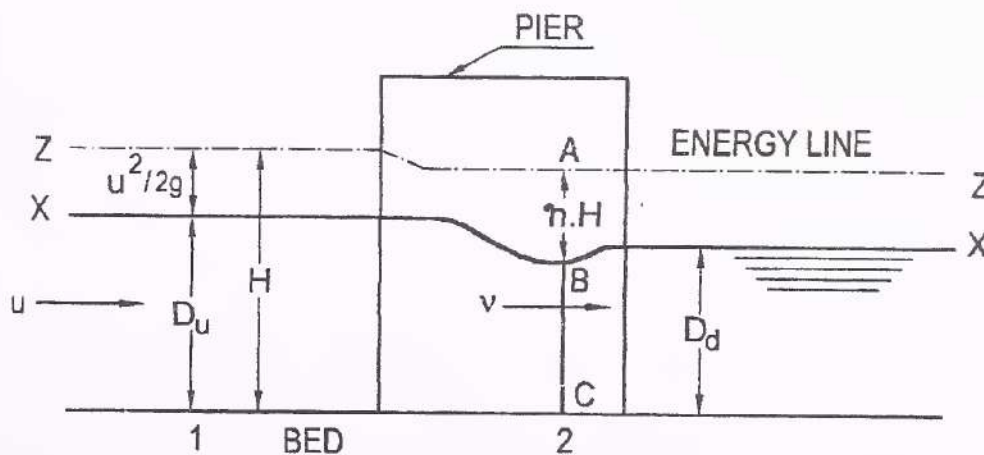

Fig. 15.1

The area of flow at Section 2,

$$\begin{aligned} a &= BC \times \text{linear waterway} \\ &= (1-n)HL \end{aligned}$$

Where L is the linear waterway. From Eq. (15.2) Velocity at Section 2

$$v = (2gnH)^{1/2}$$

Therefore, the discharge through the bridge

$$\begin{aligned} Q &= av \\ &= (1-n)HL(2gnH)^{1/2} \end{aligned}$$

To account for losses in friction, a coefficient C_w may be introduced. Thus,

$$\begin{aligned} Q &= C_w(1-n)HL(2gnH)^{1/2} \\ &= C_w \sqrt{2g} LH^{3/2} \left(\frac{1}{n^{1/2}} - \frac{3}{n^2} \right) \end{aligned} \quad \dots (15.4)$$

The depth BC adjusts itself so that the discharge passing through the section is maximum. Therefore, differentiating

$$\begin{aligned} \frac{dQ}{dn} &= 0 \\ \frac{1}{2} n^{-1/2} - \frac{3}{2} n^{-2} &= 0 \\ \therefore n &= \frac{1}{3} \end{aligned}$$

Putting $n = \frac{1}{3}$ in Eq. (15.4) we get

$$Q = 1.706 C_w LH^{3/2} \quad \dots (15.5a)$$

Comparing with Eq. (15.1)

$$Q = 1.706 C_w L \left(D_u + \frac{u^2}{2g} \right)^{3/2} \quad \dots (15.5b)$$

Since AB is $\frac{1}{3}H$, therefore, BC is $\frac{2}{3}H$, or 66.7 per cent of H .

On exit from the bridge, some of the velocity head is reconverted into potential head due to the expansion of the section and the water surface is raised, so that D_d is somewhat greater than BC , i.e. greater than 66.7 per cent of H . In fact, observations have proved that, in the limiting condition, D_d can be 80 per cent of D_u . Hence, the following rule :

“So long as the afflux ($D_u - D_d$) is not less than $\frac{1}{4} D_d$, the weir formula applies, i.e., Q depends on D_u and is independent of D_d ”.

The fact that the downstream depth D_d has no effect on the discharge Q , nor on the upstream depth D_u when the afflux is not less than $1/4 D_d$ is due to the formation of the "Standing Wave"

The coefficient C_w may be taken as under:-

- | | | |
|-----|--|------|
| (1) | Narrow Bridge opening with or without floors | 0.94 |
| (2) | Wide bridge opening with floors | 0.96 |
| (3) | Wide bridge opening with no bed floors | 0.98 |

15.3. **The Orifice Formulae:** When the downstream depth, D_d is more than 80 per cent of the upstream depth D_u , the weir formula does not hold good, i.e. the performance of the bridge opening is no longer unaffected by D_d .

In Fig. 15.2, X-X is the water surface line and Z-Z the total energy line.

Apply Bernouli's Equation to points 1 and 2, ignoring the loss of head (h) due to entry and friction.

$$D_u + \frac{u^2}{2g} = D^1 + \frac{v^2}{2g}$$

or

$$\frac{v^2}{2g} = D_u - D^1 + \frac{u^2}{2g}$$

Then

$$v = \left[\sqrt{2g} (D_u - D^1) + \frac{u^2}{2g} \right]$$

Put $D_u - D = h^1$

Then,

$$v = \sqrt{2g} \left(h^1 + \frac{u^2}{2g} \right)^{1/2}$$

The discharge through the Section 2,

$$Q = a v$$

Substituting

$$Q = LD^1 \sqrt{2g} \left(h^1 + \frac{u^2}{2g} \right)^{1/2} \quad \dots (15.6)$$

Now the fractional difference between D^1 and D_d is small. Put D_d for D^1 in Eq. (15.6).

$$Q = LD_d \sqrt{2g} \left(h^1 + \frac{u^2}{2g} \right)^{1/2} \quad \dots (15.7)$$

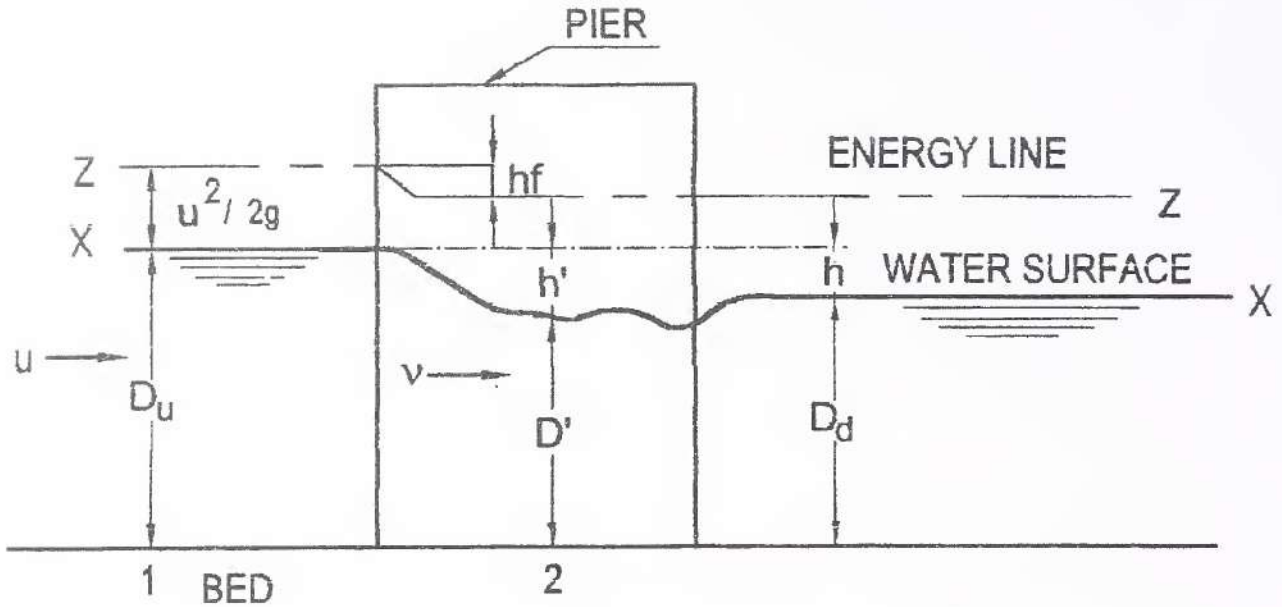

Fig. 15.2

In the field it is easier to work in terms of $h = D_u - D_d$ instead of h' . But h is less than h' as on emergence from the bridge the water surface rises, due to recovery of some velocity energy as potential head. Suppose $eu^2/2g$ represents the velocity energy that is converted into potential head.

Then

$$h' = h + \frac{eu^2}{2g}$$

Substituting in equation (15.7)

$$Q = LD_d \sqrt{2g} \left(h + (e+1) \frac{u^2}{2g} \right)^{1/2}$$

Now introduce a co-efficient C_0 to account for losses of head through bridge, we get.

$$Q = C_0 \sqrt{2g} LD_d \left(h + (1+e) \frac{u^2}{2g} \right)^{1/2} \quad \dots (15.8)$$

For values of e and C_0 , see Figs. 15.3 and 15.4^[10]

15.4. **In Conclusion :** Let us get clear on some important points

- (1) In all these formulae D_d is not affected in any way by the existence of the bridge. It depends only on the conveyance factor and slope of tail race. D_d has, therefore, got to be actually measured or calculated from area – slope data of the channel as explained already in Article 7.
- (2) The Weir Formula applies only when a standing wave is formed, i.e., when the afflux ($h = D_u - D_d$) is not less than $\frac{1}{4} D_d$.

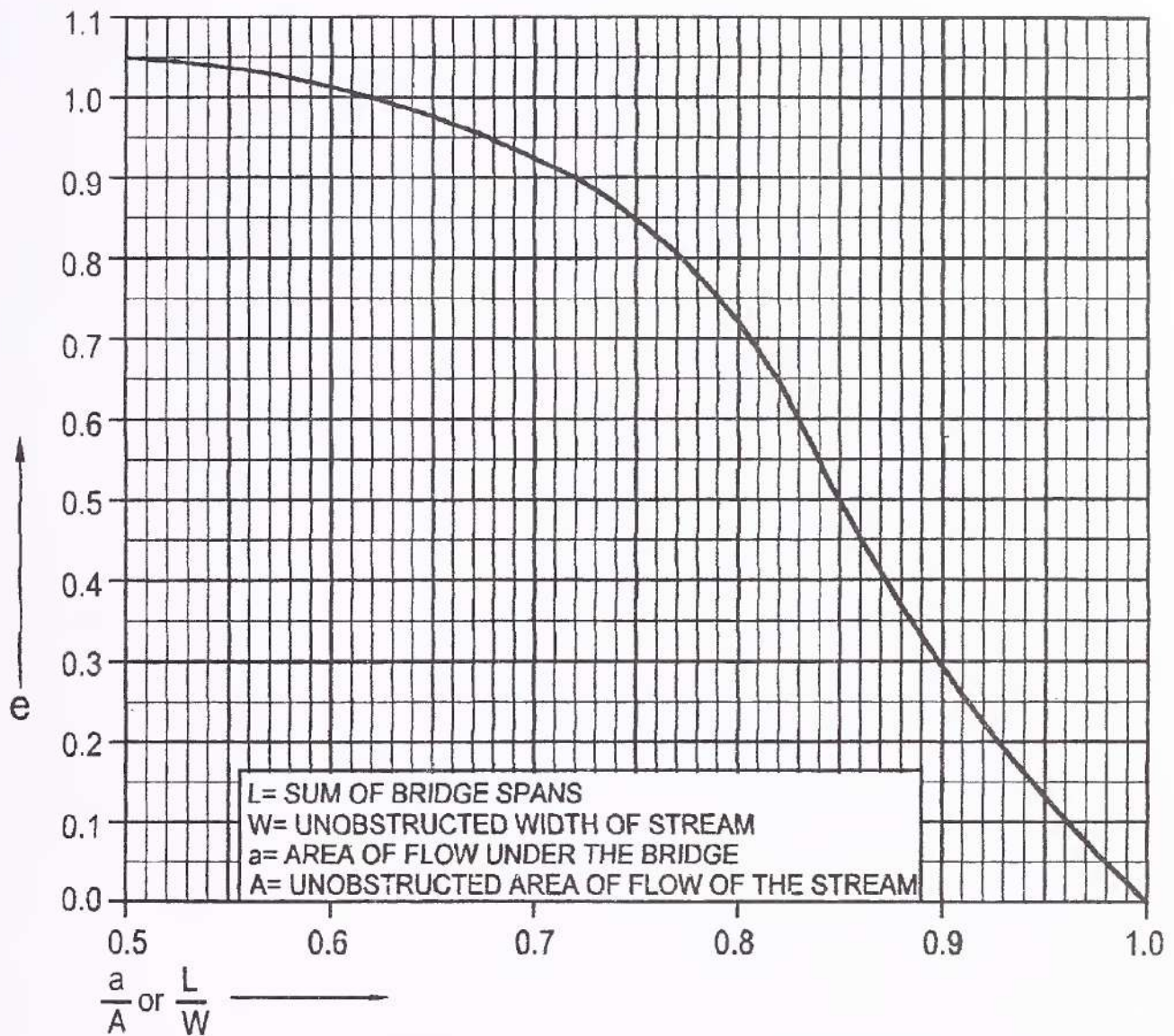

Fig. 15.3 Elements of the hydraulics of flow through bridges
The orifice formula coefficient "e"

- (3) The Orifice Formulae with the suggested values of C_o and e should be applied when the afflux is less than $1/4 D_d$.

15.5. Examples have been worked out in Articles 16 and 17 to show how these formulae can be used to calculate afflux and discharge under bridges.

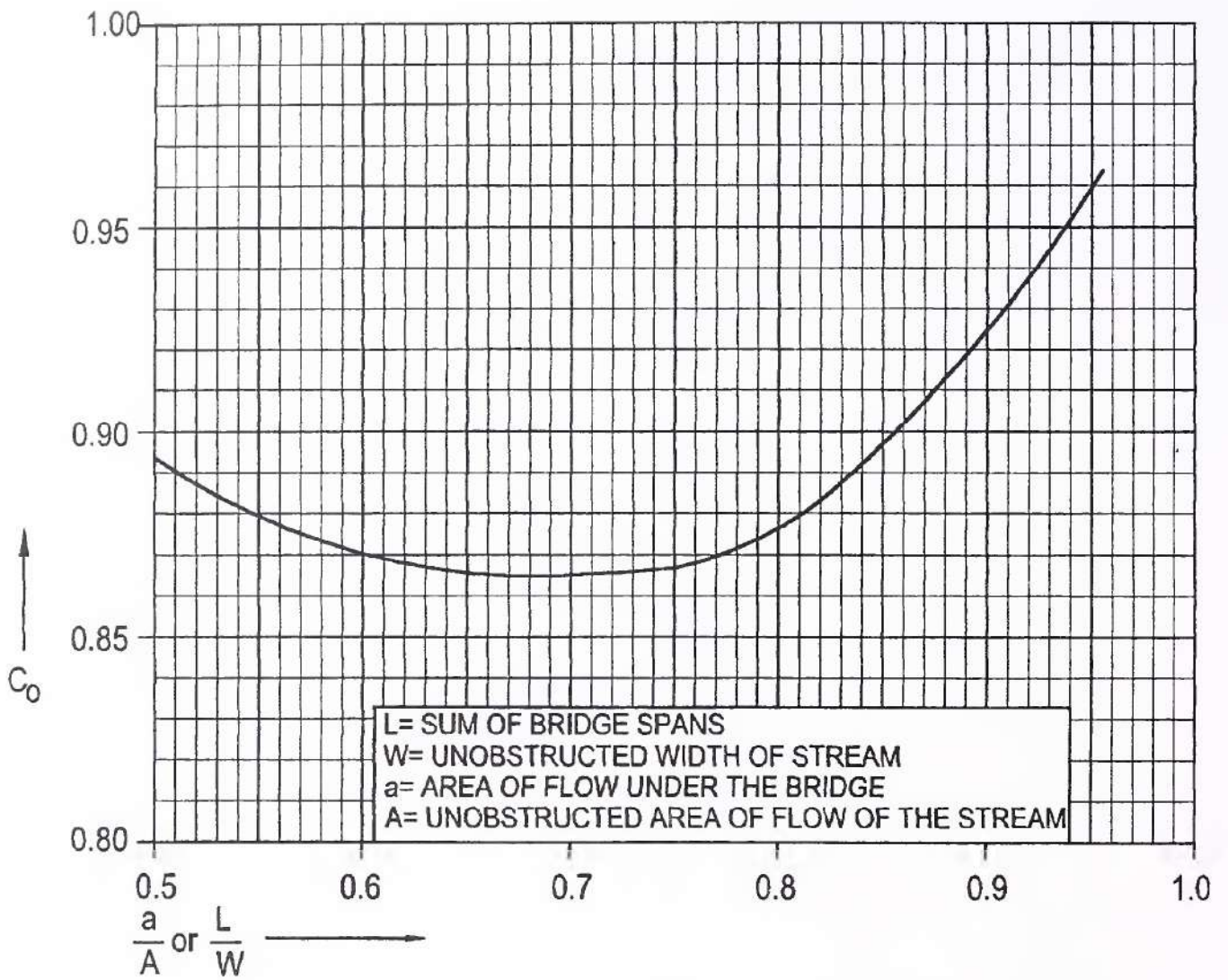

Fig. 15.4 The Orifice Formula Coefficient “ C_o ”

ARTICLE 16

AFFLUX

16.1. The afflux at a bridge is the heading up of the water surface caused by it. It is measured by the difference in levels of the water surfaces upstream and downstream of the bridge (Fig. 16.1).

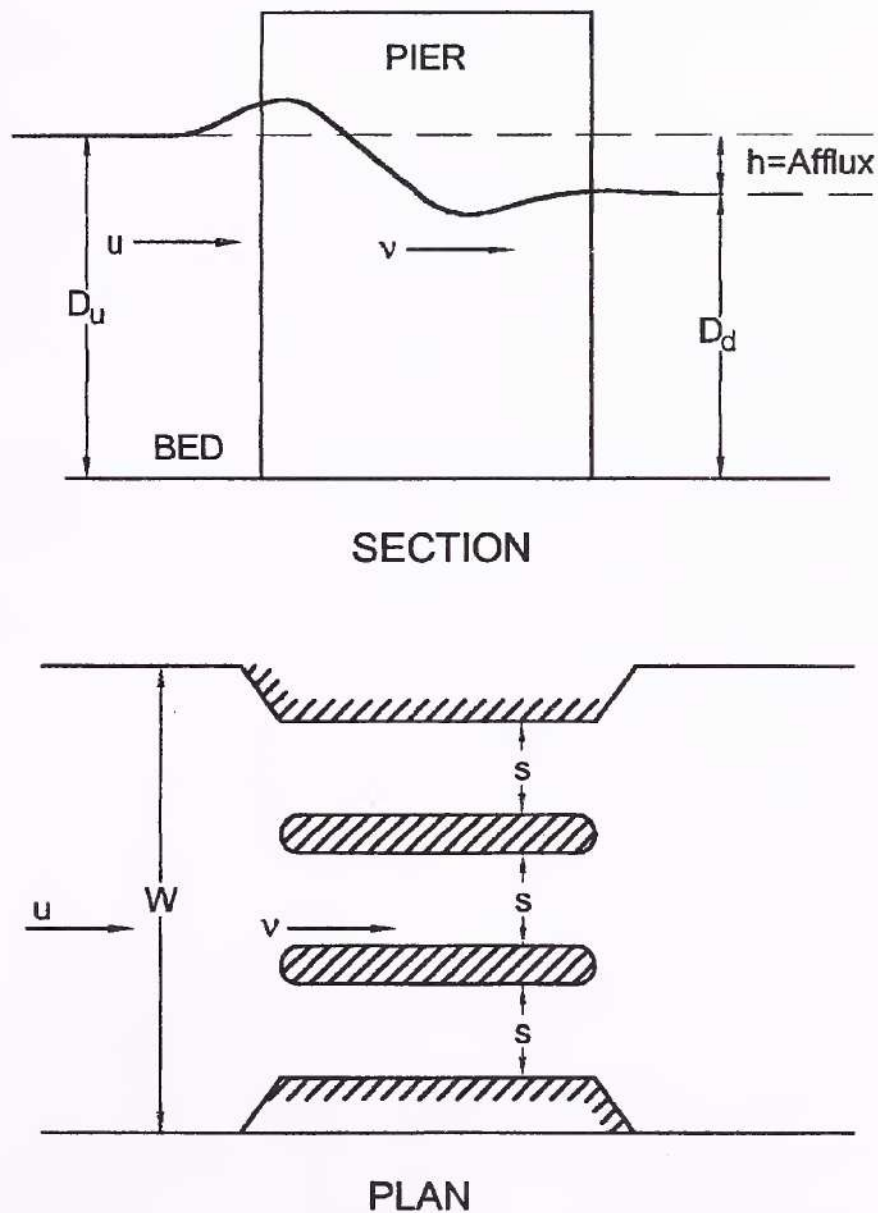

Fig. 16.1

16.2. When the waterway area of the openings of a bridge is less than the unobstructed natural waterway area of the stream, i.e., when the bridge contracts the stream, afflux occurs. Contraction of the stream is normally not done, but under some circumstances it is taken recourse to,

if it leads to ponderable economy. Also, in the case of some alluvial streams in plains the natural stream width may be much in excess of that required for regime. When spanning such a stream, it has to be contracted to, more or less, the width required for stability by providing training works.

16.3. Estimating afflux is necessary to see its effect on the ‘clearance’ under the bridge, on the regime of the channel upstream of the bridge; and on the design of training works.

16.4. For calculating afflux we must know (1), the discharge Q , (2) The unobstructed width of the stream W , (3) the linear waterway of the bridge L , and (4) the average depth downstream of the bridge D_d .

16.5. The downstream depth D_d is not affected by the bridge : it is controlled by the conveyance factor and slope of the channel below the bridge. Also, the depth, that prevails at the bridge site before the construction of the bridge, can be assumed to continue to prevail just downstream of the bridge after its construction. Thus, D_d is the depth that prevails at the bridge site before its construction. To estimate afflux we must know D_d . In actual problems, D_d is either given or can be calculated from the data supplied.

16.6. **Example :** A bridge, having a linear waterway of 25 m, spans a channel 33 m wide carrying a discharge of 70 m³/s. Estimate the afflux when the downstream depth is 1 m.

$$D_d = 1\text{ m} ; W = 33\text{ m} ; L = 25\text{ m}$$

Discharge through the bridge by the Orifice Formula.

$$Q = C_o \sqrt{2g} L D_d \sqrt{\left(h + (1 + e) \frac{u^2}{2g} \right)}$$

$$\frac{L}{W} = \frac{25}{33} = 0.757$$

Afflux Corresponding to this, $C_o = 0.867$, $e = 0.85$, $g = 9.8\text{ m/sec}^2$

$$70 = 0.867 \times 4.43 \times 25 \times 1 \sqrt{h + \frac{1.85u^2}{2g}}$$

$$\therefore h + 0.0944u^2 = 0.53 \quad \dots (16.1)$$

Also, just upstream of the bridge

$$Q = W (D_d + h) u$$

$$70 = 33 (1 + h) u$$

$$h = \frac{70}{33u} - 1 \quad \dots (16.2)$$

Substituting for h from (16.2) in (16.1) and rearranging

$$u = 0.0617 u^3 + 1.386 \quad \therefore \quad u = 1.68 \text{ m/sec}$$

Substituting for u in (16.1)

$$h = 0.263 \text{ m}$$

Alternatively, assume that h is more than $\frac{1}{4} D_d$

and apply the Weir Formula

$$Q = 1.706 C_w L H^{3/2}$$

$$70 = 1.706 \times 0.94 \times 25 \times H^{3/2}$$

$$H = 1.45 \text{ m}$$

$$H = D_u + \frac{u^2}{2g} = D_u \quad (\text{approx.})$$

$$\text{Or ; } D_u = 1.45 \text{ m (approx.)}$$

Now,

$$Q = W D_u u$$

$$\therefore 70 = 33 \times 1.45 u$$

$$\therefore u = 1.46; \quad \frac{u^2}{2g} = 0.1086 \text{ m}$$

$$H = D_u + \frac{u^2}{2g}$$

i.e.

$$1.45 = D_u + 0.1086$$

$$D_u = 1.3414 \text{ m}$$

$$h = D_u - D_d = 1.3414 - 1.0 = 0.3414 \text{ m}$$

Adopt $h = 0.3414 \text{ m}$. Since h is actually more than $\frac{1}{4} D_d$, therefore, the value of afflux arrived by the Weir Formula is to be adopted.

16.7. Example : The unobstructed cross-sectional area of flow of a stream of 90 m^2 and the width of flow is 30 m. A bridge of 4 – spans of 6 m clear is proposed across it. Calculate the afflux when the discharge is $280 \text{ m}^3/\text{s}$.

$$w = 30 \text{ m; } L = 24 \text{ m, } D_d = \frac{90}{30} = 3.00 \text{ m}$$

The depth before the construction of the bridge is the depth downstream of the bridge after its construction. Hence, $D_d = 3.00 \text{ m}$

$$\frac{L}{W} = \frac{24}{30} = 0.8$$

By the Orifice Formula the discharge through the bridge

$$280 = 0.877 \times 4.43 \times 24 \times 3.00 \times \sqrt{h + 1.72 \frac{u^2}{2g}}$$

$$280 = 279.7 \sqrt{h + 1.72 \frac{u^2}{2g}}$$

$$h + \frac{1.72 u^2}{2g} = 1 \quad \dots (16.3)$$

Now, the discharge just upstream of the bridge

$$280 = (3 + h) 30 u \quad \dots (16.4)$$

Putting for h from (16.4) in (16.3) and rearranging

$$u = 2.33 + .02195 u^3$$

$$u = 2.81 \text{ m/sec}$$

Putting for u in (16.4)

$$h = 0.32 \text{ m} < \frac{1}{4} D_d$$

16.8. **Example :** A bridge of 3 spans of 8 m each is proposed across a stream, whose unobstructed width is 36 m, slope 1/2000 and discharge 400 m³/sec. Calculate the afflux (n=0.03) (Fig. 16.2).

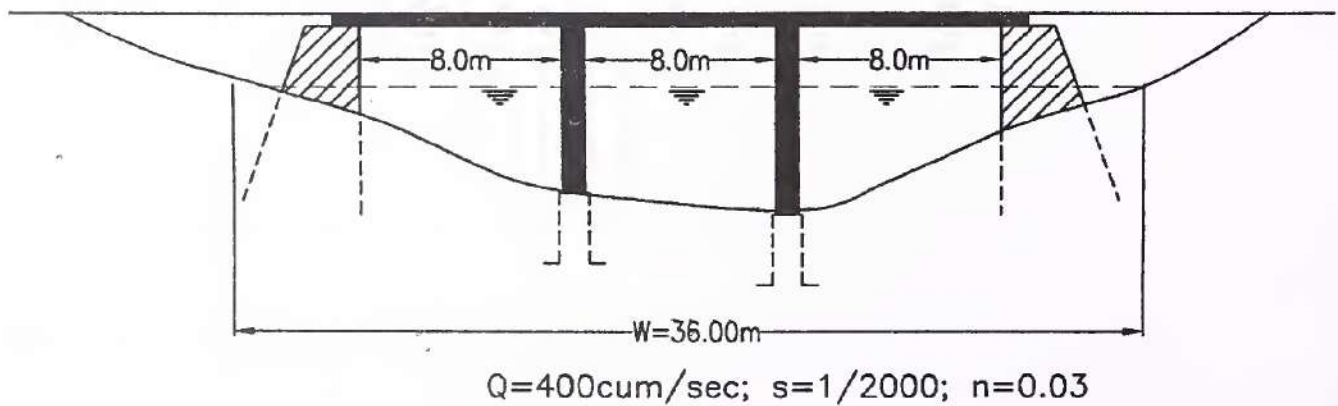

Fig. 16.2

We have first to find D_d

$$Q = AV = (RP) V = RWV$$

$$\therefore RV = \frac{Q}{W} = \frac{400}{36} = 11.11$$

Knowing $n = 0.03$; $S = 1/2000$, read velocity for various values of R from **Plate 3** and select that pair whose product is 11.11. Thus, we get.

$$R = 5.1$$

$$V = 2.18$$

$$\text{Take } D_d = R = 5.1 \text{ m}$$

Now, $W = 36 \text{ m}$, $L = 24 \text{ M}$, $D_d = 5.1 \text{ m}$

$$\frac{L}{W} = \frac{24}{36} = 0.67 \quad \text{Therefore, } C_o = 0.865; e = 0.95$$

By the Orifice Formula, the discharge through the bridge

$$Q = C_o \sqrt{2g} L D_d \left[h + (1+e) \frac{u^2}{2g} \right]^{1/2}$$

$$400 = 0.865 \times \sqrt{2 \times 9.8} \times 24 \times 5.1 \left[h + 1.95 \frac{u^2}{2g} \right]^{1/2}$$

$$0.8528 \left[h + \frac{0.975u^2}{g} \right]^{1/2}$$

$$\text{or } h + 0.009 u^2 = 0.7272 \quad \dots (16.5)$$

The discharge just upstream of the bridge

$$400 = 36(5.1 + h)u$$

$$\text{i.e., } h = \frac{11.11}{u} - 5.1 \quad \dots (16.6)$$

Put value for h from (16.6) in (16.5) and rearrange

$$u - 0.017 u^3 = 1.90$$

$$\therefore u = 2.05 \text{ m/sec}$$

Put this value of u in (16.6), we get,

$$h = \frac{11.11}{2.05} - 5.1 = 0.31 \text{ m}$$

ARTICLE 18

OVERTOPPING OF THE BANKS

18.1. In plains where the ground slopes are gentle and the natural velocities of flow in streams are low, the flood water may spill over one or both the banks of the stream at places.

18.2. **Height of Approach Roads :** Consider the case where main channel carries the bulk of the discharge and a small fraction of it flows over the banks somewhere upstream of the bridge. If the overflow strikes high ground at a short distance from the banks, it can be forced back into the stream and made to pass through the bridge. This can be done by building the approach roads of the bridge solid and high so that they intercept the overflow. In this arrangement, the linear waterway of the bridge must be ample to handle the whole discharge without detrimental afflux. Also, the top level of the approach road must be high enough to prevent overtopping. If the velocity of the stream is V (m/s), the water surface level, where it strikes the road embankment, will be $\frac{V^2}{19.6}$ (m) higher than HFL in the stream at the point, where the overflow starts. This arrangement is,

therefore, normally feasible where the stream velocity is not immoderately high.

18.3. **Subsidiary or Relief Culverts :** Sometimes, however, the overflow spreads far and away from the banks. This is often the case in alluvial plains, where the ground level falls continuously away from the banks of the stream. In such cases, it is impossible to force the overflow back into the main stream. The correct thing to do is to pass the overflow through relief culverts at suitable points in the road embankment. These culverts have to be carefully designed. They should not be too small to cause detrimental ponding up of the overflow, resulting in damage to the road or some property, nor, should they be so big as to attract the main current.

18.4. **Dips and Breaching Sections in Approach Roads :** It is sometimes feasible as well as economical to provide permanent dips (or alternatively breaching sections) in the bridge approaches to take excessive overflows in emergencies. The dips or breaching sections have to be sited and designed so that the velocity of flow through them does not become erosive, cutting deep channels and ultimately leading to the shifting of the main current.

18.5. **Retrogression of Levels :** Suppose water overflows a low bank somewhere upstream of the bridge and after passing through a relief culvert, rejoins the main stream somewhere lower down. When the flood in the main channel subsides, the ponded up water at the inlet of the subsidiary culvert gets a free fall. Under such conditions deep erosion can take place. A deep channel is formed, beginning at the outfall in the mains stream and retrogressing towards the culvert. This endangers the culvert. To provide against this, protection has to be designed downstream of the culvert so as to dissipate the energy of the falling water on the same lines as is done on irrigation falls. That is a suitable cistern and baffle wall should be added for dissipating the energy and the issuing current should be stilled through a properly designed expanding flume.

ARTICLE 19

PIPES AND BOX CULVERTS

19.1. Feasibility of Pipe and Box Culverts Flowing Full

19.1.1. Some regions along plain consist of vast flat without any deep and defined drainage channels in it. When the rain falls, the surface water moves in some direction in a wide sheet of nominal depth. So long as this movement of water is unobstructed, no damage may occur to property or crops. But when a road embankment is thrown across the country intercepting the natural flow, water ponds up on one side of it. Relief has then to be afforded from possible damage from this ponding up by taking the water across the road through causeways or culverts.

19.1.2. In such flat regions the road runs across wide but shallow dips and, therefore, the most straightforward way of handling the surface flow is to provide suitable dips (i.e., causeways) in the longitudinal profile of the road and let water pass over them.

19.1.3. There may, however, be cases where the above solution is not the best. Some of its limitations may be cited. Too many causeways or dips detract from the usefulness of the road. Also, the flow of water over numerous sections of the road, makes its proper maintenance problematic and expensive. Again, consider the case of a wet cultivated or waterlogged country (and flat plains are quite often swampy and waterlogged) where the embankment has necessarily got to be taken high above the ground. Frequent dipping down from high road levels to the ground produces a very undesirable road profile. And, even cement concrete slabs, in dips across a waterlogged country, do not rest evenly on the mud underneath them. Thus, it will appear that constructing culverts in such circumstances should be a better arrangement than providing dips or small causeways.

19.1.4. After we have decided that a culvert has to be constructed on a road lying across some such country, we proceed to calculate the discharge by using one of the run off formulae, having due regard to the nature of terrain and the intensity of rainfall as already explained in Article-4. But the natural velocity of flow cannot be estimated because (i) there is no defined cross-section of the channel from which we may take the area of cross-section and wetted perimeter and (ii) there is no measurable slope in the drainage line. Even where we would calculate or directly observe the velocity, it may be so small that we could not aim at passing water through the culvert at that velocity, because the area of waterway required for the culvert $\left(A = \frac{Q}{V} \right)$ is prohibitively large. In such cases the design has to be based on an increased velocity of flow through the culvert and to create the velocity the design must provide for heading up at the inlet end of the culvert. Economy, in design being the primary consideration, the correct practice, indeed is to design a pipe or a box culvert on the assumption that water at the inlet end may head upto a predetermined safe level above the top of the inlet opening. This surface level of the headed up water at the upstream end has to be so fixed that the road bank should not be overtopped, nor any property in the flood plain damaged.

Next, the level of the downstream water surface should be noted down. This will depend on the size of the slope of the leading out channel and is normally, the surface level of the natural unobstructed flow at the site, that prevails before the road embankment is constructed.

After this we can calculate the required area of cross-section of the barrel of the culvert by applying the principles of hydraulics discussed in this Article.

19.1.5. The procedure set out above is rational and considerable research has been carried out on the flow of water through pipe and box culverts, flowing full.

19.1.6. In the past, use was extensively made of empirical formulae which gave the ventway area required for a culvert to drain a given catchment area. Dun's Drainage Table is one of the class and is purely empirical. This table is still widely used, as it saves the trouble of hydraulic calculations. But it is unfortunate that recourse is often taken rather indiscriminately to such short cuts, even where other more accurate and rational procedure is possible and warranted by the expense involved. Dun's Table or other in that class, should NOT be used until suitable correction factors have been carefully evolved from extensive observations (in each particular region with its own singularities of terrain and climate) of the adequacy or otherwise of the existing culverts vis-à-vis their catchment area.

19.1.7. Considerations of economy require that small culverts, in contrast with relatively larger structures across defined channels, need not be designed normally to function with adequate clearance for passing floating matter. The depth of a culvert should be small and it does not matter if the opening stops appreciably below the formation level of the road. Indeed, it is correct to leave it in that position and let it function even with its inlet submerged. This makes it possible to design low abutments supporting an arch or a slab, or alternatively, to use round pipes or square box barrels.

19.1.8. High headwall should not be provided for retaining deep over-fills. Instead of this the length of the culverts should be increased suitably so that the road embankment, with its natural slopes, is accommodated without high retaining headwalls.

19.1.9. Where masonry abutments supporting arches or slabs are designed for culverts functioning under "head", bed pavements must be provided. And, in all cases, including pipe and box culverts, adequate provision must be made at the exit against erosion by designing curtain walls. Where the exit is a free fall, a suitable cistern and baffle wall must be added for the dissipation of energy and stilling of the ensuring current.

19.2. Hydraulics of the Pipe and Box Culverts Flowing Full

19.2.1. **The permissible heading up at the inlet :** It has been explained already that where a defined channel does not exist and the natural velocity of flow is very low, it is economical to design a culvert as consisting of a pipe or a number of pipes of circular or rectangular section functioning with the inlet submerged. As the flood water starts heading up at the inlet, the velocity through the barrel goes on increasing. This continues till the discharge passing through the culvert equals the discharge coming towards the culvert. When this state of equilibrium is reached the upstream water level does not rise any higher.

For a given design discharge the extent of upstream heading up depends on the ventway of the culvert. The latter has to be so chosen that the heading up should not go higher than a predetermined safe level. The criterion for safety being that the road embankment should not be overtopped, nor any property damaged by submergence. The fixing of this level is the first step in the design.

19.2.2. **Surface level of the tail race :** It is essential that the HFL in the outfall channel near the exit of the culvert should be known. This may be taken as the HFL prevailing at the proposed site of the culvert before the construction of the road embankment with some allowance for the concentration of flow caused by the construction of the culvert.

19.2.3. **The operating head when the culverts flow full :** In this connection the cases that have to be considered are illustrated in Fig. 19.1. In each case the inlet is submerged and the culvert flows full. In case (a) the tail race water surface is below the crown of the exit and in case (b) it is above that. The operating head in each case is marked "H". Thus, we see that : "When the culvert flows full, the operating head, H, is the height of the upstream water level measured from the surface level in the tail race or from the crown of the exit of the culvert whichever level is higher".

19.2.4. **The velocity generated by "H" :** The operating head "H" is utilized in (i) supplying the energy required to generate the velocity of flow through the culvert (ii) Forcing water through the inlet of the culvert, and (iii) overcoming the frictional resistance offered by the inside wetted surface of the culvert.

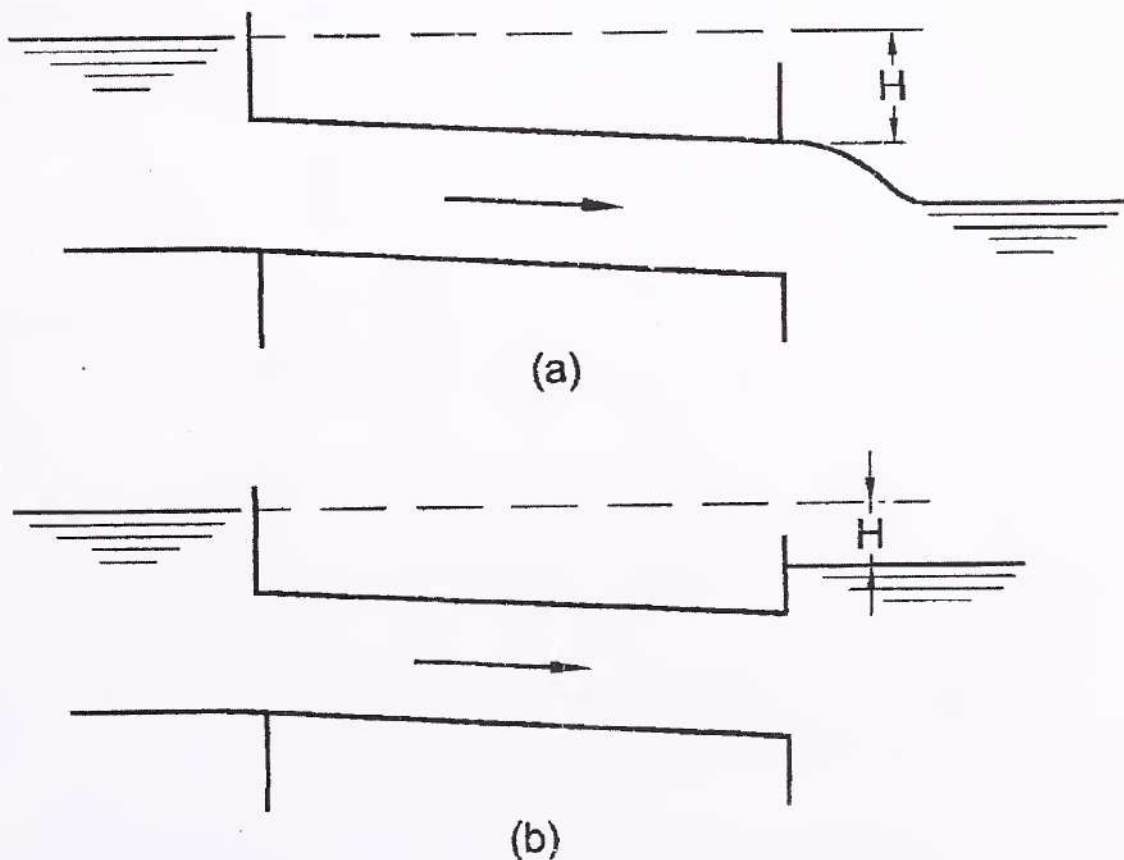

Fig. 19.1

If the velocity through the pipe is v , the head expended in generating is $\frac{v^2}{2g}$.

As regards the head expended at the entry it is customary to express it as a fraction

K_e of the velocity head $\frac{v^2}{2g}$. Similarly, the head required for overcoming the friction of the pipe is expressed as a fraction K_f of the $\frac{v^2}{2g}$. From this it follows that:

$$H = [1 + K_e + K_f] \frac{v^2}{2g} \quad \dots (19.1)$$

From this equation we can calculate the velocity v , which a given head H will generate in a pipe flowing full, if we know K_e and K_f .

19.2.5. Values of K_e and K_f : K_e principally depends on the shape of the inlet. The following values are commonly used:

$$\begin{aligned} K_e &= 0.08 \text{ for bevelled or} \\ &\quad \text{Bell – mouthed entry} \\ &= 0.505 \text{ for sharp edged} \\ &\quad \text{entry} \end{aligned} \quad \dots (19.2)$$

As regards K_f it is a function of the Length L of the culvert, its hydraulic mean radius R , and the co-efficient of rugosity n of its surface.

The following relationship exists between K_f and n :

$$K_f = \frac{14.85n^2}{R^{1/3}} \times \frac{L}{R} \quad \dots (19.3)$$

For cement concrete circular pipes or cement plastered masonry culverts of rectangular section, with the co-efficient of rugosity $n = 0.015$, the above equation reduces to:

$$K_f = \frac{0.0334L}{R^{1.33}} \quad \dots (19.4)$$

The graphs in **Fig. 19.2** are based on Equation 19.4. For a culvert of known sectional area and length, K_f can be directly read from these graphs.

19.2.6. Values of K_e and K_f modified through research: Considerable research has recently been carried out on the head lost in flow through pipes. The results have unmistakably demonstrated the following:-

The entry loss co-efficient K_e depends not only on the shape of the entry but also on the size of entry and the roughness of its wetted surface. In general, K_e increases with an increase in the size of the inlet.

Also K_f the friction loss co-efficient, is not independent of K_e . Attempts to make the entry efficient repercuss adversely on the frictional resistance to flow offered by the wetted surface of the barrel. In other words, if the entry conditions improve (i.e. if K_e decreases), the friction of the barrel increases (i.e. K_f increases). This phenomenon can be explained by thinking of the velocity distribution inside the pipe. When the entry is square and sharp edged, high velocity lines are concentrated nearer the axis of the barrel, while the bell-mouthed entry gives uniform distribution of velocity over the whole section of the barrel. From this it follows that the average velocity being the same in both cases, the velocity near the wetted surface of the pipe will be lower for square entry than for bell-mouthed entry. Hence, the frictional resistance inside the culvert is smaller when the entry is square than when it is bell-mouthed. Stream lining the entry is, therefore, not an unmixed advantage.

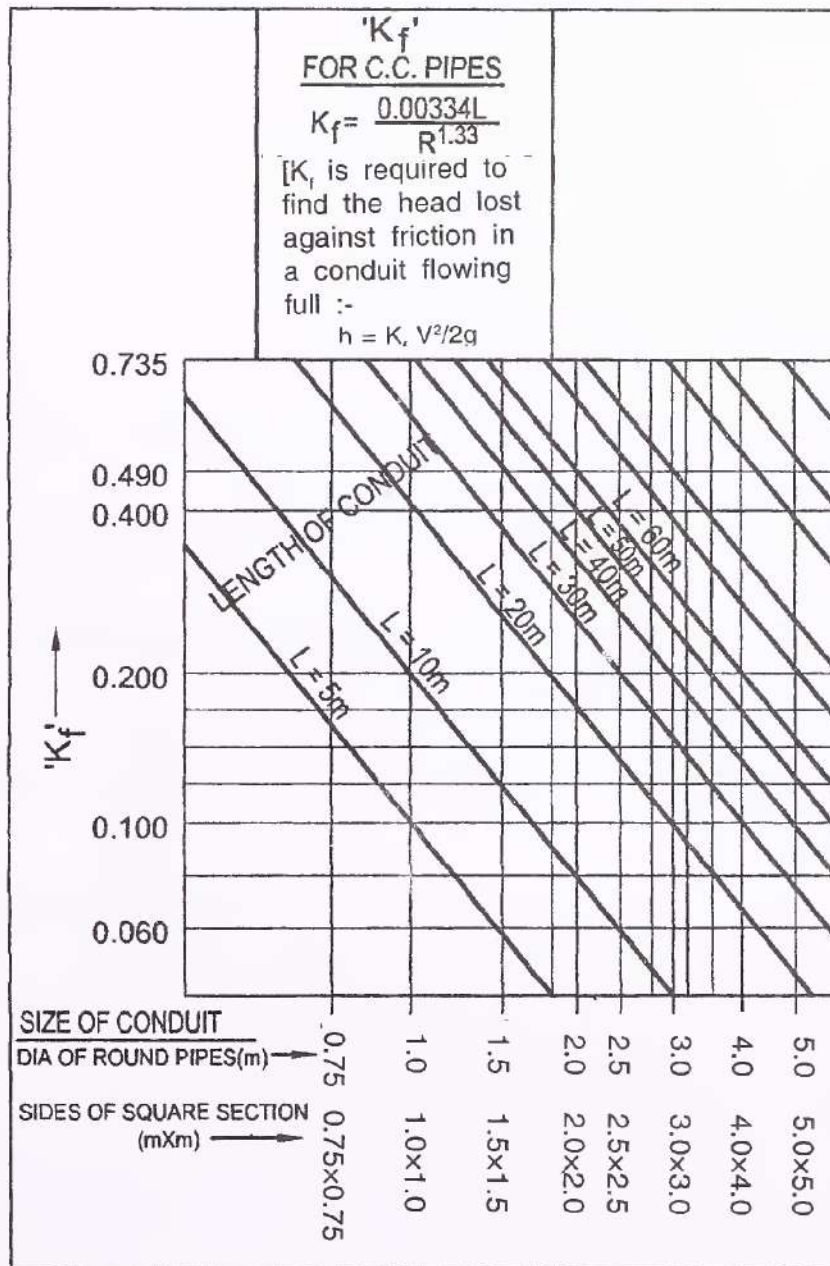

Fig. 19.2

Consequently, it has been suggested that the values of K_e and K_f should be as given in Table 19.1.

Table 19.1 Values of K_e and K_f ¹⁹¹

Entry and friction	Circular pipes		Rectangular culverts	
	Square entry	Bevelled entry	Square entry co-efficient	Bevelled entry
$K_e =$	$1.107 R^{0.5}$	0.1	$0.572 R^{0.3}$	0.05
$K_f =$	$0.00394L/R^{1.2}$	$0.00394L/R^{1.2}$	$0.0035 L/R^{1.25}$	$0.0035L/R^{1.25}$

19.2.7. Design calculations: We have said that

$$H = (1 + K_e + K_f) \frac{v^2}{2g}$$

$$\text{i.e. } v = 4.43 \left(\frac{H}{1 + K_e + K_f} \right)^{1/2} \quad \dots (19.5)$$

$$Q = A \times 4.43 \left(\frac{H}{1 + K_e + K_f} \right)^{1/2}$$

Suppose we know the operating head H and the length of the barrel L , and assume that the diameter of a round pipe or the side of a square box culvert is D .

From D calculate the cross-sectional area A and the hydraulic mean radius R of the culvert.

Now from R and L compute K_e and K_f using appropriate functions from Table 19.1. Then, calculate Q from Equation (19.5). If this equals the design discharge, the assumed size of the culvert is correct. If not, assume a fresh value of D and repeat.

19.2.8. Design chart (Plate 27) : Equation (19.5) may be written as

$$Q = \lambda \sqrt{2g H} \quad \dots (19.6)$$

$$\lambda = \frac{A}{(1 + K_e + K_f)^{1/2}} \quad \dots (19.7)$$

It is obvious that all components of λ in Equation (19.7) are functions of the cross-section, length, roughness, and the shape of the inlet of the pipe. Therefore, λ represents the conveying capacity of the pipe and may be called the 'Conveyance Factor'. The discharge, then depends on the conveyance factor of the pipe and the operating head. In Plate 26, curves have been constructed from equation (19.7) from which Q can be directly read for any known values of λ and H .

Also, in the same Plate, Tables are included from which λ can be taken for any known values of (i) length, (ii) diameter in case of circular pipes or sides in case of rectangular pipes, and

(iii) conditions of entry, viz., sharp-edged or round. The material assumed is cement, concrete and values of K_e and K_f used in the computation are based on functions in Table 19.1.

The use of **Plate 27** renders the design procedure very simple and quick. Examples will now follow to illustrate.

19.2.9. Example data :

- (1) Circular cement concrete pipe
flowing full with bevelled entry
- (2) Operating head = 1 m
- (3) Length of the pipe = 25 m
- (4) Diameter = 1 m

Find the discharge.

See, in **Plate 27**, the Table for circular pipes with rounded entry.

For $L=25$ m and $D=1$ m, the conveyance factor

$$\lambda=0.618$$

Now refer to the curves in the same Plate. For $\lambda = 0.618$ and $H=1$ m

$$Q=2.72 \text{ m}^3/\text{sec}$$

19.2.10. **Example :** Design a culvert consisting of cement concrete circular pipes with bevelled entry and flowing full, given: (**Fig. 19.3**).

Discharge	=	10 m ³ /sec
R.L. of ground in metres	=	100.00
H.F.L of tail race in metres	=	100.80
Permissible heading up at inlet R.L.	=	101.80
Length of culvert	=	20 m

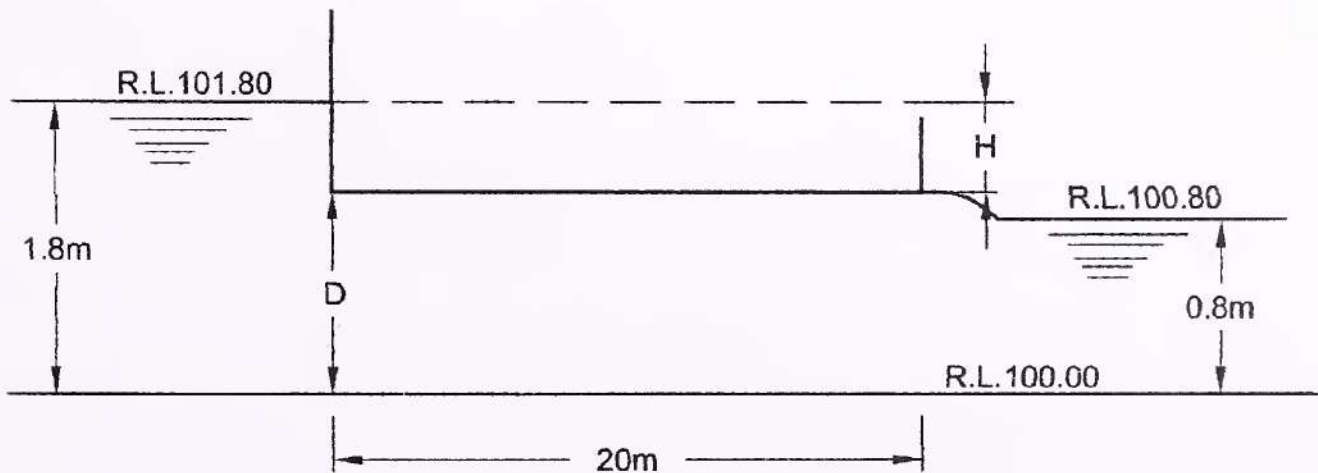

Fig. 19.3

Since we shall try pipes of diameters exceeding 0.8 m, the culvert will function as sketched:

Assumed value of $D = (1) 1 \text{ m}; (2) 1.5 \text{ m};$

Corresponding

$$H = 1.8 - D = (1) 0.8 \text{ m}; (2) 0.3 \text{ m};$$

Discharge per pipe

From **Plate 27**, $Q = (1) 2.54 \text{ m}^3/\text{s}; (2) 3.5 \text{ m}^3/\text{s}$

Number of pipes

Require $10/Q = (1) 3.93; (2) 2.85$

Say 4 Say 3

Hence, 4 pipes of 1 metre diameter will suit.

ARTICLE 20

PROTECTION WORK AND MAINTENANCE

20.1. Floor Protection Works:

In case structures founded on erodible soil are protected against scour by floor protection works, the following is considered as sound practice.

20.1.1. For structures where adoption of shallow foundations becomes economical by restricting the scour, floor protection may be provided. The floor protection will comprise of rigid flooring with curtain walls and flexible apron so as to check scour, washing away or disturbance by piping action, etc. Usually performance of similar existing works is the best guide for finalizing the design of new works. However, the following minimum specification for floor protection shall be followed while designing new structures subject to the general stipulation that post protection works velocity under the structures does not exceed 2 m/s and the intensity of discharge is limited to $2\text{m}^3/\text{m}$.

20.1.2. Suggested Specifications:

20.1.2.1. Excavation for laying foundation and protection works should be carried out as per specifications under proper supervision. Before laying the foundation and protection works the excavated trench should be thoroughly inspected by the Engineer-in-Charge to ensure that:

- (a) There are no loose pockets, unfilled depressions left in the trench.
- (b) The soil at the founding level is properly compacted to true lines and level.
- (c) All concrete and other elements are laid in dry bed.

20.1.2.2. **Rigid flooring** : The rigid flooring should be provided under the bridge and it should extend for a distance of at least 3 m on upstream side and 5 m on down stream side of the bridge. However, in case the splayed wing walls of the structure are likely to be longer, the flooring should extend upto the line connecting the end of wing walls on either side of the bridge.

The top of flooring should be kept 300 mm below the lowest bed level.

Flooring should consist of 150 mm thick flat stone/bricks on edge in cement mortar 1:3 laid over 300 mm thick cement concrete M15 grade laid over a layer of 150 mm thick cement concrete M10 grade. Joints at suitable spacings (say 20 m) may be provided.

20.1.2.3. **Curtain walls** : The rigid flooring should be enclosed by curtain walls (tied to the wing walls) with a minimum depth below floor level of 2 m on upstream side and 2.5 m on downstream side. The curtain wall should be in cement concrete M15 grade or brick/stone masonry in cement mortar 1:3. The rigid flooring should be continued over the top width of curtain walls. In this context,

relevant provision in “Guidelines for design and construction of river training and control works for road bridges”, IRC: 89-1997 is also referred.

20.1.2.4. **Flexible apron :** Flexible apron 1 m thick comprising of loose stone boulders (weighing not less than 40 kg) should be provided beyond the curtain walls for a minimum distance of 3 m on upstream side and 6 m on downstream side. Where required size stones are not economically available, cement concrete blocks or stones in wire crates may be used in place of isolated stones. In this context, relevant provision in IRC:89-1997 is also referred.

20.1.2.5. Wherever scour is restricted by provision of flooring/flexible apron, the work of flooring/apron etc., should be simultaneously completed along with the work on foundations so that the foundation work completed is not endangered.

20.2. Maintenance :

20.2.1. The bridge structures are more susceptible to damages during monsoon. It is generally observed that following factors contribute mainly to damage.

- (a) Choking of vents
- (b) Wash outs of approaches
- (c) Dislodgement of wearing course and cushion
- (d) Scour on D/S (downstream)
- (e) Silting on U/S (upstream)
- (f) Collection of debris on approaches in cutting

20.2.2. To minimize the occurrence of above phenomena, it is necessary to take adequate steps as below:

- (1) The vents should be thoroughly cleaned before every monsoon.
- (2) The bridge vents should be cleared after the first monsoon flood as the flood carries maximum debris with it.
- (3) Keep approaches almost matching with existing bank, i.e., cutting or embankment should be minimum to avoid wash outs of approaches.
- (4) Disposal of water through side gutters shall be properly planned so that it does not damage the cross-drainage work proper.
- (5) The wearing coat with cushion should be sufficiently stable and it should not get dislodged during floods.
- (6) In the event of approaches being in cutting there is a tendency of whirling of water at the approaches. This leads to collection of debris in the approaches. After the floods recede, huge heap of debris is found on the approaches. This should be quickly cleared.

ARTICLE 21

RAFT FOUNDATIONS

21.1. Raft foundation is preferred when the good foundable strata is not available within a reasonable depth. Thus, the sandy layer or sand and silty foundations warrant provision of raft foundation. While providing raft foundation, some important points should be kept in view.

21.1.1. Raft top should be kept 300 mm below the lowest bed level. This will ensure protection to raft and also would avoid silting tendency on U/S and scouring tendency on D/S. The raft will also not be subjected to stresses due to temperature variations.

21.1.2. U/S and D/S aprons should be provided to protect the bridge from scouring or undermining. The width of U/S and D/S aprons should be $1.5 d_{sm}$ and $2.0 d_{sm}$ respectively (Fig. 21.1).

21.1.3. The depth of cut-off wall should be 30 cm below the scour level. The normal scour depth is worked out by the formula $d_{sm} = 1.34 \times \left(\frac{D_b^2}{K_{sf}} \right)^{1/3}$ (Refer Equation 9.1).

(Scour Depth need not be increased by any factor as in case of open foundations as stipulated in IRC:78-2000).

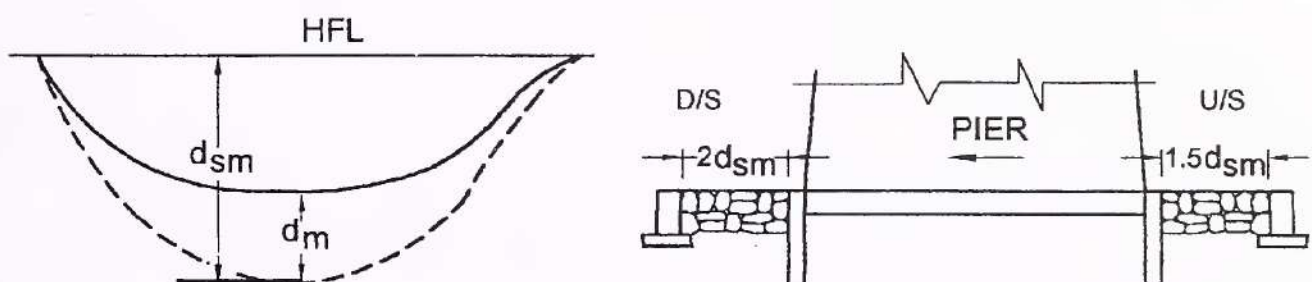

Fig. 21.1 Scour Depth and Apron Width for Raft

21.1.4. Longitudinal cut-off walls should be provided on U/S and D/S side and they should be connected by cross cut off walls. Longitudinal cut-off walls safeguard the bridge from scour where as the cross-cut-off walls keep the longitudinal cut-off walls in position and also protect the bridge from scouring particularly due to out flanking.

21.1.5. The raft is generally as wide as the deck but in certain cases may be narrower than the deck (Fig. 21.2).

21.1.6. Pressure relief holes may be provided in the raft to relieve the raft from possible uplift pressure from below. The holes need to be carefully packed with graded filter material to prevent outflow of soil particles of the foundation strata alongwith the flow of water (Fig. 21.3).

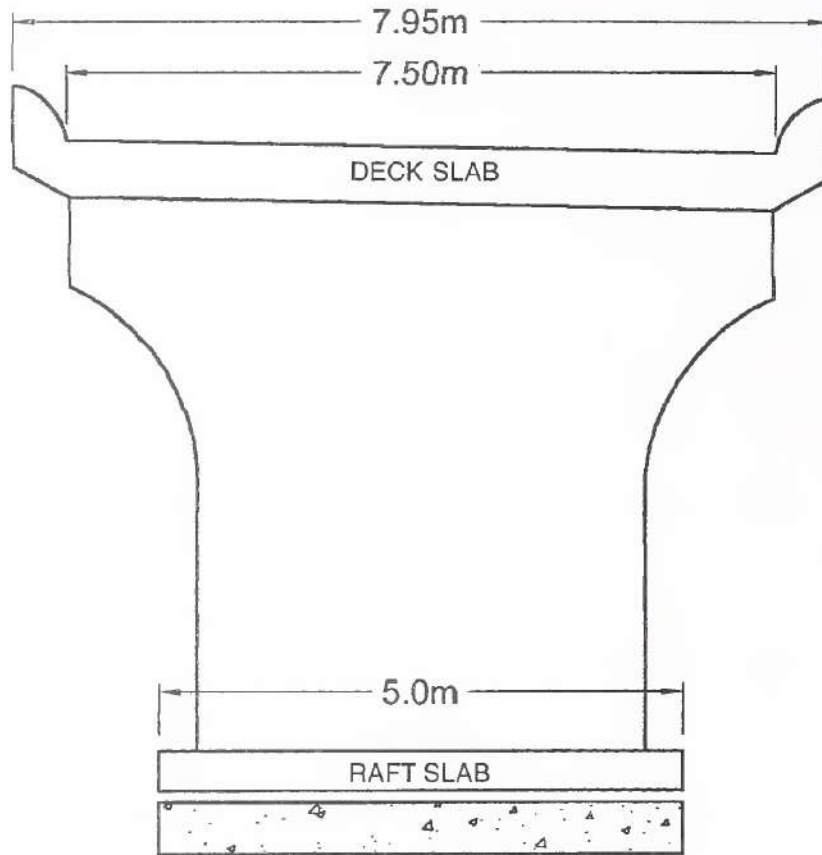

Fig. 21.2 Raft Slab Narrower than Deck Width

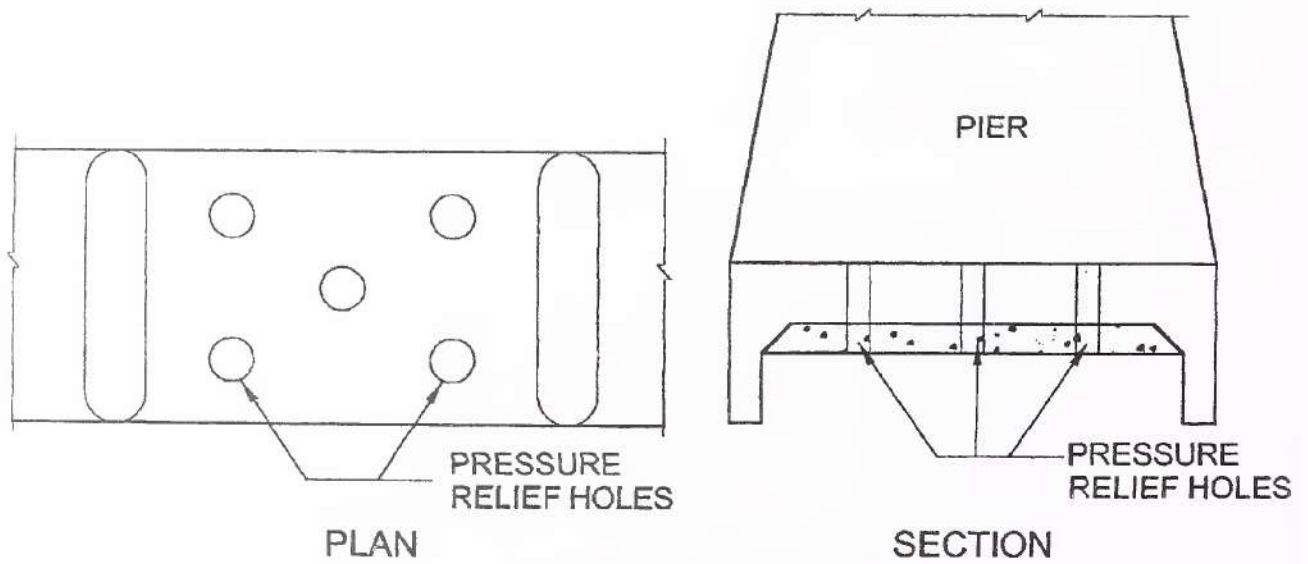

Fig. 21.3 Pressure Relief Holes in Raft Slab

ARTICLE 22

C.D. WORKS IN BLACK COTTON SOILS

22.1. Generally, the black cotton (B.C.) soil is of expansive nature. As it comes in contact with water, the montmorillonite group cells expand. This phenomenon leads to heavy pressure on structure and the structure may develop cracks and fail. It is, therefore, necessary to safeguard the structure from the ill-effects of the damaging nature of the soil. It is desirable to cut the contact of expansive soil and the foundation structure. This can be achieved by providing a sandy media all around the foundation. Such non-expansive layer not only cuts the all around contact between soil and foundation but also absorbs energy of swelling and shrinking of foundation soil below the layer of sand and keeps the foundation safe.

22.2. The expansive soils have very poor bearing capacity. The same needs improvement, which can be done by providing layer of metal/boulder with sand having thickness of about 450 to 600 mm. Such layer, improves Safe Bearing Capacity (SBC) of the strata to a considerable extent and safeguards the foundation from the adverse effects of the expansive soil also (Fig. 22.1).

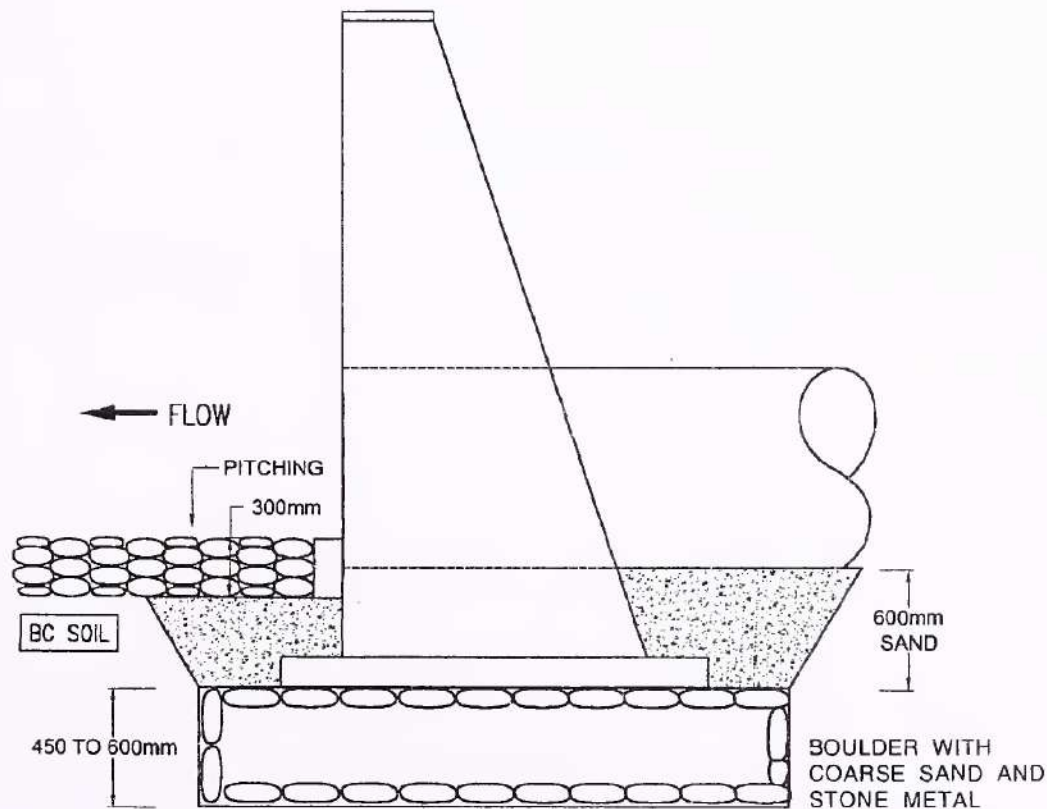

Fig. 22.1 Hume Pipe Culvert in BC Soil

ARTICLE 23

BOX CELL STRUCTURES

23.1. **Where to Provide Box Structures :** Box structures are hydraulically efficient structures where thickness of walls and slab are small and there is least obstruction to flow.

When the river or Nalla has sandy bed and/or purely clayey strata, the independent foundations are likely to be deeper and this may enhance the cost of culverts and small bridges. Under these circumstances box culverts are found to be a better solution. Several such box cell structures have shown a good in service performance. Purely sandy soil or clayey strata may be at few places but mixed soils are available in several cases. Where ϕ value of mixed soil is less than 15° , it may be treated as a clayey soil. Similarly, where safe bearing capacity of soil is found to be less than 10 t/m^2 , box culverts are most suitable for such type of soils.

23.2. **Type of Boxes :** Box cell structures with and without earth cushion based on MORT&H Standard Drawings are given in 10 plates as brought out in para 14.5.

23.3. **Foundation :** Where there is purely clayey strata top 900 mm below box should have granular material, like, sandy murum or stone dust.

Where there is murum and mixed soil having ϕ more than 15° , there is no need of providing sandy layer.

The box cell structures are of concrete of M 20 grade for moderate and M 25 grade for severe conditions of exposure with HYSD steel bars.

Box cell structures are to be provided with curtain walls and apron and these must be completed before floods. The best practice is to lay foundations of curtain wall and apron first and then lay box.

200

SITE CLEARANCE

201 CLEARING AND GRUBBING

Scope

This work shall consist of cutting, removing and disposing of all materials such as trees, bushes, shrubs, stumps, roots, grass, weeds, rubbish, top organic soil, etc. to an average depth of 150 mm in thickness, which in the opinion of the Engineer are unsuitable for incorporation in the works, from the area of road land containing road embankment, drains, cross-drainage structures and such other areas as may be specified on the drawings or by the Engineer. It shall include necessary excavation, backfilling of pits resulting from uprooting of trees and stumps to required compaction, handling, salvaging, and disposal of cleared materials with all leads and lifts. Clearing and grubbing shall be performed in advance of earthwork operations and in accordance with the requirements of these Specifications.

Preservation of Property/Amenities

Roadside trees, shrubs, any other plants, pole lines, fences, signs, monuments, buildings, pipelines, sewers and all highway facilities within or adjacent to the highway which are not to be disturbed shall be protected from injury or damage. The Contractor shall provide and install at his own cost, suitable safeguards approved by the Engineer for this purpose.

During clearing and grubbing, the Contractor shall take all adequate precautions against soil erosion, water pollution, etc., and where required, undertake additional works to that effect vide Clause 306. Before start of operations, the Contractor shall submit to the Engineer for approval, his work plan including the procedure to be followed for disposal of waste materials, etc., and the schedules for carrying out temporary and permanent erosion control works as stipulated in Clause 306.3.

Methods, Tools and Equipment

Only such methods, tools and equipment as are approved by the Engineer and which will not affect any property to be preserved shall be adopted for the Work. If the area has thick vegetation/roots/trees, a crawler or pneumatic tyred dozer of adequate capacity may be used for clearance purposes. The dozer shall have ripper attachments for removal of tree stumps. All trees, stumps, etc., falling within excavation and fill lines shall be cut to such depth belowground level that in no case these fall within 500 mm of the bottom of the subgrade. Also, all vegetation such as roots, under-growth, grass and other deleterious matter unsuitable for incorporation in the embankment/subgrade shall be removed between fill lines to the satisfaction of the Engineer. All branches of trees extending above the roadway shall be trimmed as directed by the Engineer.

All excavations below the general ground level arising out of the removal of trees, stumps, etc., shall be filled with suitable material and compacted thoroughly so as to make the surface at these points conform to the surrounding area.

Ant-hills both above and below the ground, as are liable to collapse and obstruct free subsoil water flow shall be removed and their workings, which may extend to several metres, shall be suitably treated.

Disposal of Materials

All materials arising from clearing and grubbing operations shall be taken over and shall be disposed of by the Contractor at suitable disposal sites with all leads and lifts. The disposal shall be in accordance with local, State and Central regulations

Measurements for Payment

Clearing and grubbing for road embankment, drains and cross-drainage structures shall be measured on area basis in terms of hectares. Cutting of trees upto 300 mm in girth and removal of their stumps, including removal of stumps upto 300 mm in girth left over after trees have been cut by any other agency, and trimming of branches of trees extending above the roadway and backfilling to the required compaction shall be considered incidental to the clearing and grubbing operations. Clearing and grubbing of borrow areas shall be deemed to be a part of works preparatory to embankment construction and shall be deemed to have been included in the rates quoted for the embankment construction item and no separate payment shall be made for the same.

Ground levels shall be taken prior to and after clearing and grubbing. Levels taken prior to clearing and grubbing shall be the base level and will be accordingly used for assessing the depth of clearing and grubbing and computation of quantity of any unsuitable material which is required to be removed.

The levels taken subsequent to clearing and grubbing shall be the base level for computation of earthwork for embankment.

Cutting of trees, excluding removal of stumps and roots of trees of girth above 300 mm shall be measured in terms of number according to the girth sizes given below :-

- i) Above 300 mm to 600 mm
- ii) Above 600 mm to 900 mm
- iii) Above 900 mm to 1800 mm
- iv) Above 1800 mm

Removal of stumps and roots including backfilling with suitable material to required compaction shall be a separate item and shall be measured in terms of number according to the sizes given below:-

- i) Above 300 mm to 600 mm
- ii) Above 600 mm to 900 mm
- iii) Above 900 mm to 1800 mm
- iv) Above 1800 mm

For the purpose of cutting of trees and removal of roots and stumps, the girth shall be measured at a height of 1 m above ground or at the top of the stump if the height of the stump is less than one metre from the ground.

Rates

The Contract unit rates for the various items of clearing and grubbing shall be payment in full for carrying out the required operations including full compensation for all labour, materials, tools, equipment and incidentals necessary to complete the work. These will also include removal of stumps of trees less than 300 mm girth excavation and back-filling to required density, where necessary, and handling, giving credit towards salvage value disposing of the cleared materials with all lifts and leads. Clearing and grubbing done in excess of 150 mm by the Contractor shall be made good by the Contractor at his own cost as per Clause 301.3.3 to the satisfaction of the Engineer prior to taking up earthwork. Where clearing and grubbing is to be done to a level beyond 150 mm, due to site considerations, as directed by the Engineer, the extra quantity shall be measured and paid separately.

The Contract unit rate for cutting trees of girth above 300 mm shall include handling, giving credit towards salvage value disposing of the cleared materials with all lifts and leads.

The Contract unit rate for removal of stumps and roots of trees girth above 300 mm shall include excavation and backfilling with suitable material to required compaction, handling, giving credit towards salvage value disposing of the cleared materials with all lifts and leads.

The Contract unit rate is deemed to include credit towards value of usable materials, salvage

value of unusable materials and off-set price of cut trees and stumps belonging to the Forest Department. The off-set price of cut trees and stumps belonging to the Forest Department shall be deducted from the amount due to the Contractor and deposited with the State Forest Department. In case the cut trees and stumps are required to be deposited with the Forest Department the Contractor shall do so and no deduction towards the off-set price shall be effected. The offset price shall be as per guidelines / estimates of the State Forest Department.

Where a Contract does not include separate items of clearing and grubbing, the same shall be considered incidental to the earthwork items and the Contract unit prices for the same shall be considered as including clearing and grubbing operations.

202 DISMANTLING CULVERTS, BRIDGES AND OTHER STRUCTURES/PAVEMENTS

Scope

This work shall consist of dismantling and removing existing culverts, bridges, pavements, kerbs and other structures like guard-rails, fences, utility services, manholes, catch basins, inlets, etc., from the right of way which in the opinion of the Engineer interfere with the construction of road or are not suitable to remain in place, disposing of the surplus/unsuitable materials and backfilling to after the required compaction as directed by the Engineer.

Existing culverts, bridges, pavements and other structures which are within the highway and which are designated for removal, shall be removed upto the limit and extent specified in the drawings or as indicated by the Engineer.

Dismantling and removal operations shall be carried out with such equipment and in such a manner as to leave undisturbed, adjacent pavement, structures and any other work to be left in place.

All operations necessary for the removal of any existing structure which might endanger new construction shall be completed prior to the start of new work.

Dismantling Culverts and Bridges

The structures shall be dismantled carefully and the resulting materials so removed as not to cause any damage to the part of the structure to be retained and any other properties or structures nearby.

Unless otherwise specified, the superstructure portion of culverts/bridges shall be entirely removed and other parts removed up to at least 600 mm below the sub-grade, slope face or original ground level whichever is the lowest or as necessary depending upon the interference they cause to the new

construction. Removal of overlying or adjacent material, if required in connection with the dismantling of the structures, shall be incidental to this item.

Where existing culverts/bridges are to be extended or otherwise incorporated in the new work, only such part or parts of the existing structure shall be removed as are necessary and directed by the Engineer to provide a proper connection with the new work. The connecting edges shall be cut, chipped and trimmed to the required lines and grades without weakening or damaging any part of the structure to be retained. Due care should be taken to ensure that reinforcing bars which are to be left in place so as to project into the new work as dowels or ties are not injured during removal of concrete.

Pipe culverts shall be carefully removed in such a manner as to avoid damage to the pipes. Steel structures shall, unless otherwise provided, be carefully dismantled in such a manner as to avoid damage to members thereof. If specified in the drawings or directed by the Engineer that the structure is to be removed in a condition suitable for re-erection, all members shall be match-marked by the Contractor with white lead paint before dismantling; end pins, nuts, loose plates, etc. shall be similarly marked to indicate their proper location; all pins, pin holes and machined surfaces shall be painted with a mixture of white lead and tallow and all loose parts shall be securely wired to adjacent members or packed in boxes.

Timber structures shall be removed in such a manner as to avoid damage to such timber or lumber having salvage value as is designated by the Engineer.

Dismantling Pavements and Other Structures

In removing pavements, kerbs, gutters, and other structures like guard-rails, fences, manholes, catch basins, inlets, etc., where portions of the existing construction are to be left in the finished work, the same shall be removed to an existing joint or cut and chipped to a true line with a face perpendicular to the surface of the existing structure. Sufficient removal shall be made to provide for proper grades and connections with the new work as directed by the Engineer.

All concrete pavements, base courses in carriageway and shoulders etc., designated for removal shall be broken to pieces whose volume shall not exceed 0.02 cu.m and used with the approval of the Engineer or disposed of.

Back-filling

Holes and depressions caused by dismantling operations shall be backfilled with excavated or other approved materials and compacted to required density as directed by the Engineer.

Disposal of Materials

All surplus materials shall be taken over by the Contractor which may either be re-used with the approval of the Engineer or disposed of with all leads and lifts.

Measurements for Payment

The work of dismantling shall be paid for in units indicated below by taking measurements before and after, as applicable:

i)	Dismantling brick/stone masonry/ concrete (plain and reinforced)	cu.m
ii)	Dismantling flexible and cement concrete pavement	cu.m
iii)	Dismantling steel structures	tonne
iv)	Dismantling timber structures	cu.m
v)	Dismantling pipes, guard rails, kerbs, gutters and fencing	linear m
vi)	Utility services	No.

Rates

The Contract unit rates for the various items of dismantling shall be paid in full for carrying out the required operations including full compensation for all labour, materials, tools, equipment, safeguards and incidentals necessary to complete the work. The rates will include excavation and backfilling to the required compaction and for handling, giving credit towards salvage value disposing of dismantled materials with all lifts and leads.

300

**EARTHWORK, EROSION
CONTROL AND
DRAINAGE**

301 EXCAVATION FOR ROADWAY AND DRAINS

Scope

This work shall consist of excavation, removal and disposal of materials necessary for the construction of roadway, side drains and waterways in accordance with requirements of these Specifications and the lines, grades and cross-sections shown in the drawings or as indicated by the Engineer. It shall include the hauling and stacking of or hauling to sites of embankment and subgrade construction suitable cut materials as required, as also the disposal of unsuitable cut materials in specified manner, with all leads and lifts, reuse of cut materials as may be deemed fit, trimming and finishing of the road to specified dimensions or as directed by the Engineer.

Classification of Excavated Material

Classification : All materials involved in excavation shall be classified by the Engineer in the following manner:

a) Soil :

This shall comprise topsoil, turf, sand, silt, loam, clay, mud, peat, black-cotton soil, soft shale or loose moorum, a mixture of these and similar material which yields to the ordinary application of pick, spade and/or shovel, rake or other ordinary digging equipment. Removal of gravel or any other modular material having dimension in any one direction not exceeding 75 mm shall be deemed to be covered under this category.

b) Ordinary Rock (not requiring blasting) This shall include :

i) rock types such as laterites, shales and conglomerates, varieties of limestone and sandstone etc., which may be quarried or split with crow bars, also including any rock which in dry state may be hard, requiring blasting but which, when wet, becomes soft and manageable by means other than blasting;

ii) macadam surfaces such as water bound and bitumen bound; soling of roads, cement concrete pavement, cobble stone, etc. compacted moorum or stabilized soil requiring use of pick axe or shovel or both.

iii) lime concrete, stone masonry and brick work in lime/cement mortar below ground level, reinforced cement concrete which may be broken up with crow bars or picks and stone masonry in cement mortar below ground level; and

iv) boulders which do not require blasting found lying loose on the surface or embedded in river bed, soil, talus, slope wash and terrace material of dissimilar origin.

c) Hard Rock (requiring blasting)

This shall comprise :

- i) any rock or cement concrete for the excavation of which the use of mechanical plant and/or blasting is required,
- ii) reinforced cement concrete below ground level and in bridge/ROB/RUB/flyover piers and abutments,
- iii) boulders requiring blasting.

d) Hard Rock (using controlled blasting) :

Hard rock requiring blasting as described under (c) but where controlled blasting is to be carried out in locations where built-up area, huts, and are situated at within 200 m of the blast site.

e) Hard Rock (blasting prohibited)

Hard rock requiring blasting as described under (d) but where blasting is prohibited for any reason like people living within 20 m of blast site etc. and excavation has to be carried out by chiselling, wedging or any other agreed method.

f) Marshy soil

This shall include soils like soft clays and peats excavated below the original ground level of marshes and swamps and soils excavated from other areas requiring continuous pumping or bailing out of water.

Authority for Classification

The classification of excavation shall be decided by the Engineer and his decision shall be final and binding on the Contractor. Merely the use of explosives in excavation will not be considered as a reason for higher classification unless blasting is clearly necessary in the opinion of the Engineer.

Construction Operations Setting Out

After the site has been cleared as per Clause 201, the limits of excavation shall be set out true to lines, curves, slopes, grades and sections as shown on the drawings or as directed by the Engineer. Clause 109 shall be applicable for the setting out operations.

Stripping and Storing Topsoil

When so directed by the Engineer, the topsoil existing over the sites of excavation shall be

stripped to specified depths and stockpiled at designated locations for re-use in covering embankment slopes, cut slopes, berms and other disturbed areas where re-vegetation is desired in accordance with Clause 305.3.3. Prior to stripping the topsoil, all trees, shrubs etc. shall be removed along with their roots, with approval of the Engineer.

Excavation–General

All excavations shall be carried out in conformity with the directions laid here-in-under and in a manner approved by the Engineer. The work shall be so done that the suitable materials available from excavation are satisfactorily utilized as deemed fit or as approved by the Engineer.

While planning or executing excavations, the Contractor shall take all adequate precautions against soil erosion, water pollution etc. as per Clause 306, and take appropriate drainage measures to keep the site free of water in accordance with Clause 311.

The excavations shall conform to the lines, grades, side slopes and levels shown on the drawings or as directed by the Engineer. The Contractor shall not excavate outside the limits of excavation. Subject to the permitted tolerances, any excess depth/width excavated beyond the specified levels/dimensions on the drawings shall be made good at the cost of the Contractor with suitable material of characteristics similar to that removed and compacted to the requirements of Clause 305.

All debris and loose material on the slopes of cuttings shall be removed. No backfilling shall be allowed to obtain required slopes excepting that when boulders or soft materials are encountered in cut slopes, these shall be excavated to approved depth on instructions of the Engineer and the resulting cavities filled with suitable material and thoroughly compacted in an appropriate manner.

After excavation, the sides of excavated area shall be trimmed and the area contoured to minimize erosion and ponding, allowing for natural drainage to take place.

Methods, Tools and Equipment

Only such methods, tools and equipment as approved by the Engineer shall be adopted/ used in the work. If so desired by the Engineer, the Contractor shall demonstrate the efficacy of the type of equipment to be used before the commencement of work.

Rock Excavation

Rock, when encountered in road excavation, shall be removed upto the formation level or as otherwise indicated in the drawings. Where, however, unstable shales or other unsuitable materials are encountered at the formation level, these shall be excavated to the extent of 500 mm below the formation level or as otherwise specified. In all cases, the excavation operations shall be so carried out that at no point on cut formations the rock protrudes above the specified levels. Rocks and boulders which are likely to cause differential settlement and also local drainage problems shall be removed to the extent of 500 mm below the formation level in the formation width including side drains.

Where excavation is done to levels lower than those specified, the excess excavation shall be made good as per Clauses 301.3.3 and 301.6 to the satisfaction of the Engineer.

Slopes in rock cutting shall be finished to uniform lines corresponding to slope lines shown on the drawings or as directed by the Engineer. Notwithstanding the foregoing, all loose pieces of rock on excavated slope surface which move when pierced by a crowbar shall be removed.

Where blasting is to be resorted to, the same shall be carried out as per Clause 302 and all precautions indicated therein observed.

Where presplitting is prescribed to be done for the establishment of a specified slope in rock excavation, the same shall be carried out as per Clause 303.

Marsh Excavation

The excavation of soil from marshes/swamps shall be carried out as per the programme approved by the Engineer.

Excavation of marshes shall begin at one end and proceed in one direction across the entire marsh immediately ahead of backfilling with materials like boulders, sand moorum, bricks bats, dismantled concrete as approved by the Engineer. The method and sequence of excavating and backfilling shall be such as to ensure, to the extent practicable, the complete removal or displacement of all muck from within the lateral limits indicated on the drawings or as staked by the Engineer.

Excavation of Road Shoulders/Verge/Median for Widening of Pavement or Providing Treated Shoulders

In the works involving widening of existing pavements or providing paved shoulders, the existing shoulders/verge/median shall be removed to its full width and upto top of the subgrade. The subgrade material within 500 mm from the bottom of the pavement for the widened portion or paved shoulders shall be loosened and recompacted as per Clause 305. Any unsuitable material found in this portion shall be removed and replaced with the suitable material. While doing so, care shall be taken to see that no portion of the existing pavement designated for retention is loosened or disturbed. If the existing pavement gets disturbed or loosened, it shall be dismantled and cut to a regular shape with sides vertical and the disturbed/loosened portion removed completely and relaid as directed by the Engineer, at the cost of the Contractor.

Excavation for Surface/Sub-Surface Drains

Where the Contract provides for construction of surface/sub-surface drains, the same shall be done as per Clause 309. Excavation for these drains shall be carried out in proper sequence with other works as approved by the Engineer.

Slides

If slips, slides, over-breaks or subsidence occur in cuttings during the process of construction, they shall be removed at the cost of the Contractor as ordered by the Engineer. Adequate precautions shall be taken to ensure that during construction, the slopes are not rendered unstable or give rise to recurrent slides after construction. If finished slopes slide into the roadway subsequently, such slides shall be removed and paid for at the Contract rate for the class of excavation involved, provided the slides are not due to any negligence on the part of the Contractor. The classification of the debris material from the slips, slides etc. shall conform to its condition at the time of removal and payment made accordingly regardless of its condition earlier.

Dewatering

If water is met with in the excavations due to springs, seepage, rain or other causes, it shall be removed by suitable diversions, pumping or bailing out and the excavation kept dry whenever so required or directed by the Engineer. Care shall be taken to discharge the drained water into suitable outlets as not to cause damage to the works, crops or any other property. Due to any negligence on the part of the Contractor, if any such damage is caused, it shall be the sole responsibility of the Contractor to repair/restore to the original condition at his own cost or compensate for the damage.

Use and Disposal of Excavated Materials

All the excavated materials shall either be reused with the approval of the Engineer or disposed off with all loads and lifts as directed by the Engineer.

Backfilling

Backfilling of masonry/concrete hume pipe or drain excavation shall be done with approved material with all loads and lifts after concrete/masonry/hume pipe is fully set and carried out in such a way as not to cause undue thrust on any part of the structure and/or not to cause differential settlement. All space between the drain walls and the side of the excavation shall be backfilled to the original surface making due allowance for settlement, in layers not exceeding 150 mm compacted thickness to the required density, using suitable compaction equipment such as trench compactor, mechanical tamper, rammer or plate compactor as directed by the Engineer.

Plying of Construction Traffic

Construction traffic shall not use the cut formation and finished subgrade without the prior permission of the Engineer. Any damage arising out of such use shall be made good by the Contractor at his own cost.

Preservation of Property

The Contractor shall undertake all reasonable precautions for the protection and preservation of any or all existing roadside trees, drains, sewers, sub-surface drains, pipes, conduits and any other structures under or above ground, which may be affected by construction operations and which, in the opinion of the Engineer, shall be continued in use without any change. Safety measures taken by the Contractor in this respect, shall be got approved from the Engineer. However, if any, of these objects is damaged by reason of the Contractor's negligence, it shall be replaced or restored to the original condition at his cost. If the Contractor fails to do so, within the required time as directed by the Engineer or if, in the opinion of the Engineer, the actions initiated by the Contractor to replace/restore the damaged objects are not satisfactory, the Engineer shall arrange the replacement/restoration directly through any other agency at the risk and cost of the Contractor after issuing prior notice to the effect.

Preparation of Cut Formation

The cut formation, which serves as a sub-grade, shall be prepared to receive the sub-base/base course as directed by the Engineer.

Where the material in the subgrade has a density less than specified in Table 300-1, the same shall be loosened to a depth of 500 mm and compacted in layers in accordance with the requirements of Clause 305 adding fresh material, if any required, to maintain the formation level as shown on the drawings. Any unsuitable material encountered in the subgrade level shall be removed as directed by the Engineer, replaced with suitable material and compacted in accordance with Clause 305.

In rocky formations, the surface irregularities shall be corrected and the levels brought up to the specified elevation with granular base material as directed by the Engineer, laid and compacted in accordance with the respective Specifications for these materials. The unsuitable material shall be disposed of in accordance with Clause 301.3.11. After satisfying the density requirements, the cut formation shall be prepared to receive the sub-base/base course in accordance with Clauses 310 and 311.

Finishing Operations

Finishing operations shall include the work of properly shaping and dressing all excavated surfaces.

When completed, no point on the slopes shall vary from the designated slopes by more than 150 mm measured at right angles to the slope, except where excavation is in rock (ordinary or hard) where no point shall vary more than 300 mm from the designated slope. In no case shall any portion of the slope encroach on the roadway.

The finished cut formation shall satisfy the surface tolerances described in Clause 902. Where directed, the topsoil removed and conserved (Clauses 301.3.2 and 305.3.3) shall be spread over cut slopes, shoulders and other disturbed areas. Slopes may be roughened and moistened slightly, prior to the application of topsoil, in order to provide satisfactory bond. The depth of topsoil shall be sufficient to sustain plant growth, the usual thickness being from 75 mm to 100 mm.

Measurements for Payment

Excavation for roadway shall be measured by taking cross-sections at suitable intervals before the excavation starts (after clearing and grubbing/stripping etc. as the case may be) and after its completion and computing the volumes in cu.m by the method of average end areas for each class of material encountered. Where it is not feasible to compute volumes by this method because of erratic location of isolated deposits, the volumes shall be computed by other accepted methods.

At the option of the Engineer, the Contractor shall leave depth indicators during excavations of such shape and size and in such positions as directed so as to indicate the original ground level as accurately as possible. The Contractor shall see that these remain intact till the final measurements are taken.

For rock excavation, the overburden shall be removed first so that necessary cross-sections could be taken for measurement. Where cross-sectional measurements could not be taken due to irregular configuration or where the rock is admixed with other classes of materials, the volumes shall be computed on the basis of measurement of stacks of excavated rubble allowing a deduction of 35% therefrom. When volume is calculated on the basis of measurement of stacks of the excavated material other than rock, a deduction of 16% of stacked volume shall be allowed.

Works involved in the preparation of cut formation shall be measured in units indicated below:

i)	Loosening and recompacting the loosened material at subgrade	...cu.m
ii)	Loosening and removal of unsuitable material and replacing with suitable material and compacting to required density	...cu.m
iii)	Preparing rocky subgrade	...sq.m
iv)	Stripping including storing and reapplication of topsoil	...cu.m

Rates

The Contract unit rates for the items of roadway and drain excavation shall be payment in full for carrying out the operations required for the individual items including full compensation for:

- i) setting out;
- ii) transporting the excavated materials for use or disposal with all leads and lifts by giving suitable credit towards the cost of re-usable material and salvage value of unusable material;
- iii) trimming bottoms and slopes of excavation;
- iv) dewatering;
- v) keeping the work free of water as per Clause 311;
- vi) arranging disposal sites; and
- vii) all labour, materials, tools, equipment., safety measures, testing and incidentals necessary to complete the work to Specifications.

Where presplitting of rock is prescribed it shall be governed by Clause 303.5.

The Contract unit rate for loosening and recompacting the loosened materials at subgrade shall include full compensation for loosening to the specified depth, including breaking clods, spreading in layers, watering where necessary and compacting to the requirements.

Clauses 301.9.1 and 305.8 shall apply as regards Contract unit rate for item of removal of unsuitable material and replacement with suitable material respectively.

The Contract unit rate for item of preparing rocky sub-grade as per Clause 301.6 shall be full compensation for providing, laying and compacting granular base material for correcting surface irregularities including all materials, labour and incidentals necessary to complete the work and all leads and lifts.

The Contract unit rate for the items of stripping and storing topsoil and of reapplication of topsoil shall include full compensation for all the necessary operations including all lifts and leads.

302 BLASTING OPERATIONS

General

Blasting shall be carried out in a manner that completes the excavation to the lines indicated in drawings, with the least disturbance to adjacent material. It shall be done only with the written permission of the Engineer. All the statutory laws, regulations, rules, etc., pertaining to the acquisition, transportation, storage, handling and use of explosives shall be strictly followed by the contractor.

The Contractor may adopt any method or methods of blasting consistent with the safety and job requirements. Prior to starting any phase of the operation, the Contractor shall provide information describing pertinent blasting procedures, dimensions and notes.

The magazine for the storage of explosives shall be built to the designs and specifications of the Explosives Department concerned and located at the approved site. The storage place shall be clearly marked "DANGER-EXPLOSIVES". The Contractor shall be liable for property damage, injury or death resulting from the use of explosives. All permits shall be obtained by the Contractor. No unauthorized person shall be admitted into the magazine which, when not in use, shall be kept securely locked. No matches or inflammable material shall be allowed in the magazine. The magazine shall have an effective lightning conductor. The following shall be hung in the lobby of the magazine:

- a) A copy of the relevant rules regarding safe storage both in English and in the language with which the workers concerned are familiar,

- b) A statement of up-to-date stock in the magazine,
- c) A certificate showing the last date of testing of the lightning conductor,
and
- d) A notice that smoking is strictly prohibited.

All explosives shall be stored in a secure manner in compliance with all laws and ordinances, and all such storage places shall be marked. Where no local laws or ordinances apply, storage shall be provided to the satisfaction of the Engineer and in general not closer than 300 m from the road or from any building or camping area or place of human occupancy. In addition to these, the Contractor shall also observe the following instructions and any further additional instructions which may be given by the Engineer and shall be responsible for damage to property and any accident which may occur to workmen or public on account of any operations connected with the storage, handling or use of explosives and blasting. The Engineer shall frequently check the Contractor's compliance with these precautions.

Materials, Tools and Equipment

All the materials, tools and equipment used for blasting operations shall be of approved type. The Engineer may specify the type of explosives to be allowed in special cases. The fuse to be used in wet locations shall be sufficiently water-resistant as to be unaffected when immersed in water for 30 minutes. The rate of burning of the fuse shall be uniform and definitely known to permit such a length being cut as will permit sufficient time to the firer to reach safely before explosion takes place. Detonators shall be capable of giving effective blasting of the explosives. The blasting powder, explosives, detonators, fuses, etc., shall be fresh and not damaged due to dampness, moisture or any other cause. They shall be inspected before use and damaged articles shall be discarded totally and removed from the site immediately.

Personnel

The blasting operation shall remain in the charge of competent and experienced supervisor and workmen who are thoroughly acquainted with the details of handling explosives and blasting operations.

Blasting Operations

The blasting shall be carried out during the pre-determined hours of the day preferably during the mid-day luncheon hour or at the close of the work as ordered in writing by the Engineer. The hours shall be made known to the people in the vicinity.

The Contractor shall notify each public utility company having structures in proximity to the site of the work of his intention to use explosives. Such notice shall be given sufficiently in advance to

enable the companies to take such steps as they may deem necessary to protect their property from injury. In advance of any blasting work within 50 m of any railway track or structures, the Contractor shall notify the concerned Railway Authority of the location, date, time and approximate duration of such blasting operation.

Red danger flags shall be displayed prominently in all directions during the blasting operations. The flags shall be planted 200 m from the blasting site in all directions. People, except those who actually light the fuse, shall be prohibited from entering this area and all persons including workmen shall be kept away from the flagged area, and all persons including workmen shall be removed from the flagged area at least 10 minutes before the firing. A warning siren shall be sounded for the above purpose.

Only controlled blasting shall be resorted to along with the safeguard above at locations where built-up area, huts and structures in use lie within 200 m. Similarly excavation of hard rock without blasting is mandatory where people live within 20 m of blast site.

The charge holes shall be drilled to required depths and at suitable places. Blasting should be as light as possible consistent with thorough breakage of the material necessary for economic loading and hauling. Any method of blasting which leads to overshooting shall be discontinued.

When blasting is done with powder, the fuse cut to the required length shall be inserted into the hole and the powder dropped shall be gently tamped with copper rods with rounded ends. The explosive powder shall then be covered with tamping material which shall be tamped lightly but firmly.

When blasting is done with dynamite and other high explosives, dynamite cartridges shall be prepared by inserting the square cut end of a fuse into the detonator and finishing it with nippers at the open end, the detonator gently pushed into the primer leaving 1/3rd of the copper tube exposed outside. The paper of the cartridge shall then be closed up and securely bound with wire or twine. The primer shall be housed into the explosive. Boreholes shall be cleared of all debris and explosives inserted. The space of about 200 mm above the charge shall then be gently filled with dry clay, pressed home and the rest of the tamping formed of any convenient material gently packed with a wooden rammer.

At a time not more than 10 such charges will be prepared and fired. The man in charge shall blow a siren in a recognized manner for cautioning the people. All the people shall then be required to move to safe distances. The charges shall be lighted by the man-in-charge only. The man-in-charge shall count the number of explosions. He shall satisfy himself that all the charges have been exploded before allowing the workmen to go back to the work site.

After blasting operation, the Contractor shall compact the loose residual material below subgrade and replace the material removed below subgrade with suitable material.

Misfire

In case of misfire, the following procedure shall be observed:

- i) Sufficient time shall be allowed to account for the delayed blast. The man-in-charge shall inspect all the charges and determine the missed charge.
- ii) If it is the blasting powder charge, it shall be completely flooded with water. A new hole shall be drilled at about 450 mm from the old hole and fired. This should blast the old charge. In case, it does not blast the old charge, the procedure shall be repeated till the old charge is blasted.
- iii) In case of charges of gelignite, dynamite, etc., the man-in-charge shall gently remove the tamping and the primer with the detonator. A fresh detonator and primer shall then be used to blast the charge. Alternatively,

the hole may be cleared of 300 mm of tamping and the direction then ascertained by placing a stick in the hole. Another hole may then be drilled 150 mm away and parallel to it. This hole shall then be charged and fired when the misfired hole should explode at the same time. The man-in-charge shall at once report to the Contractor's office and the Engineer all cases of misfire, the cause of the same and what steps were taken in connection therewith.

If a misfire has been found to be due to defective detonator or dynamite, the whole quantity in the box from which defective article was taken must be sent to the authority directed by the Engineer for inspection to ascertain whether all the remaining materials in the box are also defective.

Account

A careful and day to day account of the explosive shall be maintained by the Contractor in an approved register and manner which shall be open to inspection by the Engineer at all times.

303 PRESPLITTING ROCK EXCAVATION SLOPES

General

Presplitting is defined as the establishment of a specified excavation slope in rock by the controlled use of explosives and blasting accessories in properly aligned and spaced drill holes.

The presplitting technique shall be used for forming rock excavation slopes at locations shown on the drawings or as otherwise decided by the Engineer.

Construction Operations

Prior to starting drilling operations for presplitting, the Contractor shall furnish the Engineer a plan outlining the position of all drill holes, depth of drilling, type of explosives to be used, loading pattern and sequence of firing. The drilling and blasting plan is for record purposes only and will not absolve the Contractor of his responsibility for using proper drilling and blasting procedures. Controlled blasting shall begin with a short test section of a length approved by the Engineer. The test section shall be presplit, production drilled and blasted and sufficient material excavated whereby the Engineer can determine if the Contractor's method have produced an acceptable slope.

All overburden soil and weathered rock along the top of the excavation for a distance of about 5 to 15 m beyond the drilling limits, or to the end of the excavation, as decided by the

Engineer shall be removed before drilling the presplitting holes. Particular care and attention shall be directed to the beginning and end of excavations to ensure complete removal of all overburden soil and weathered rock and to expose fresh rock to an elevation equal to the bottom of the adjacent lift of the presplitting holes being drilled.

Slope holes for presplitting shall be drilled along the line of the planned slope within the specified tolerances. The drill holes shall not be less than 60 mm nor more than 75 mm in diameter. Drilling operations shall be controlled by the use of proper equipment and technique to ensure that no hole shall deviate from the plane of the planned slope by more than 300 mm nor shall any hole deviate from being parallel to an adjacent hole by more than two-third of the planned horizontal spacing between holes.

The length of presplit holes for any individual lift shall not exceed 9 m.

The spacing of presplit holes shall not exceed 900 mm on centres and shall be adjusted to result in a uniform shear face between holes.

Auxiliary drill holes along the presplit line, not loaded or stemmed, may be ordered by the Engineer. Except for spacing, auxiliary drill holes shall conform to the provisions for presplit holes.

The line of production holes shall be placed inside the presplit lines in such a manner as to avoid damage to the presplit face.

If necessary, to reduce shatter and overbreak of the presplit surface, the first line of the production holes shall be drilled parallel to the slope line at the top of the cut and at each bench level thereafter.

Any blasting technique, which results in damage to the presplit surface, shall be immediately discontinued.

No portion of any production holes shall be drilled within 2.5 m of a presplit plane except as approved by the Engineer. The bottom of the production holes shall not be lower than the bottom of the presplit holes.

A maximum offset of 600 mm will be permitted for a construction working bench at the bottom of each lift for use in drilling the next lower presplitting pattern. The drilling operations shall be adjusted to compensate for drift of previous levels and for the offset at the start of new levels to maintain the specified slope plane.

The maximum diameter of explosives used in presplit holes shall not be greater than one-half the diameter of the presplit hole.

Only standard cartridge explosives prepared and packaged by explosive manufacturing firms shall be used in presplit holes. These shall be fired as recommended by the manufacturer. Ammonium nitrate composition blasting agents will not be permitted in presplitting operations.

Stemming may be required to achieve a satisfactory presplit face. Stemming material shall be dry free-running material all of which passes 11.2 mm sieve and 90 percent of which is retained on 2.80 mm sieve. Stemmed presplit holes shall be completely filled to the collar.

All charges in each presplitting pattern shall be detonated simultaneously.

Tolerances

The presplit face shall not deviate more than 300 mm from the plane passing through adjacent drill holes, except where the character of the rock is such that, as determined by the Engineer, irregularities are unavoidable. When completed, the average plane of the slopes shall conform to the slopes indicated on the plans and no point on the completed slopes shall vary from the designated slopes by more than 300 mm. These tolerances shall be measured perpendicular to the plane of the slope. In no case shall any portion of the slope encroach on the side drains.

As long as equally satisfactory presplit slopes are obtained, then either the slope face may be presplit before drilling for production blasting or presplitting the slope face and production blasting may be done at the same time, provided that the presplitting drill holes are fired with zero delay and the production holes are delayed starting at the row of holes farthest from the slope and progressing in steps to the row of holes nearest the presplit lines, which row shall be delayed at least 50 milliseconds. In either case the presplitting holes shall extend either to the end of the excavation or for a distance of not less than 15 m beyond the limits of the production holes to be detonated.

Measurements for Payment

The area of presplitting to be paid for, will be measured as square metres of acceptable presplit slope surface.

Rates

The Contract unit rate for presplitting work shall be payment in full for carrying out the required operations for obtaining acceptable presplit slope surfaces. The quantity of rock excavated through the production/presplit holes shall be paid for as per Clause 301.9.1.

304 EXCAVATION FOR STRUCTURES

Scope

Excavation for structures shall consist of the removal of material for the construction of foundations for bridges, culverts, retaining walls, headwalls, cutoff walls, pipe culverts and other similar structures, in accordance with the requirements of these Specifications and the lines and dimensions shown on the drawings or as indicated by the Engineer. The work shall include construction of the necessary cofferdams and cribs and their subsequent removal; all necessary sheeting, shoring, bracing, draining and pumping; the removal of all logs, stumps, grubs and other deleterious matter and obstruction, necessary for placing the foundations; trimming bottoms of excavations; backfilling and clearing up the site and the disposal of all surplus material.

Classification of Excavation

All materials involved in excavation shall be classified in accordance with Clause 301.2.

Construction Operations

Setting Out

After the site has been cleared according to Clause 201, the limits of excavation shall be set out true to lines, curves and slopes to Clause 301.3.1.

Excavation

Excavation shall be taken to the width of the lowest step of the footing including additional width as required for construction operation. The sides shall be left plumb where the nature of soil allows it. Where the nature of soil or the depth of the trench and season of the year do not permit vertical sides, the Contractor at his own cost shall put up necessary shoring, strutting and planking or cut slopes to a safer angle or both with due regard to the safety of personnel and works and to the satisfaction of the Engineer.

The depth to which the excavation is to be carried out shall be as shown on the drawings, unless the type of material encountered is such as to require changes, in which case the depth shall be as ordered by the Engineer. Propping shall be undertaken when any foundation or stressed zone from an adjoining structure is within a line of 1 vertical to 2 horizontal from the bottom of the excavation.

Where blasting is to be resorted to, the same shall be carried out in accordance with Clause 302 and all precautions indicated therein observed. Where blasting is likely to

endanger adjoining foundations or other structures, necessary precautions such as controlled blasting, providing rubber mat cover to prevent flying of debris etc. shall be taken to prevent any damage.

Dewatering and Protection

Normally, open foundations shall be laid dry. Where water is met with in excavation due to stream flow, seepage, springs, rain or other reasons, the Contractor shall take adequate measures such as bailing, pumping, constructing diversion channels, drainage channels, bunds, depression of water level by well-point system, cofferdams and other necessary works to keep the foundation trenches dry when so required and to protect the green concrete/ masonry against damage by erosion or sudden rising of water level. The methods to be adopted in this regard and other details thereof shall be left to the choice of the Contractor but subject to the approval of the Engineer. Approval of the Engineer shall, however, not relieve the Contractor of the responsibility for the adequacy of dewatering and protection arrangements for the quality and safety of the works.

Where cofferdams are required, these shall be carried to adequate depths and heights, be safely designed and constructed and be made as watertight as is necessary for facilitating construction to be carried out inside them. The interior dimensions of the cofferdams shall be such as to give sufficient clearance for the construction and inspection and to permit installation of pumping equipments, etc., inside the enclosed area.

If it is determined beforehand that the foundations cannot be laid dry or the situation is found that the percolation is too heavy for keeping the foundation dry, the foundation concrete shall be laid under water by tremie pipe only. In case of flowing water or artesian springs, the flow shall be stopped or reduced as far as possible at the time of placing the concrete.

Pumping from the interior of any foundation enclosure shall be done in such a manner as to preclude the possibility of the movement of water through any fresh concrete. No pumping shall be permitted during the placing of concrete and for a period of at least 24 hours thereafter, unless it is done from a suitable sump separated from the concrete work by a watertight wall or other similar means.

At the discretion of the Contractor, cement grouting or other approved methods may be used to prevent or reduce seepage and to protect the excavation area.

The Contractor shall take all precautions in diverting channels and in discharging the drained water as not to cause damage to the works, crops or any other property.

Preparation of Foundation

The bottom of the foundation shall be levelled both longitudinally and transversely or stepped as directed by the Engineer. Before footing is laid, the surface shall be slightly watered and

rammed. In the event of excavation having been made deeper than that shown on the drawings or as otherwise ordered by the Engineer, the extra depth shall be made up with concrete as per Clause 2104.1 at the cost of the Contractor. Ordinary filling shall not be permitted to bring the foundation to the design level as shown in the drawing.

When rock or other hard strata is encountered, it shall be freed of all soft and loose material, cleaned and cut to a firm surface either level or stepped as directed by the Engineer. All seams shall be cleaned out and filled with cement mortar or grout to the satisfaction of the Engineer. In the case of excavation in rock, annular space around footing shall be filled with lean concrete M 15 upto the top level of rock.

If the depth of fill required is more than 1.5 m in soft rock or 0.6 m in hard rock above the foundation level, the filling upto this level shall be done with M-15 concrete and portion above shall be filled by concrete or by boulders grouted with cement.

When foundation piles are used, the excavation for pile cap shall be done after driving/casting of all piles forming the group. After pile driving operations in a given pit are completed, all loose and displaced materials therein shall be removed to the level of the bottom of the pilecap.

Slips and Slip-Outs

If there are any slips or slip-outs in the excavation, these shall be removed by the Contractor at his own cost.

Public Safety

Near towns, villages and all frequented places, trenches and foundation pits shall be securely fenced, provided with proper caution signs and marked with red lights at night to avoid accidents. The Contractor shall take adequate protective measures to see that the excavation operations do not affect or damage adjoining structures. For safety precautions, guidance may be taken from IS:3764.

Backfilling

Backfilling shall be done with approved material after concrete or masonry is fully set and carried out in such a way as not to cause undue thrust on any part of the structure. All space between foundation masonry or concrete and the sides of excavation shall be refilled to the original surface in layers not exceeding 150 mm compacted thickness. The compaction shall be done with the help of suitable equipment such as trench compactor, mechanical tamper, rammer, plate vibrator etc., after necessary watering, so as to achieve the maximum dry density.

Disposal of Surplus Excavated Materials

Clause 301.3.11 shall apply.

Measurements for Payment

Excavation for structures shall be measured in cu.m for each class of material encountered, limited to the dimensions shown on the drawings or as directed by the Engineer. Excavation over increased width, cutting of slopes, production/support to the existing structures shoring, shuttering and planking shall be deemed as incidental to the main work and shall not be measured and paid separately.

Preparation of rock foundation shall be measured in square metres.

Rates

The Contract unit rate for the items of excavation for structures shall be payment in full for carrying out the required operations including full compensation for:

- i) setting out;
- ii) transporting the excavated materials for use or disposal with all leads and lifts;
- iii) construction of necessary cofferdams, cribs/sheeting, shoring and bracing and their subsequent removal;
- iv) removal of all logs, stumps, grubs and other deleterious matter and obstructions, for placing the foundations including trimming of bottoms of excavations;
- v) foundation sealing, dewatering including pumping when no separate provision for it is made in the Contract;
- vi) backfilling, clearing up the site and disposal of all surplus material with all leads and lifts or as otherwise specified; and
- vii) all labour, materials, tools, equipment, safety measures, diversion of traffic and incidentals necessary to complete the work to Specifications.

The Contract unit rate for preparation of rock foundation shall be full compensation for cutting, trimming and cleaning the foundation surface and filling/sealing of all seams with cement grout or mortar including all materials, labour and incidentals required for completing the work.

305 EMABANKMENT CONSTRUCTION

General

305.1.1 Description

These Specifications shall apply to the construction of embankments including sub-grades, earthen shoulders and miscellaneous backfills with approved material obtained from approved source, including material from roadway and drain excavation, borrow pits or other sources. All embankments sub-grades, earthen shoulders and miscellaneous backfills shall be constructed in accordance with the requirements of these Specifications and in conformity with the lines, grades, and cross-sections shown on the drawings or as directed by the Engineer.

Materials and General Requirements

Physical Requirements

The materials used in embankments, subgrades, earthen shoulders and miscellaneous backfills shall be soil, moorum, gravel, reclaimed material from pavement, fly ash, pond ash, a mixture of these or any other material as approved by the Engineer. Such materials shall be free of logs, stumps, roots, rubbish or any other ingredient likely to deteriorate or affect the stability of the embankment.

The following types of material shall be considered unsuitable for embankment:

- a) Materials from swamps, marshes and bogs;
- b) Peat, log, stump and perishable material; any soil that classifies as OL, OI, OH or Pt in accordance with IS:1498;
- c) Materials susceptible to spontaneous combustion;
- d) Materials in a frozen condition;
- e) Clay having liquid limit exceeding 50 and plasticity index exceeding 25;
and

- f) Materials with salts resulting in leaching in the embankment.

Expansive clay exhibiting marked swell and shrinkage properties ("free swelling index" exceeding 50 percent when tested as per IS:2720 – Part 40) shall not be used as a fill material. Where an expansive clay having "free swelling index" value less than 50 percent is used as a fill material, subgrade and top 500 mm portion of the embankment just below sub-grade shall be non-expansive in nature.

Section 300 Earthwork, Erosion Control and Drainage

Any fill material with a soluble sulphate content exceeding 1.9 grams of sulphate (expressed as SO_3) per litre when tested in accordance with BS:1377, Part 3, but using a 2:1 water-soil ratio shall not be deposited within 500 mm distance (or any other distance described in the Contract), of permanent works constructed out of concrete, cement bound materials or other cementitious material.

Materials with a total sulphate content (expressed as SO_3) exceeding 0.5 percent by mass, when tested in accordance with BS:1377, Part 3 shall not be deposited within 500 mm, or other distances described in the Contract, of metallic items forming part of the Permanent Works.

The size of the coarse material in the mixture of earth shall ordinarily not exceed 75 mm when placed in the embankment and 50 mm when placed in the sub-grade. However, the Engineer may at his discretion permit the use of material coarser than this also if he is satisfied that the same will not present any difficulty as regards the placement of fill material and its compaction to the requirements of these Specifications. The maximum particle size in such cases, however, shall not be more than two-thirds of the compacted layer thickness.

Ordinarily, only the materials satisfying the density requirements given in Table 300-1 shall be employed for the construction of the embankment and the sub-grade.

Table 300-1 : Density Requirements of Embankment and Sub-grade Materials

S. No.	Type of Work	Maximum laboratory dry unit weight when tested as per IS:2720 (Part 8)
1)	Embankments up to 3 m height, not subjected to extensive flooding	Not less than 15.2 kN/cu.m
2)	Embankments exceeding 3 m height or embankments of any height subject to long periods of inundation	Not less than 16 kN/ cu.m
3)	Subgrade and earthen shoulders/verges/backfill	Not less than 17.5 kN/cu.m

- Notes:**
- 1) This Table is not applicable for lightweight fill material, e.g., cinder, fly ash, etc.
 - 2) The material to be used in subgrade shall be non-expansive and shall satisfy design CBR at the specified dry density and moisture content. In case the available materials fail to meet the requirement of CBR, use of stabilization methods in accordance with Clauses 403 and 404 or by any stabilization method approved by the Engineer shall be followed.

The material to be used in subgrade shall conform to the design CBR value at the specified dry density and moisture content of the test specimen. In case the available

materials fails to meet the requirement of CBR, use of stabilization methods in accordance with Clauses 403 and 404 or by any stabilization method approved by the Engineer or by the IRC Accreditation Committee shall be followed.

The material to be used in high embankment construction shall satisfy the specified requirements of strength parameters.

General Requirements

The materials for embankment shall be obtained from approved sources with preference given to acceptable materials becoming available from nearby roadway excavation under the same Contract.

The work shall be so planned and executed that the best available materials are saved for the subgrade and the embankment portion just below the subgrade.

Borrow Materials

The arrangement for the source of supply of the material for embankment and sub-grade and compliance with the guidelines, and environmental requirements, in respect of excavation and borrow areas as stipulated, from time to time by the Ministry of Environment and Forests, Government of India and the local bodies, as applicable shall be the sole responsibility of the Contractor.

Borrow pits along the road shall be discouraged. If permitted by the Engineer, these shall not be dug continuously. Ridges of not less than 8 m width should be left at intervals not exceeding 300 m. Small drains shall be cut through the ridges to facilitate drainage. The depth of the pits shall be so regulated that their bottom does not cut an imaginary line having a slope of 1 vertical to 4 horizontal projected from the edge of the final section of the bank, the maximum depth in any case being limited to 1.5 m. Also, no pit shall be dug within the offset width of a minimum of 10 m.

Haulage of material to embankments or other areas of fill shall proceed only when sufficient spreading and compaction plant is operating at the place of deposition.

Where the excavation reveals a combination of acceptable and unacceptable materials, the Contractor shall, unless otherwise agreed by the Engineer, carry out the excavation in such a manner that the

acceptable materials are excavated separately for use in the permanent works without contamination by the unacceptable materials. The acceptable materials shall be stockpiled separately.

The Contractor shall ensure that he does not adversely affect the stability of excavation or fills by the methods of stockpiling materials, use of plants or siting of temporary buildings or structures.

Fly-Ash

Use of fly-ash shall conform to the Ministry of Environment and Forest guidelines. Where fly-ash is used the embankment construction shall conform to the physical and chemical properties and requirements of IRC:SP:38-2001, “Guidelines for Use of Flyash in Road Construction”. The term fly-ash shall cover all types of coal ash such as pond ash, bottom ash or mound ash.

Embankment constructed out of fly ash shall be properly designed to ensure stability and protection against erosion in accordance with IRC guidelines. A suitable thick cover may preferably be provided at intervening layers of pond ash for this purpose. A thick soil cover shall bind the edge of the embankment to protect it against erosion. Minimum thickness of such soil cover shall be 500 mm.

Compaction Requirements

The Contractor shall obtain representative samples from each of the identified borrow areas and have these tested at the site laboratory following a testing programme approved by the Engineer. It shall be ensured that the subgrade material when compacted to the density requirements as in Table 300-2 shall yield the specified design CBR value of the sub-grade.

Table 300-2 : Compaction Requirements for Embankment and Sub-grade

S. No.	Type of work/material	Relative compaction as percentage of max. laboratory dry density as per IS:2720 (Part 8)
1)	Subgrade and earthen shoulders	Not less than 97%
2)	Embankment,	Not less than 95%
3)	Expansive Clays	
	a) Subgrade and 500 mm portion just below the subgrade	Not allowed
	b) Remaining portion of embankment	90–95%

The Contractor shall at least 7 working days before commencement of compaction submit

the following to the Engineer for approval:

- i) The values of maximum dry density and optimum moisture content obtained in accordance with IS:2720 (Part 8), appropriate for each of the fill materials he intends to use.
- ii) A graph of dry density plotted against moisture content from which each of the values in (i) above of maximum dry density and optimum moisture content were determined.

The maximum dry density and optimum moisture content approved by the Engineer shall form the basis for compaction.

Construction Operations

Setting Out

After the site has been cleared to Clause 201, the work shall be set out to Clause 301.3.1 The limits of embankment/sub-grade shall be marked by fixing batter pegs on both sides at regular intervals as guides before commencing the earthwork. The embankment/sub-grade shall be built sufficiently wider than the design dimension so that surplus material may be trimmed, ensuring that the remaining material is to the desired density and in position specified and conforms to the specified side slopes.

Dewatering

If the foundation of the embankment is in an area with stagnant water, and in the opinion of the Engineer it is feasible to remove it, the same shall be removed by bailing out or pumping, as directed by the Engineer and the area of the embankment foundation shall be kept dry. Care shall be taken to discharge the drained water so as not to cause damage to the works, crops or any other property. Due to any negligence on the part of the Contractor, if any such damage is caused, it shall be the sole responsibility of the Contractor to repair/restore it to original condition or compensate for the damage at his own cost.

If the embankment is to be constructed under water, Clause 305.4.6 shall apply.

Stripping and Storing Topsoil

When so directed by the Engineer, the topsoil from all areas of cutting and from all areas to be covered by embankment foundation shall be stripped to specified depths not exceeding 150 mm and stored in stockpiles of height not exceeding 2 m for covering embankment slopes, cut slopes and

other disturbed areas where re-vegetation is desired. Topsoil shall not be unnecessarily subjected to traffic either before stripping or when in a stockpile. Stockpiles shall not be surcharged or otherwise loaded and multiple handling shall be kept to a minimum.

Compacting Ground Supporting Embankment/Sub-Grade

Where necessary, the original ground shall be levelled to facilitate placement of first layer of embankment, scarified, mixed with water and then compacted by rolling in accordance with Clauses 305.3.5 and 305.3.6 so as to achieve minimum dry density as given in Table 300-2.

In case where the difference between the sub-grade level (top of the sub-grade on which pavement rests) and ground level is less than 0.5 m and the ground does not have 97 percent relative compaction with respect to the dry density (as given in Table 300-2), the ground shall be loosened upto a level 0.5 m below the sub-grade level, watered and compacted in layers in accordance with Clauses 305.3.5 and 305.3.6 to achieve dry density not less than 97 percent relative compaction as given in Table 300-2.

Where so directed by the Engineer, any unsuitable material occurring in the embankment foundation (500 mm portion just below the sub-grade) shall be removed, suitably disposed and replaced by approved materials laid in layers to the required degree of compaction.

Any foundation treatment specified for embankments especially high embankments, resting on suspect foundations as revealed by borehole logs shall be carried out in a manner and to the depth as desired by the Engineer. Where the ground on which an embankment is to be built has any of such material types (a) to (f) in Clause 305.2.1.1 at least 500 mm of such material must be removed and replaced by acceptable fill material before embankment construction commences.

Spreading Material in Layers and Bringing to Appropriate Moisture Content

The embankment and sub-grade material shall be spread in layers of uniform thickness in the entire width with a motor grader. The compacted thickness of each layer shall not be more than 250 mm when vibratory roller/vibratory soil compactor is used and not more than 200 mm when 80-100 kN static roller is used. The motor grader blade shall have hydraulic control suitable for initial adjustment and maintain the same so as to achieve the specific slope and grade. Successive layers shall not be placed until the layer under construction has been thoroughly compacted to the specified requirements as in Table 300-2 and got approved by the Engineer. Each compacted layer shall be finished parallel to the final cross-section of the embankment.

Moisture content of the material shall be checked at the site of placement prior to commencement of compaction; if found to be out of agreed limits, the same shall be made good.

Where water is required to be added in such constructions, water shall be sprinkled from a water tanker fitted with sprinkler capable of applying water uniformly with a controllable rate of flow to variable widths of surface but without any flooding. The water shall be added uniformly and thoroughly mixed in soil by blading, using disc harrow until a uniform moisture content is obtained throughout the depth of the layer.

If the material delivered to the roadbed is too wet, it shall be dried, by aeration and exposure to the sun, till the moisture content is acceptable for compaction. Should circumstances arise, where owing to wet weather, the moisture content cannot be reduced to the required amount by the above procedure, compaction work shall be suspended.

Moisture content of each layer of soil shall be checked in accordance with IS:2720 (Part 2), and unless otherwise mentioned, shall be so adjusted, making due allowance for evaporation losses, that at the time of compaction it is in the range of 1 percent above to 2 percent below the optimum moisture content determined in accordance with IS:2720 (Part 8) as the case may be. Expansive clays shall, however, be compacted at moisture content corresponding to the specified dry density, but on the wet side of the optimum moisture content obtained from the laboratory compaction curve.

After adding the required amount of water, the soil shall be processed by means of graders, harrows, rotary mixers or as otherwise approved by the Engineer until the layer is uniformly wet.

Clods or hard lumps of earth shall be broken to have a maximum size of 75 mm when being placed in the embankment and a maximum size of 50 mm when being placed in the sub-grade.

Embankment and other areas of fill shall, unless otherwise required in the Contract or permitted by the Engineer, be constructed evenly over their full width and their fullest possible extent and the Contractor shall control and direct construction plant and other construction vehicles. Damage by construction plant and other vehicular traffic shall be made good by the Contractor with material having the same characteristics and strength of the material before it was damaged.

Embankments and unsupported fills shall not be constructed with steeper side slopes or to greater widths than those shown in the drawings, except to permit adequate compaction at the edges before trimming back, or to obtain the final profile following any settlement of the fill and the underlying material,

Whenever fill is to be deposited against the face of a natural slope, or sloping earthworks face including embankments, cuttings, other fills and excavations steeper than 1 vertical to 4 horizontal, such faces shall be benched as per Clause 305.4.1 immediately before placing the subsequent fill.

All permanent faces of side slopes of embankments and other areas of fill shall, subsequent to any trimming operations, be reworked and sealed to the satisfaction of the Engineer by tracking a tracked vehicle, considered suitable by the Engineer, on the slope or any other method approved by the Engineer.

Compaction

Only the compaction equipment approved by the Engineer shall be employed to compact the different material types encountered during construction. Static three-wheeled roller, self-propelled single drum vibratory roller, tandem vibratory roller, pneumatic tyre roller, pad foot

roller, etc., of suitable size and capacity as approved by the Engineer shall be used for the different types and grades of materials required to be compacted either individually or in suitable combinations.

The compaction shall be done with the help of self-propelled single drum vibratory roller or pad foot vibratory roller of 80 to 100 kN static weight or heavy pneumatic tyre roller of adequate capacity capable of achieving the required compaction. The Contractor shall demonstrate the efficacy of the equipment he intends to use by carrying out compaction trials. The procedure to be adopted for the site trials shall be submitted to the Engineer for approval.

Earthmoving plant shall not be accepted as compaction equipment nor shall the use of a lighter category of plant to provide any preliminary compaction to assist the use of heavier plant be taken into account.

Each layer of the material shall be thoroughly compacted to the densities specified in Table 300-2. Subsequent layers shall be placed only after the finished layer has been tested according to Clause 903.2.2 and accepted by the Engineer. The Engineer may permit measurement of field dry density by a nuclear moisture/density gauge used in accordance with agreed procedure and provided the gauge is calibrated to give results identical to that obtained from tests in accordance with IS:2720 (Part 28). A record of the same shall be maintained by the Contractor.

When density measurements reveal any soft areas in the embankment/sub-grade/earthen shoulders, further compaction shall be carried out as directed by the Engineer. If in spite of that the specified compaction is not achieved, the material in the soft areas shall be removed and replaced by approved material, compacted using appropriate mechanical means such as light weight vibratory roller, double drum walk behind roller, vibratory plate compactor, trench compactor or vibratory tamper to the density requirements and satisfaction of the Engineer.

Drainage

The surface of the embankment/sub-grade at all times during construction shall be maintained at such a crossfall (not flatter than that required for effective drainage of an earthen surface) as will shed water and prevent ponding.

Repairing of Damages Caused by Rain/Spillage of Water

The soil in the affected portion shall be removed in such areas as directed by the Engineer before next layer is laid and refilled in layers and compacted using appropriate mechanical means such as small vibratory roller, plate compactor or power rammer to achieve the required density in accordance with Clause 305.3.6. If the cut is not sufficiently wide for use of required mechanical means for compaction, the same shall be widened suitably to permit their use for proper compaction. Tests shall be carried out as directed by the Engineer to ascertain the density requirements of the repaired area. The work of repairing the damages including widening of the cut, if any, shall be carried out by the Contractor at his own cost, including the arranging of machinery/equipment for the purpose.

Finishing Operations

Finishing operations shall include the work of shaping and dressing the shoulders/verge/ roadbed and side slopes to conform to the alignment, levels, cross-sections and dimensions shown on the drawings or as directed by the Engineer subject to the surface tolerance described in Clause 902. Both the upper and lower ends of the side slopes shall be rounded off to improve appearance and to merge the embankment with the adjacent terrain.

The topsoil, removed and conserved earlier (Clauses 301.3.2 and 305.3.3) shall be spread over the fill slopes as per directions of the Engineer to facilitate the growth of vegetation. Slopes shall be roughened and moistened slightly prior to the application of the topsoil in order to provide satisfactory bond. The depth of the topsoil shall be sufficient to sustain plant growth, the usual thickness being from 75 mm to 150 mm.

Where directed, the slopes shall be turfed with sods in accordance with Clause 307. If seeding and mulching of slopes is prescribed, this shall be done to the requirements of Clause 308.

When earthwork operations have been substantially completed, the road area shall be cleared of all debris, and ugly scars in the construction area responsible for objectionable appearance eliminated.

Construction of Embankment and Sub-grade under Special Conditions

Earthwork for Widening Existing Road Embankment

When an existing embankment and/or sub-grade is to be widened and its slopes are steeper than 1 vertical on 4 horizontal, continuous horizontal benches, each at least 300 mm wide, shall be cut into the old slope for ensuring adequate bond with the fresh embankment/sub-grade material to be added. The material obtained from cutting of benches could be utilized in the widening of the embankment/subgrade. However, when the existing slope against which the fresh material is to be placed is flatter than 1 vertical on 4 horizontal, the slope surface may only be ploughed or scarified instead of resorting to benching.

Where the width of the widened portions is insufficient to permit the use of conventional rollers, compaction shall be carried out with the help of light weight vibratory roller, double drum walk behind roller, vibratory plate compactor or vibratory tamper or any other appropriate equipment approved by the Engineer. End dumping of material from trucks for widening operations shall be avoided except in difficult circumstances when the extra width is too narrow to permit the movement of any other types of hauling equipment.

Earthwork for Embankment and Sub-Grade to be Placed Against Sloping Ground

Where an embankment/subgrade is to be placed against sloping ground, the latter shall be appropriately benched or ploughed/scarified as required in Clause 305.4.1 before placing the embankment/sub-grade material. Extra earthwork involved in benching or due to ploughing/scarifying etc. shall be considered incidental to the work.

For wet conditions, benches with slightly inward fall and subsoil drains at the lowest point shall be provided as per the drawings, before the fill is placed against sloping ground.

Where the Contract requires construction of transverse subsurface drain at the cut-fill interface, work on the same shall be carried out to Clause 309 in proper sequence with the embankment and sub-grade work as approved by the Engineer.

Earthwork over Existing Road Surface

Where the embankment is to be placed over an existing road surface, the work shall be carried out as indicated below:

- i) If the existing road surface is of granular type and lies within 1 m of the new formation levels, it shall be scarified to a depth of 50 mm or as directed so as to provide ample bond

- between the old and new material ensuring that at least 500 mm portion below the top of new sub-grade level is compacted to the desired density;
- ii) If the existing road surface is of bituminous type or cement concrete and lies within 1 m of the new formation level, the bituminous or cement concrete layer shall be removed completely;
 - iii) If the level difference between the existing road surface and the new formation level is more than 1 m, the existing surface shall be roughened after ensuring that the minimum thickness of 500 mm of subgrade is available.

Embankment and Sub-Grade Around Structures

To avoid interference with the construction of abutments, wing walls or return walls of culvert/bridge structures, the Contractor shall, at points, to be determined by the Engineer suspend work on embankment forming approaches to such structures, until such time as the construction of the latter is sufficiently advanced to permit the completion of approaches without the risk of damage to the structure.

Unless directed otherwise, the filling around culverts, bridges and other structures upto a distance of twice the height of the road from the back of the abutment shall be carried out independent of the work on the main embankment. The fill material shall not be placed against any abutment or wing wall, unless permission has been given by the Engineer but in any case not until the concrete or masonry has been in position for 14 days. The embankment and sub-grade shall be brought up simultaneously in equal layers on each side of the structure to avoid displacement and unequal pressure. The sequence of work in this regard shall be got approved from the Engineer.

The material used for backfill shall not be an organic soil or highly plastic clay having plasticity index and liquid limit more than 20 and 40 respectively when tested according to IS:2720 (Part 5). Filling behind abutments and wing walls for all structures shall conform to the general guidelines given in IRC:78. The fill material shall be deposited in horizontal layers in loose thickness and compacted thoroughly to the requirements of Table 300-2.

Where the provision of any filter medium is specified behind the abutment, the same shall be laid in layers simultaneously with the laying of fill material. The material used for filter shall conform to the requirements for filter medium spelt out in Clause 2504 unless otherwise specified in the Contract.

Where it may be impracticable to use conventional rollers, the compaction shall be carried out by appropriate mechanical means such as small vibratory roller, plate compactor or power rammer. Care shall be taken to see that the compaction equipment does not hit or come too close to any structural member so as to cause any damage to them or excessive pressure against the structure.

Construction of Embankment over Ground Incapable of Supporting Construction Equipment

Where embankment is to be constructed across ground which will not support the weight of repeated heavy loads of construction equipment, the first layer of the fill may be constructed by placing successive loads of material in a uniformly distributed layer of a minimum thickness required to support the construction equipment as permitted by the Engineer. The Contractor, if so desired by him, may also use suitable geosynthetic material to increase the bearing capacity of the foundation. This exception to normal procedure will not be permitted where, in the opinion of the Engineer, the embankments could be constructed in the approved manner over such ground by the use of lighter or modified equipment after proper ditching and drainage have been provided. Where this exception is permitted, the selection of the material and the construction procedure to obtain an acceptable layer shall be the responsibility of the Contractor. The cost of providing suitable traffic conditions for construction equipment over any area of the Contract will be the responsibility of the Contractor and no extra payment will be made to him. The remainder of the embankment shall be constructed as specified in Clause 305.3.

Embankment Construction under Water and Waterlogged Areas

Embankment Construction under Water

Where filling or backfilling is to be placed under water, only acceptable granular material or rock shall be used unless otherwise approved by the Engineer. Acceptable granular material shall be of GW, SW, GP, SP as per IS:1498 and consist of graded, hard durable particles with maximum particle size not exceeding 75 mm. The material should be non-plastic having uniformity coefficient of not less than 10. The material placed in open water shall be deposited by end tipping without compaction.

Embankment Construction in Waterlogged and Marshy Areas

The work shall be done as per IRC:34.

Earthwork for High Embankment

The material for high embankment construction shall conform to Clause 305.2.1.7. In the case of high embankments (more than 6 m), the Contractor shall normally use fly ash in conformity with Clause 305.2.1.1 or the material from the approved borrow area.

Where provided, stage construction of embankment and controlled rates of filling shall be carried out in accordance with the Contract including installation of instruments and its monitoring.

Where required, the Contractor shall surcharge embankments or other areas of fill with approved material for the periods specified in the Contract. If settlement of surcharged fill results the Contractor shall bring the resultant level up to formation level with acceptable material for use in fill.

Settlement Period

Where settlement period is specified in the Contract, the embankment shall remain in place for the required settlement period before excavating for abutment, wing wall, retaining wall, footings, etc., or driving foundation piles. The duration of the required settlement period at each location shall be as provided for in the Contract or as directed by the Engineer.

Plying of Traffic

Construction and other vehicular traffic shall not use the prepared surface of the embankment and/or sub-grade without the prior permission of the Engineer. Any damage arising out of such use shall, however, be made good by the Contractor at his own cost as directed by the Engineer.

Surface Finish and Quality Control of Work

The surface finish of construction of sub-grade shall conform to the requirements of Clause 902. Control on the quality of materials and works shall be exercised in accordance with Clause 903.

Sub-grade Strength

It shall be ensured prior to actual execution that the material to be used in the sub-grade satisfies the requirements of design CBR.

Sub-grade shall be compacted and finished to the design strength consistent with other physical requirements. The actual laboratory CBR values of constructed sub-grade shall be determined on remoulded samples, compacted to the field density at the field moisture content and tested for soaked/unsoaked condition as specified in the Contract.

Measurements for Payment

Earth embankment/sub-grade construction shall be measured separately by taking cross sections at intervals given in Sub-Section 113.3 after completion of clearing and grubbing and after completion

of embankment/sub-grade. The volume of earthwork shall be computed in cubic metres by the method of average end areas.

The measurement of fill material from borrow areas shall be the difference between the net quantities of compacted fill and the net quantities of suitable material brought from roadway and drainage excavation. For this purpose, it shall be assumed that one cu.m of suitable material brought to site from road and drainage excavation forms one cu.m of compacted fill and all bulking or shrinkage shall be ignored.

The embankment constructed with fly ash will be measured in cu.m, separately for the fly ash portions and for the soil cover and intervening layers of soil, unless otherwise specified in the Contract.

Construction of embankment under water shall be measured in cu.m.

Construction of high embankment with specified material and in specified manner shall be measured in cu.m.

Stripping including storing and reapplication of top soil shall be measured in cu.m.

Work involving loosening and recompacting of ground supporting embankment/sub-grade shall be measured in cu.m.

Section 300 Earthwork, Erosion Control and Drainage

Removal of unsuitable material at embankment/sub-grade foundation and replacement with suitable material shall be measured in cu.m.

Scarifying existing granular/bituminous road surface shall be measured in square metres.

Dismantling and removal of existing cement concrete pavement shall be measured vide Clause 202.6.

Filter medium and backfill material behind abutments, wing walls and other retaining structures shall be measured as finished work in position in cu.m.

Rates

The Contract unit rates for the items of embankment and sub-grade construction shall be payment in full for carrying out the required operations including full compensation for:

- i) Cost of arrangement of land as a source of supply of material of required quantity for construction unless provided otherwise in the Contract;
 - ii) Setting out;
 - iii) Compacting ground supporting embankment/sub-grade except where removal and replacement of suitable material or loosening and recompacting is involved;
 - iv) Scarifying or cutting continuous horizontal benches 300 mm wide on side slopes of existing embankment and sub-grade as applicable;
 - v) Cost of watering or drying of material in borrow areas and/or embankment and sub-grade during construction as required;
 - vi) Spreading in layers, bringing to appropriate moisture and compacting to Specification requirements;
 - vii) Shaping and dressing top and slopes of the embankment and sub-grade including rounding of corners;
 - viii) Restricted working at sites of structures;
 - ix) Working on narrow width of embankment and sub-grade;
 - x) Excavation in all soils from borrow pits/designated borrow areas including clearing and grubbing and transporting the material to embankment and sub-grade site with all leads and lifts unless otherwise provided for in the Contract;
 - xi) All labour, materials, tools, equipment and incidentals necessary to complete the work to the Specifications;
 - xii) Dewatering; and
- Earthwork, Erosion Control and Drainage Section 300
- xiii) Keeping the embankment/completed formation free of water as per Clause 311
 - xiv) Transporting unsuitable excavated material for disposal with all leads and lifts.

Clause 301.9.5 shall apply as regards Contract unit rates for items of stripping and storing top soil including reapplication of topsoil.

Clause 301.9.2 shall apply as regards Contract unit rate for the item of loosening and recompacting the embankment/sub-grade foundation.

Clauses 309.1.1 and 305.8 shall apply as regards Contract rates for items of removal of unsuitable material and replacement with suitable material, respectively.

The Contract unit rate for scarifying existing granular/bituminous road surfaces shall be payment in full for carrying out the required operations including full compensation for all labour, materials, tools,

equipment and incidentals, necessary to complete the work. This will also comprise of handling, giving credit towards salvage value and disposal of the dismantled materials with all leads and lifts or as otherwise specified.

Clause 202.7 shall apply as regards Contract unit rate for dismantling and removal of existing cement concrete pavement.

The Contract unit rate for providing and laying filter material shall be payment in full for carrying out the required operations including all materials, labour, tools, equipment and incidentals to complete the work to Specifications.

The Contract unit rate for providing and compacting backfill material behind abutments and retaining walls shall be payment in full for carrying out the required operations including all materials, labour, tools, equipment and incidentals to complete the work to Specifications.

Clause 305.4.6 shall apply as regards Contract unit rate for construction of embankment under water.

Clause 305.4.7 shall apply as regards Contract unit rate for construction of high embankment. It shall include cost of instrumentation, its monitoring and settlement period, where specified in the Contract or directed by the Engineer.

306 SOIL EROSION AND SEDIMENTATION CONTROL

Description

This work shall consist of measures as shown on drawings or as directed by the Engineer to

control soil erosion, sedimentation and water pollution, through use of berms, dikes, sediment basins, fibre mats, mulches, grasses, slope drains, and other devices.

Materials

All materials shall meet commercial grade standards and shall be approved by the Engineer before being used in the work

Construction Operations

Prior to the start of the relevant construction, the Contractor shall submit to the Engineer for approval his schedules for carrying out temporary and permanent erosion/sedimentation control works as are applicable for the items of clearing and grubbing, roadway and drainage excavation, embankment/sub-grade construction, bridges and other structures across water courses, pavement courses and shoulders. He shall also submit for approval his proposed method of erosion/sedimentation control on service road and borrow pits and his plan for disposal of waste materials. Work shall not be started until the erosion/sedimentation control schedules and methods of operations for the applicable construction have been approved by the Engineer.

The surface area of erodible earth material exposed by clearing and grubbing, excavation, borrow and fill operations shall be limited to the extent practicable. The Contractor shall provide immediate permanent or temporary erosion, slope protection and sedimentation control measures to prevent soil erosion and sedimentation that will adversely affect construction operations, damage adjacent properties, or cause contamination of nearby streams or other water courses, lakes, reservoirs etc. Such work may involve the construction of temporary berms, dikes, sediment basins, slope drains and use of temporary mulches, fabrics, mats seeding, or other control devices or methods as necessary to control erosion and sedimentation. Cut and fill slopes shall be seeded and turfed as shown on the drawings.

The Contractor shall be required to incorporate all permanent erosion and sedimentation control features into the project at the earliest practicable time as outlined in his accepted schedule to minimize the need for temporary erosion and sedimentation control measures.

Temporary erosion/sedimentation and pollution control measures shall be used to control the phenomenon of erosion, sedimentation and pollution that may develop during normal construction practices, but may neither be foreseen during design stage nor associated with permanent control features on the Project.

Where erosion or sedimentation is likely to be a problem, clearing and grubbing operations should be so scheduled and performed that grading operations and permanent erosion or sedimentation control features can follow immediately thereafter if the project conditions permit; otherwise temporary erosion or sedimentation control measures may be required

between successive construction stages. Under no conditions shall a large surface area of erodible earth material be exposed at one time by clearing and grubbing or excavation without prior approval of the Engineer.

The Engineer may limit the area of excavation, borrow and embankment operations in progress, commensurate with the Contractor's capability and progress in keeping the finish grading, mulching,

seeding and other such permanent erosion, sedimentation and pollution control measures, in accordance with the accepted schedule. Should seasonal limitations make such coordination unrealistic, temporary erosion/sedimentation control measures shall be taken immediately to the extent feasible and justified.

In the event temporary erosion, sedimentation and pollution control measures become necessary due to the Contractor's negligence, carelessness or failure to install permanent controls as a part of the work as scheduled or ordered by the Engineer, these shall be carried out at the Contractor's own cost. Temporary erosion, sedimentation and pollution control work required, which is not attributed to the Contractor's negligence, carelessness or failure to install permanent controls, will be performed as ordered by the Engineer.

Temporary erosion, sedimentation and pollution control may include construction work outside the right-of-way where such work is necessary as a result of road construction such as borrow pit operations, service roads and equipment storage sites.

The temporary erosion, sedimentation and pollution control features installed by the Contractor shall be acceptably maintained by him till these are needed, unless otherwise agreed by the Engineer.

Measurement for Payment

The soil erosion, sedimentation and pollution control works shall be measured in terms of units specified in the Bill of Quantities for the respective items.

Rates

The Contract unit rate for different items of soil erosion, sedimentation and pollution control works shall be payment in full for carrying out all required operations including full compensation for all labour, materials, tools, equipment and incidentals to complete the works to the Specifications.

307 TURFING WITH SODS

Scope

This work shall consist of furnishing and laying of the live sod of perennial turf forming grass on

embankment slopes, verges (earthen shoulders) or other locations shown on the drawings or as directed by the Engineer. Unless otherwise specified, the work shall be taken up as soon as possible following construction of the embankment, provided the season is favourable for establishment of the sod.

Materials

The sod shall consist of dense, well-rooted growth of permanent and desirable grasses, indigenous to the locality where it is to be used, and shall be practically free from weeds or other undesirable matter. At the time the sod is cut, the grass on the sod shall have a length of approximately 50 mm and the sod shall have been freed of debris.

Thickness of the sod shall be as uniform as possible, with some 50-80 mm or so of soil covering the grass roots depending on the nature of the sod, so that practically all the dense root system of the grasses is retained in the sod strip. The sods shall be cut in rectangular strips of uniform width, not less than about 250 mm x 300 mm in size but not so large that it is inconvenient to handle and transport these without damage. During wet weather, the sod shall be allowed to dry sufficiently to prevent tearing during handling and during dry weather shall be watered before lifting to ensure its vitality and prevent the dropping of the soil in handling.

Construction Operations

Preparation of the Earth Bed

The area to be sodded shall have been previously constructed to the required slope and cross-section. Soil on the area shall be loosened, freed of all stones larger than 50 mm size, sticks, stumps and any undesirable foreign matter, and brought to a reasonably fine granular texture to a depth of not less than 25 mm for receiving the sod.

Where required, topsoil shall be spread over the slopes. Prior to placing the topsoil, the slopes shall be scarified to a depth which, after settlement, will provide the required nominal depth shown on the drawings. Spreading shall not be done when the ground is excessively wet.

Following soil preparation and topsoiling, where required, fertilizer and ground limestone when specified shall be spread uniformly at the rate indicated on the drawings. After spreading, the materials shall be incorporated in the soil by using disc harrow or other means to the depth shown on the drawings.

Placing the Sods

The prepared sod bed shall be moistened to the loosened depth, if not already sufficiently moist, and the sod shall be placed thereon within approximately 24 hours after the same

had been cut. Each sod strip shall be laid edge to edge and such that the joints caused by abutting ends are staggered. Every strip, after it is snugly placed against the strips already in position, shall be lightly tamped with suitable wooden or metal tampers so as to eliminate airpockets and to press it into the underlying soil.

On side slopes steeper than 2 (horizontal) to 1 (vertical), the laying of sods shall be started from bottom upwards. At points where water may flow over a sodded area, the upper edges of the sod strips shall be turned into the soil below the adjacent area and a layer of earth placed over this followed by its thorough compaction.

Staking the Sods

Where the side slope is 2 (horizontal) to 1 (vertical) or steeper and the distance along the slope is more than 2 m, the sods shall be staked with pegs or nails spaced approximately 500 to 1000 mm along the longitudinal axis of the sods strips. Stakes shall be driven approximately plumb through the sods to be almost flush with them.

Top Dressing

After the sods have been laid in position, the surface shall be cleaned of loose sod, excess soil and other foreign material. Thereafter, a thin layer of topsoil shall be scattered over the surface of top dressing and the area thoroughly moistened by sprinkling with water.

Watering and Maintenance

The sods shall be watered by the Contractor for a period of at least four weeks after laying. Watering shall be so done as to avoid erosion and prevent damage to sodded areas by wheels of water tanks.

The Contractor shall erect necessary warning signs and barriers, repair or replace sodded areas failing to show uniform growth of grass or damaged by his operations and shall otherwise maintain the sod at his cost until final acceptance.

Measurements for Payment

Turfing with sods shall be measured as finished work in square metres.

Rate

The Contract unit rate for turfing with sods shall mean paying in full for carrying out all the required operations explained above including compensation for

- i) furnishing all the materials to be incorporated in the Works with all leadsand lifts; and
- ii) all labour, tools, equipment and incidentals to complete the work in accordance with these Specifications.

The Contract unit rate for application of topsoil shall be as per Clause 301.9.5.

308 SEEDING AND MULCHING

Scope

This shall consist of preparing slopes, placing topsoil, furnishing all seeds, commercial or organic fertilizers and mulching materials, providing jute netting, coir netting, or polymer netting and placing and incorporating the same on embankment slopes or other locations designated by the Engineer or shown in the Contract documents.

Materials

Seeds

The seeds shall be of approved quality and type suitable for the soil on which these are to be applied, and shall give acceptable purity and germination to requirements set down by the Engineer.

Fertilizers shall consist of standard commercial materials and conform to the grade specified. Organic manure shall be fully putrified organic matter such as cow dung.

Mulching materials shall consist of straw, hay, wood shavings, or sawdust and shall be delivered in dry condition suitable for placing with a mulch blower. They shall be reasonably free of weed seed and such foreign materials as may detract from their effectiveness as a mulch or be injurious to the plant growth.

Topsoil

Topsoil shall not be obtained from an area known to have noxious weeds growing in it. If treated with herbicide or sterilents, it shall be got tested by appropriate agricultural authority to determine the residual in the soil. Topsoil shall not contain less than 2 percent and more than 12 percent organic matter.

Bituminous Emulsion

A suitable grade of bituminous emulsion used as a tie down for mulch shall be as described in the Contract document or as desired by the Engineer. Emulsified bitumen shall not contain any solvent or diluting agent toxic to plant life.

Netting

Jute netting shall be undyed jute yarn woven into a uniform open weave with approximate 25 mm square openings.

Geonetting shall be made of uniformly extruded rectangular mesh having mesh opening of 20 mm x 20 mm. The colour may be black or green. It shall weigh not less than 3.8 kg per 1000 sqm.

A layer of biodegradable mulching material sandwiched between two layers of polymer netting or non-woven coconut fibre coir netting can also be used.

Seeding Operations

Seed-Bed Preparation

The area to be seeded shall be brought to the required slope and cross-section by filling, reshaping eroded areas and refinishing slopes, medians etc. Topsoil shall be evenly spread over the specified areas to the depth shown on the drawings, unless otherwise approved by the Engineer. The seed-bed preparation shall consist of eliminating all live plants by suitable means using agricultural implements. All stones 150 mm and larger shall be removed. The soil shall be excavated on the contour to a depth of 100 mm. All clods larger than 25 mm in diameter shall be crushed and packed. Where necessary, water shall then be applied. All topsoil shall be compacted unless otherwise specified or approved by the Engineer. Compaction shall be by slope compactor, cleated tractor or similar equipment approved by the Engineer. Equipment shall be so designed and constructed as to produce a uniform rough textured surface ready for seeding and mulching and which will bond the topsoil to the underlying material. The entire area shall be covered by a minimum of 4 passes of the roller or approved equipment.

Fertilizer Application

Fertilizer to the required quantities shall be spread and thoroughly incorporated into the soil surface as a part of the seed-bed preparation.

Planting of Seeds

All seeds shall be planted uniformly at the approved rate. Immediately after sowing, the area shall be raked, dragged or otherwise treated so as to cover the seeds to a depth of 6 mm.

The operation of seed sowing shall not be performed when the ground is muddy or when the soil or weather conditions would otherwise prevent proper soil preparation and subsequent operations.

Soil Moisture and Watering Requirements

Soil moisture shall exist throughout the zone from 25 mm to at least 125 mm below the surface at the time of planting.

Watering of the seeded areas shall be carried out as determined by the Engineer.

Mulching, Applying Bituminous Emulsion and Jute Netting/Geonetting/Netting of Coir

Within 24 hours of seeding, mulching material mixed with organic manure shall be placed so as to form a continuous, unbroken cover of approximate uniform thickness of 25 mm using an acceptable mechanical blower. Mulching material shall be held in place and made resistant to being blown away by suitable means approved by the Engineer. When called for in the Contract documents, mulch material shall be anchored in place with bituminous emulsion applied at the rate of 2300 litres per hectare. Any mulch disturbed or displaced following application shall be removed, reseeded and remulched as specified. Jute netting/geonetting or netting of coir shall be unrolled and placed parallel to the flow of water immediately following the bringing to finished grade, the area specified on the drawings or the placing of seed and fertilizer. Where more than one strip is required to cover the given areas, they shall overlap a minimum of 100 mm. Jute netting/Geonetting /coir netting shall be held in place by approved wire staples, pins, spikes or wooden stakes driven vertically into the soil.

Maintenance

The Contractor shall maintain all seeded and mulched areas until final acceptance. Maintenance shall include protection of traffic by approved warning signs or barricades and repairing any areas damaged following the seeding and mulching operations. If mulched areas become damaged, the area shall be reshaped and then seeded and mulched again as originally specified.

Measurements of Payment

Seeding and mulching shall be measured as finished work in square metres.

Rate

The Contract unit rate for seeding and mulching shall be payment in full for carrying out all the required operations including full compensation for all materials, labour, tools and incidentals.

309 SURFACE/SUB-SURFACE DRAINS

Scope

The work shall consist of constructing surface and/or sub-surface drains in accordance with the requirements of these Specifications and to the lines, grades, dimensions and other particulars shown on the drawings or as directed by the Engineer. Schedule of work shall be so arranged that the drains are completed in proper sequence with road works to ensure that no excavation of the completed road works is necessary subsequently or any damage is caused to these works due to lack of drainage.

Surface Drains

Surface drains shall be excavated to the specified lines, grades, levels and dimensions to the requirements of Clause 301. The excavated material shall be removed from the area adjoining the drains and if found suitable, utilized in embankment/sub-grade construction. All unsuitable material shall be disposed of as directed.

The excavated bed and sides of the drains shall be dressed to bring these in close conformity with the specified dimensions, levels and slopes.

Where so indicated, drains shall be lined or turfed with suitable materials in accordance with details shown on the drawings.

All works on drain construction shall be planned and executed in proper sequence with other works as approved by the Engineer, with a view to ensuring adequate drainage for the area and minimizing erosion/sedimentation.

Sub-Surface Drains

Scope

Sub-surface drains shall be of close-jointed perforated pipes, open-jointed unperforated pipes, surrounded by granular material laid in a trench or aggregate drains to drain the pavement courses. Sub-surface drains designed using Geosynthetics and approved by the Engineer can also be used.

Materials

Pipe

Perforated pipes for the drains may be metal/asbestos cement/cement concrete/Poly Vinyl

Chloride (PVC)/Poly Propylene (PP)/Poly Ethylene (PE) and unperforated pipes of metal vitrified clay/cement concrete/asbestos cement PVC/PP/PE. The type, size and grade of the pipe to be used shall be as specified in the Contract. In no case, however, shall the internal diameter of the pipe be less than 100 mm. Holes for perforated pipes shall be on one half of the circumference only and conform to the spacing indicated on the drawings. Size of the holes shall not ordinarily be greater than half of D_{85} size of the material surrounding the pipe, subject to being minimum 3 mm and maximum 6 mm. D_{85} stands for the size of the sieve that allows 85 percent of the material to pass through it.

Backfill Material

Backfill material shall consist of sound, tough, hard, durable particles of free draining sand- gravel material or crushed stone and shall be free of organic material, clay balls or other deleterious matter. Unless the Contract specifies any particular gradings for the backfill material or requires these to be designed on inverted filter criteria for filtration and permeability to the approval of the Engineer, the backfill material shall be provided on the following lines:

- i) Where the soil met with in the trench is of fine grained type (e.g., silt, clay or a mixture thereof), the backfill material shall conform to Class I grading set out in-Table 300-3;
- ii) Where the soil met with in the trench is of coarse silt to medium sand or sandy type, the backfill material shall correspond to Class II grading of Table 300-3; and
- iii) Where soil met with in the trench is gravelly sand, the backfill material shall correspond to Class III grading of Table 300-3.

Geosynthetics for use with subsurface drain shall conform to the requirements as per Section 700.

Trench Excavation

Trench for sub-surface drain shall be excavated to the specified lines, grades and dimensions shown in the drawings provided that width of trench at pipe level shall not be less than 450 mm. The excavation shall begin at the outlet end of the drain and proceed towards the upper end. Where unsuitable material is met with at the trench bed, the same shall be removed to such depth as directed by the Engineer and backfilled with approved material which shall be thoroughly compacted to the specified degree.

Laying of Pipe and Backfilling

Laying of pipe in the trench shall be started at the outlet end and proceed towards the upper end, true to the lines and grades specified.

Table 300-3 : Grading Requirements for Filter Material Percent Passing by Weight

Sieve Designation	Class I	Class II	Class III
53 mm	-	-	100
45 mm	-	-	97-100
26.5 mm	-	100	-
22.4 mm	-	95-100	58-100
11.2 mm	100	48-100	20-60
5.6 mm	92-100	28-54	4-32
2.8 mm	83-100	20-35	0-10
1.4 mm	59-96	-	0-5
710 micron	35-80	6-18	-
355 micron	14-40	2-9	-

180 micron	3-15	-	-
90 micron	0-5	0-4	0-3

Before placing the pipe, backfill material of the required grading(s) shall be laid for full width of the trench bed and compacted to a minimum thickness of 150 mm or as shown on the drawings. The thickness of the backfill material on the sides of the pipe shall be as shown on the drawings subject to a minimum of 150 mm. The pipe shall then be embedded firmly on the bed.

Perforated pipes, unless otherwise specified, shall be placed with their perforations down to minimize clogging. The pipe sections shall be joined securely with appropriate coupling fittings or bands.

Non-perforated pipes shall be laid with joints as close as possible with the open joints wrapped with suitable pervious material (like suitable Geosynthetics of not less than 150 mm width) to permit entry of water but prevent fines entering the pipes. In the case of non-perforated pipes with bell end, the bell shall face upgrade.

Upgrade end sections of the pipe installation shall be tightly closed by means of concrete plugs or plugs fabricated from the same material as the pipe and securely held in place to prevent entry of soil materials.

After the pipe installation has been completed and approved, backfill material of the required grading (s) (see Clause 309.3.2.2) shall be placed over the pipe to the required level in horizontal layers not exceeding 150 mm in thickness and thoroughly compacted. The minimum thickness of material above the top of the pipe shall be 300 mm.

Unless otherwise provided, sub-surface drains not located below the road pavement shall be sealed at the top by means of 150 mm thick layer of compacted clay so as to prevent percolation of surface water.

Use of Geosynthetics in Laying of Pipe and Backfilling

After excavating the trench for subsurface drain, the filter fabric shall be placed, the pipe installed and the trench backfilled with permeable material according to dimensions and details shown on the drawings. Surfaces to receive filter fabric prior to placing shall be free of loose or extraneous material and sharp objects that may damage the filter fabric during installation. Adjacent rolls of the fabric shall be overlapped a minimum of 450 mm. The preceding roll shall overlap the following roll in the direction the material is being spread.

Damage to the fabric resulting from Contractor's vehicles, equipment or operations shall be replaced or repaired by the Contractor at his Cost.

Drain Outlet

The outlet for a sub-surface drain shall not be under water or plugged with debris but should be a free outlet discharging into a stream, culvert or open ditch. The bottom of the pipe shall be kept above high water level in the ditch and the end protected with a grate or screen. For a length of 500 mm from the outlet end, the trench for pipe shall not be provided with granular material but backfilled with excavated soil and thoroughly compacted so as to stop water directly percolating from the backfill material around the pipe. The pipe in this section shall not have any perforations.

Aggregate Drains

Aggregate drains shall be placed within the verge/shoulders after completion of the pavement. Depth, thickness and spacing of the aggregate drains shall be as shown on the drawings.

Trenches for aggregate drains shall be excavated to a minimum width of 300 mm and to the depth shown on the drawings or ordered by the Engineer. The bottom of the trench shall be sloped to drain and shall be free from loose particles of soil. The trench shall be excavated so as to expose clearly the granular pavement courses to be drained.

Aggregate for the drains shall be durable gravel, stone or slag and shall be free from vegetable matter and other deleterious substances. The grading requirements are given in Table 300-4. Grading to be adopted shall be indicated in the drawings.

Table 300-4 : Grading Requirements for Aggregate Drains

Sieve Designation	Percent Passing by Weight	
	Type A	Type B
63 mm	-	100
37.5 mm	100	85 – 100
19 mm	-	0 – 20
9.5 mm	45 – 100	0 – 5
3.35 mm	25 – 80	-
600 micron	8 – 45	-
150 micron	0 – 10	-
75 micron	0 – 5	-

Measurements for Payment

Measurement for surface and sub-surface drains shall be per running metre length of the drain.

Rates

The Contract unit rates for surface and sub-surface drains shall be payment in full for all items such as excavation, dressing the sides and bottom; providing lining, turving, pitching, masonry, concrete and plastering; providing, laying and jointing pipes including wrapping with geosynthetic fabric; providing, laying and compacting backfill around the pipe, granular bedding; providing, fixing and painting of cover etc. including full compensation for all materials, labour, tools, equipment and other incidentals to complete the work as shown on drawings with all leads and lifts including removal of unsuitable material. Provision of inlets, gratings, sumps, outlet pipes, bedding, disburers etc. wherever required shall be incidental to construction of drain.

310 PREPARATION AND SURFACE TREATMENT OF FORMATION

Preparation and surface treatment of the formation, shall be carried out only after completion of any specified sub-grade drainage and unless otherwise agreed by the Engineer, immediately prior to laying the sub-base or the road base where no sub-base is required. The sequence of operations shall be as follows:

- a) Full formation, after reinstatement of any soft areas to the required Specifications shall be well cleaned and freed of all mud and slurry.
- b) The surface shall be compacted to the required density by a smooth wheeled roller of 80 to 100 kN weight after spraying requisite amount of water, if required.
- c) the formation shall be finished to the requirements of Clause 305.3.9.

The entire work of surface treatment of formation shall be deemed as incidental to the work of sub-base/base course to be provided for the same.

311 WORKS TO BE KEPT FREE OF WATER

The Contractor shall arrange for the rapid dispersal of water collected/ accumulated on the earthwork or completed formation during construction or on the existing roadway or which enters the earthwork or any other item of work from any source, and where practicable, the water shall be discharged into the permanent outfall of the drainage system. The arrangements shall be made in respect of all earthwork including excavation for pipe trenches, foundations or cuttings.

The Contractor shall provide, where necessary, temporary water courses, ditches, drains, pumping

or other means for maintaining the earthwork free from water. Such provisions shall include carrying out the work of forming the cut sections and embankments in such manner that their surfaces have at all times a prescribed crossfall and, where practicable, a sufficient longitudinal gradient to enable them to shed water and prevent ponding.

The works involved in keeping the earthwork or any other item of works free of water shall be deemed as incidental to the respective item of work and as such no separate payment shall be made for the same.

312 WATER COURSES AT CULVERTS

Excavation carried out in the diversion, enlargement, deepening or straightening water courses at culverts, where necessary, shall include the operations such as clearing, grubbing, removal of vegetation, trimming of slopes, grading of beds, disposal of excavated materials, pumping, timbering etc. necessary for dealing with the flow of water.

The beds and sloping sides of water courses shall, where shown on the drawings, be protected against the action of water by rubble paving to form a flat or curved surface as indicated. The protection shall consist of large smooth faced stones or of blocks of precast concrete. Stones for rubble paving shall be roughly dressed square. No stone shall be less than 225 mm in depth nor less than 0.02 cu.m in volume and no rounded boulders shall be used. After completion of construction of culverts, temporary diversion of water course, if any, shall be closed and water course restored for flow through the culvert as per the direction of the Engineer.

Measurements for Payment

The work for water courses at culverts as stated above shall be measured in terms of units specified in the Bill of Quantities for respective items. The temporary diversion of channel to facilitate construction of culverts, its closure and restoration to original water course shall be

Earthwork, Erosion Control and Drainage

Section 300

considered incidental to the work of construction of culverts and no extra payment shall be made for the same.

Rates

The Contract unit rates for different items of water courses at culverts shall be payment in full for carrying out all required operations including full compensation for all cost of materials, labour, tools, equipment and other incidentals to complete the work to the Specifications.

313 ROCKFILL EMBANKMENT

Scope

The work covers embankment constructed with pieces of rock and shall be in accordance with the lines, grades and cross-sections as shown in drawings or as directed by the Engineer.

There shall be a minimum of 500 mm thick earthen cushion over the rockfill. The construction of earth fill/ subgrade does not form part of scope of this work.

Materials

The size of rock pieces used in rockfill embankments shall be such that they can be deposited in layers so as to suit the conditions evaluated in the field compaction trials or as directed by the Engineer. The rockfill shall consist of hard, durable and inert material, preferably maximum size not exceeding 300 mm and percent finer than 125 mm not exceeding 10 percent.

Argillaceous rocks (clay, shales etc.), unburnt colliery stock and chalk shall not be used in rockfill.

The rock fragments and blinding material required for filling the voids shall also satisfy the above requirements.

Spreading and Compaction

The material shall be tipped, spread and levelled in layers extending to the full width of embankment by a suitable dozer. Fragments of rock shall then be spread on the top of layer to the required extent and layer compacted by minimum of 5 passes of vibratory roller having static weight 8-10 tonnes. The compacted thickness of each layer shall not exceed 500 mm. After compaction of each layer, the surface voids shall be filled with broken fragments. Next layer, where required, shall be placed in the same manner, above the earlier compacted layer.

The top layer of rockfill, on which normal earth fill will rest shall be thoroughly blinded with suitable granular material to seal its surface

Measurements for Payment

Measurement shall be made by taking cross-sections at intervals in the original position before the work starts and after its completion and computing the volume in cu.m by the method of average end areas.

Rate

The Contract unit rate shall be paid in full for carrying out all the above operations including cost of rockfill, broken fragments and blinding material and shall provide full compensation for all items as per clause 305.8.

314 GROUND IMPROVEMENT FOR WEAK EMBANKMENT FOUNDATION USING GEOSYNTHETIC DRAINS AND STONE COLUMNS

Scope

The scope for improving the ground of problematic sub-soil conditions comprises of several alternatives and combination of more than one of the following alternatives. The improvement may be chosen based on the sub-soil conditions :

- i) Using geosynthetic drains [Prefabricated Vertical Drain (PVD)] with surcharge involving design and installation of PVD to achieve 90% consolidation of sub-soil within a prescribed time.
- ii) Rammed stone columns.
- iii) Stone columns formed by vibroflot technique.

Where specified in the Contract the scope of the work shall also cover the design of the ground improvement works by the Contractor.

Prefabricated Vertical Drain (PVD) with Surcharge

The design and construction of this drain shall generally comply with the requirements of IS:15284 (Part 2) and the requirements given below. In the case of conflict between the requirements of IS:15284 and this Specification, the requirements of this Specification shall prevail.

Materials

- i) **Geosynthetic Drain:** Geosynthetic strip or band drain shall be manufactured by an ISO 9001 certified manufacturer. It shall consist of a corrugated or studded or 3-d mesh consisting of an inner core of thick polyester fused at intersection, wrapped in a non-woven geotextile. Band drain shall be of width and thickness as specified in the design and shall be a minimum of 100 mm width and 5 mm thickness. The core shall serve as the drainage medium conveying the core water from the soft subsoil to the drainage layer at the top. The core shall be of three-dimensional mesh, made of polyester or equivalent. The filter should be non-woven needle punched adhesive-bonded fabric. The filter and the core shall be ultrasonically welded together at edges to produce a fully integrated product. The drain shall meet the properties specified in Table 700-3.

The drains shall be installed to depths and at spacing as per the design and drawings. The Contractor shall submit to the Engineer the complete scheme for installation of vertical band drains along with the particulars and test results from the manufacturer showing conformance to the specifications. Unless specified otherwise, the design of the ground improvement measures shall be to achieve 90 percent consolidation in the time prescribed by the employer. The equipment and the methodology for installation of the drains shall satisfy the specified requirement of prescribed degree of consolidation and the time for achieving the same.

- ii) **Granular Sand Blanket :** After installation of the vertical band drains in the sub-soil, a blanket of well draining granular material/coarse sand (natural or crushed) conforming to Class I grading given in Table 300-4 of specified thickness compacted to a density of 75 to 80 percent of maximum dry density obtained by heavy compaction (IS:2720-Part 8) shall be provided. The granular sand blanket shall be exposed to atmosphere at its periphery for dissipation of pore water pressure
- iii) **Geotextile Fabric for Separation and Drainage :** The requirements of synthetic geotextile shall be as given in Table 700-1.

Construction and Installation Requirements

- i) **Shipment and Storage :** The Geosynthetic Band Drain shall be dry and wrapped such that it is protected from the exposure to ultraviolet light during shipping and storage. At no time shall the band drain be exposed to ultraviolet light for a period exceeding fourteen days. If stored outdoor, they shall be elevated and protected with a waterproof

cover. The Geo-synthetic Band Drain shall be labeled as per ASTM D 4873, "Guide for identification, storage, and handling of geotextile.

- ii) **Drain Installation** : Band Drains in roll shall be installed using an installation rig/sticher mounted on a base machine (Hydraulic or Mechanical). The end of the drain shall be attached to a hollow rectangular mandrel or shoe, which will be driven into the soft clay by appropriate mechanism, such as lance. On reaching the refusal strata (stiff soil), the mandrel with the drain shall be left behind and the lance withdrawn. The top of the drain above the ground level shall be cut off at design level (150 mm into the drainage blanket). The rig/ sticher moves on to the next location.
- iii) After installation of vertical band drains, a blanket of granular coarse sand as mentioned above shall be spread over the entire area and covered with geotextile layer on top and bottom as directed by the Engineer.
- iv) **Installation of geotextile fabric for separation and drainage** :
 - a) **Shipment and Storage** : The geotextile shall be kept dry and wrapped such that it is protected from the exposure to ultraviolet light during shipping and storage. At no time shall the paving fabric be exposed to ultraviolet light for a period exceeding fourteen days. Geotextile rolls shall be stored in a manner, which protects them from elements. If stored outdoor, they shall be elevated and protected with a waterproof cover. The geotextile shall be labeled as per ASTM D 4873, "Guide for identification, storage and handling of geotextiles".
 - b) **Fabric Placement** : The geotextile shall be laid smooth without wrinkles or folds on the sand blanket in the direction of construction traffic. Adjacent geotextile rolls shall be overlapped, sewn or jointed, (Preferably sewn or joined). On curves the geotextile may be folded or cut & overlap to conform to the curves. The fold or overlap shall be in the direction of construction and held in place by pins, staples, or piles of fill or rock. Prior to covering, the geotextile shall be inspected by the Engineer to ensure that the geotextile has not been damaged (i.e. holes, tears, rips) during installation. Damaged geotextiles, as identified by the Engineer, shall not be allowed. The surcharge shall be placed such that at least the minimum specified lift thickness shall be between the geotextile and the equipment tyres or tracks at all times. Turning of vehicles shall not be permitted on the first lift above the geotextile.

- c) **Seaming** : A sewn seam is to be used for the seaming of the geotextile. The thread used shall consist of high strength polypropylene or polyester. Nylon thread shall not be used. The thread shall also be resistant to ultraviolet radiation. The thread shall be of contrasting color to that of the geotextile itself. For seams which are sewn in the field, the Contractor shall provide at least a 2 m length sewn seam for sampling by the Engineer before the geo-textile is installed. For seams which are sewn in the factory, the Engineer shall obtain samples of the factory seams at random from any roll of geotextile which is used on the project. For seams that are field sewn, the seams sewn for sampling shall be sewn using the same equipment and procedures as will be used for the production seams. If seams are sewn in both the machine and cross machine direction, samples of seams from both directions shall be provided. The seam assembly descriptions shall be submitted by the Contractor along with the sample of the seam. The description shall include the seam type, stitch type, sewing thread and stitch density.
- v) **Addition of Surcharge** : Addition of surcharge load by approved embankment material shall be placed over the geotextile layer upto a height as per the design requirement. The addition of surcharge shall be placed with adequate side slope to avoid any slope failure. The addition of surcharge shall be kept in place for a period as per the design to achieve desired degree of consolidation. After ascertaining that the desired degree of consolidation is achieved, the addition of surcharge which is not forming part of permanent work/ embankment shall be removed to the required level as per drawings. Removal of additional surcharge material shall be done without damaging the road embankment. After removal of additional surcharge, the damaged embankment top, if any, shall be made good as instructed by the Engineer. The addition and removal of surcharge shall be incidental to the work except for payment of additional surcharge quantity forming part of permanent embankment. The quantity for payment will be determined based on the settlements readings observed through instrumentation.
- vi) **Instrumentation and Monitoring the Behaviour of Sub-Soil/ Embankment** : Monitoring the behavior of the sub-soil/ embankment construction shall form part of the work. The design shall be based on the gain in the shear strength of the subsoil due to consolidation process. The following critical parameters shall be monitored :
- a) **Monitoring the Build up and Dissipation of Pore Pressure:**
Casagrande open standpipe type piezometers shall be used for

the measurement of changes in pore pressure. The specifications for the Casagrande piezometer shall be as follows.

The piezometer shall be 38 mm in dia and 300 mm in length; The air entry value shall be of the order of 0.3 kg/cm².

The standpipe shall be more than 16 mm in diameter;

The piezometer shall be installed in 150 mm borehole, at specified depths. Sand cover around the piezometer tip and bentonite seal above shall be provided; and

Suitable electronic sensor shall be used to record the water level. Piezometers including dummy piezometers shall be installed at locations specified by the Engineer.

- b) **Rate and Magnitude of Vertical Settlements of the Subsoil under the Surcharge Load** : Settlements shall be measured by installing platform type settlement gauges, which consist of the following :

Wooden base plate 1000 mm square and 50 mm thick;

GI pipe of 25 mm dia fitted to the base plate with a suitable sleeve arrangement and nuts and bolts;

Outer loose fitting sleeve, to prevent soil from coming into contact with the inner pipe;

The pipe and the sleeve consist of 1.5 m long sections, which can be screwed on at the top, so that as the surcharge is built up, the top of the pipe is well clear of the fill;

Settlement gauges shall be installed at the ground level, before the starting of the fill construction. These shall be installed at locations specified by the Engineer. The readings of settlement gauges also form the basis to estimate the quantity of surcharge forming part of permanent work. The number of settlement gauges shall be decided by the Engineer keeping in view this aspect.

- c) **Measurement of Shear Strength** : The shear strength parameters of the subsoil [unconfined compressive strength (UCS)] shall be measured at locations specified by the Engineer at the end of each stage of surcharge loading in order to compare the actual details with the design assumptions. For the recovery of undisturbed samples from the subsoil for determining UCS, before start of construction of surcharge, 100 mm dia casing pipe shall be installed into the ground to 3 m depth, preferably by driving; the top of the casing pipe shall have provision for adding extensions

at top by screw coupling; and as the surcharge construction proceeds the casing pipe shall be extended. This procedure ensures avoiding drilling through the surcharge already placed as well as any damage to the installed band drains. Undisturbed samples (UDS) are recovered and UCS is determined in the site laboratory (sending UDS sample to distant laboratories would result in loss of water content and disturbance of the samples leading to erroneous values of UCS). Undisturbed samples shall be recovered at every 1.5 m depth at the specified locations, so that complete strength profile of subsoil is obtained.

- vii) During the placing of the surcharge and compaction, the Contractor shall take utmost care so that the monitoring instruments are not damaged. Compaction by small vibratory rollers shall be done for 1.5 m around the monitoring instruments and bigger rollers shall not be used near the monitoring instruments. Similarly care shall be taken that movement of dumpers does not damage the monitoring instruments.
- viii) **Frequency of Observations** : The readings of the piezometers and the settlement gauges shall be recorded at the following frequency.
 - a) Daily reading shall be taken in stretches where filling/ surcharge operations are in progress. Weekly readings shall be taken in stretches, where no filling/ surcharge is being done.
 - b) Weekly readings shall be taken after the desired fill/ surcharge height is achieved, till the next stage filling commences. All data shall be recorded in a register and maintained properly.
 - c) The Data from the monitoring instruments provides the background for regulating the rate of placing the fill/ surcharge as well as the waiting period between stages.
- ix) **Precautions against Pilferage**: The observation data shall be recorded during construction and for three months thereafter. It is therefore essential that the instruments are not tampered and stolen. Suitable precautions shall be taken in this regard by the Contractor.
- x) **Drainage of Ground Water** : The water which will come out from the subsoil through vertical drains will be accumulated at temporary ditches to be dug at nearby areas and the accumulated water will be dewatered regularly from the ditches to the outfalls as directed by the Engineer.
- xi) **Certification from the Manufacturer of Band Drain and Geotextile Fabric for Separation and Drainage** :
 - a) The Contractor shall provide to the Engineer, a certificate stating the name of the manufacturer, product name, style number, chemical

composition of the filament or yarns and other pertinent

information to fully describe the material. Each roll shall be labelled or tagged to protect product identification as well as inventory and quality control.

- b) The manufacturer shall be responsible for establishing and maintaining a quality control programme to assure compliance with the requirement of the specification. Documentation describing the quality control programme shall be made available upon request.
- c) The manufacturer's certificate shall state that the furnished material meets minimum averages roll values (MARV) requirements of the specifications as evaluated under the Manufacturer's quality control programme. The certificate shall be attested by a person having legal authority to bind the Manufacturer.

Measurements for Payment

- i) The Geosynthetic Band Drains (or geodrain) shall be measured in linear metre of its length.
- ii) The granular sand blanket shall be measured in cubic metre.
- iii) The geo-synthetic fabric shall be measured in square metre of plan area of final finished work.
- iv) Instrumentation and monitoring the behaviour of sub-soil/ embankment shall be measured in number of locations.
- v) The additional surcharge quantity forming part of permanent embankment shall be measured in cum.

The overlaps, patches, sewn seams and securing pins shall not to be measured.

Rate

Rate shall include cost of design, materials, installation, operations involved in pre-loading/ additional surcharge, dewatering, labour, plant hire, material storage and handling expenses for completing the work including submission of construction drawings and provision of specialist attendance & supervision at site for (i) geodrain; (ii) sand blanket; (iii) geofabric;

(iv) instrumentation and monitoring; and (v) permanent embankment part of surcharge as described above.

Rammed Stone Columns using Non-Displacement Method of Construction

The design and construction of this column shall generally comply with the requirements of IS:15284 (Part 2), including the requirements given below. In the case of conflict between the requirements of IS:15284 and these Specifications the requirements of these Specifications shall prevail.

Stone columns shall be formed from well-graded crushed stone and gravel compacted to a dense state. The size of the well graded crushed aggregate shall vary from 2 mm to 75 mm conforming to the gradation given below.

Size of the Crushed Aggregate	% Passing
75 mm	90-100
50 mm	80-90
38 mm	55-75
20 mm	10-20
12 mm	5-13
2 mm	5

The crushed aggregate shall be chemically inert, hard and resistant to breakage. The diameter of the stone columns shall be as shown in the drawings.

Granular Blanket

A compacted and well draining layer of gravel or coarse sand, of specified thickness, compacted in layers to a relative density of 75 to 80 percent shall be provided above the existing ground. This blanket shall be exposed to atmosphere at its periphery for pore water pressure dissipation.

Construction and Installation Requirements

The “Rammed Stone Columns” shall be constructed by non-displacement technique namely “Bailer and Casing Method” as given in IS:15284 (Part 1). After ensuring complete removal of slush deposited during boring operations, a minimum depth of 0.5 m, preferably 0.75 below the granular blanket shall be compacted by other suitable means such as rolling/ tamping to the specified densification criteria.

Field Controls

In the above method, the following minimum field controls shall essentially be observed. The set criteria and the consumption of granular fill form the main quality control measure for the columns constructed by the non-displacement technique. The set criteria shall be established as given in IS:15284 (Part 1). For ascertaining the consumption of fill, the diameter of the column as formed during field trials shall be measured in its uppermost part along the four diameters and average of these observations taken as the column diameter.

Field Loading Tests

Initial and routine tests shall be carried out as given in IS:15284 (Part 1).

Recording of Data shall be done as given in IS:15284 (Part 1).

Load Test Results

The ultimate load capacity of single column shall be determined from load tests. The settlement of a stone column obtained at safe/ working load from load test results on a single column shall not be directly used in forecasting the settlement of the structure unless experience from similar foundations in similar soil conditions on its settlement behaviour is available. The average settlement may be assessed on the basis of sub-soil data and loading details of the structures as a whole using the principles of soil mechanics.

Certification

The Contractor shall be responsible for establishing and maintaining a quality control programme to assure compliance with the requirements of the specifications.

Measurement for Payment

- i) The rammed stone column of the specified diameter shall be measured in linear metre of its compacted length.
- ii) The sand blanket shall be measured in cu.m.
- iii) The initial and routine load tests, unless otherwise specified in the contract, shall be measured in numbers and paid.

Rate

The rate shall include the cost of providing all materials, tools, equipment, labour, supervision and incidentals necessary to complete the work as per these specifications.

Stone Columns using Vibro-replacement (Vibroflot) Method of Construction

Scope

The scope of the work shall consist of:

- i) construction of stone columns, complete in-place including layout;
- ii) supplying crushed stone, equipment, electrical power, water and any other necessary items for stone column and its installation;
- iii) Control and disposal of surface water resulting from stone column construction operations;
- iv) Construction and removal of silt settling ponds or similar facilities as required, and the regrading of the site as required;
- v) Stockpiling and disposal of silt from the site if necessary; and
- vi) Load testing of stone columns as specified

The design and construction of stone columns shall comply with IS:15284 (Part I) subject to certain modifications incorporated in these Specifications or any other modification suggested by the Engineer. The construction of sand (or stone) working platform and necessary access to site shall not form part of the scope of this work. Stone Column with maximum compacted density shall extend to the full depth of the compressible stratum and reach the Dense Sand Layer/Stiff Clay Layer.

The Contractor shall (i) meet all applicable laws and regulations concerning surface runoff, siltation, pollution and general disposal of the effluent from the construction of the stone columns and general site work, (ii) construct and relocate temporary ditches, swales, banks, dams, and similar facilities as necessary to control the flow of surface water during the work, remove them when no longer required, and regrade the affected areas for acceptable drainage as specified for site grading, (iii) construct silt settling ponds as required in locations indicated or approved, ensure that earth banks and water control devices are safely designed and prevent inadvertent discharge into watercourses off the site, stockpile and dispose of all silt as approved by the Engineer, (iv) remove settling ponds and other structures when no longer required and regrade the areas for acceptable drainage as specified for site grading.

Materials

- a) **Stone Aggregate for Compacted Column** : The crushed stone and gravel for column backfill shall be clean, hard, angular, chemically inert, resistant to breakage and free from organic, trash, or other deleterious materials. It shall be well-graded stones of 75 mm down to 2 mm size. The uniformity coefficient shall be greater than 3. The Aggregate Impact Value shall not be more than 30 percent.
- b) **Drainage Blanket** : Sand/crushed stone, which is hard, inert, resistant to chemical change and free from organic, trash, or other deleterious materials shall only be used in drainage blanket. The blanket shall be well graded and free draining granular material of thickness 500 mm or more, compacted in layers to a relative density of 75 to 80 percent. This blanket shall be exposed to atmosphere at its periphery for pore water pressure dissipation.

Construction and Installation

The stone columns shall be installed by Vibroflot method given in IS:15284 (Part 1). Stone shall be fed by mechanical means i.e. use of loader/ hopper/ chute etc. The slush, muck and other loose materials at work site shall be removed/ disposed off suitably by the Contractor as instructed by the Engineer. The Contractor shall take adequate measures to ensure stability of bore holes made for installation of stone column.

A detailed installation procedure/method statement shall be submitted by the Contractor including:

- i) Type and number of Vibroflots and general method of operation including construction schedule.
- ii) Mechanical arrangement for placing stones (s) around the probe point
- iii) Quality control, Quality Assurance Procedure covering details on automatic recording devices to monitor and record stone consumption
- iv) Type of equipment to be deployed
- v) Manpower to be engaged
- vi) The proposed sequence and timing for constructing stone columns along with a bar chart for the entire ground improvement work.

Stone column installation procedure shall be as approved by the Engineer. The construction technique and probe shall be capable of producing and/or complying with the following:

- i) The holes shall be close to circular.

- ii) The probe and follower tubes shall be of sufficient length to reach the elevations shown on the plans. The probe, used in combination with the flow rate and available pressure to the tip jet, shall be capable of penetrating to the required tip elevation. Preboring of stiff lenses, layers or strata is permitted.
- iii) The probe shall have visible external markings at suitable increments to enable measurement of penetration and re-penetration depths
- iv) Sufficient quantity of wash water shall be provided to the tip of the probe to widen the probe hole to a diameter to allow adequate space for stone backfill placement around the probe. The flow of water from the bottom jet shall be maintained at all times during backfilling to prevent caving or collapse of the hole and to form a clean stone column. The flow rate will generally be greater as the hole is jetted in, and decrease as the stone column comes up
- v) After forming the hole, the vibrator shall be lifted up a minimum 3 m, dropped at least twice to flush the hole out. The probe shall not, however, be completely removed from the hole
- vi) The column shall be formed by adding stone in lifts having each lift height between 600 cm and 1000 cm. The stone aggregate in each lift shall be compacted by re-penetrating it at least twice with the horizontally vibrating probe so as to densify and force the stone radially into the surrounding in-situ soil. The stone in each increment shall be re-penetrated a sufficient number of times to develop a minimum ammeter reading on the motor of at least 40 amps more than the free-standing (unloaded) ampere draw on the motor, but no less than 80 amps total
- vii) Stone columns shall be installed so that each completed column will be continuous throughout its length

Data captured shall be continuously displayed on a LCD unit and graphical output (plots of depth versus time and power consumption) generated by automated computerized recording device throughout the process of stone column installation for each point shall be submitted to the Engineer.

The equipment to be used shall be instrumented with sensors and the data processed by a micro-processing unit to enable continuous monitoring and data capture of the following during construction of each stone column:

- a) depth of vibrator and vibrator movements (depth of penetration)
- b) power consumption (compaction effort)

If erosion of upper granular working platform material occurs, the depression shall be backfilled with

sand/ granular material which meets the specification for the working platform. Such backfilling shall be at the Contractor's expense. The working surface shall be cleaned at the completion of the stone column construction of all unsuitable materials washed up from the stone column holes. Such unsuitable materials include clay or silt lumps, wood fragments or other organic matter. If, in the opinion of the Engineer, these materials create "soft spots" or zones of compressibility or weakness in connection with the placement of overlying embankment materials, such unsuitable materials shall be disposed of in a manner approved by the Engineer

In the event of obstructions preventing the penetration of the Vibrofloat, the Contractor shall stop work, move to another compaction point and immediately notify the Engineer. The Engineer may at his option authorize one or several of the following:

(i) position the compaction point a short distance away from the original position, (ii) additional compaction points to bridge the obstruction, (iii) remove the obstruction, replace removed soils, and again jet the column hole in the indicated location, (iv) perform other removal or relocation operations or (v) any other method.

Field Controls

In the above method, the following minimum field controls shall be observed.

- a) Vibrofloat penetration depth including the depth of embedment in firm strata.
- b) Monitoring of volume of backfill added to obtain an indication of the densities achieved, and
- c) Monitoring of ammeter or hydraulic pressure gauge readings to verify that the maximum possible density has been achieved in case of Vibrofloat columns.

Recording of Data shall be done as given in IS:15284 (Part 1).

Field Loading Tests

The Initial load tests shall be performed at a trial test site approved by the Engineer to evaluate the load-settlement behaviour of the soil-stone column system. The tests shall be conducted on a single and also on a group of minimum three columns in accordance with IS:15284 (Part-1). The number of initial tests shall be as follows:

Single column tests – 1 test per 500 or part thereof stone columns.

Three column group tests – 1 test per 1000 or part thereof stone columns.

The Routine load tests shall be carried out on a single job column in accordance with IS:15284 (Part-1). The job columns shall be loaded for a test load of

1.1 times the design load intensity with kentledge minimum 1.3 times the design load pattern.

The number of routine tests shall be as follows:

Single column tests – 1 test per 500 or part thereof stone columns.

The test load shall be applied at increments of one-tenth to one-fifth of the design load upto a maximum of 1.5 times the design load. Each load stage shall be maintained till the settlement rate is less than 0.1 mm/30 min.

The test load shall be maintained for a minimum period of 24 hours. The ultimate load on the stone column shall be determined by double tangent diagram. The test load shall be removed in five to six stages. Each unloading stage shall be maintained till the rebound attains a rate of 2.0 mm/30 min.

Safe and efficient working of the loading arrangements is entirely the Contractor's responsibility and any impediment resulting in the failure of the test arrangement may debar the Contractor from payment for the test. Alternatively, it may make the Contractor liable to repeat the test on separate column/columns without any extra cost.

The construction of stone columns shall be carried out using the same procedure as adopted for the test column to the satisfaction of the Engineer. The stone columns under the test shall be a part of a larger stone column group. The interpretation of the results shall be free from ambiguity and shall be subject to the Engineer's approval. No work shall proceed unless the Contractor shall satisfy the Engineer beyond reasonable doubt that the performance of the stabilized soil material will be compliant with the Specification.

Tolerances

Setting Out

Setting out shall be carried out from reference lines and points shown in the drawings. Immediately before installation of the stone columns, the stone column positions shall be marked with suitable identifiable markers.

Position

No vibration center or stone column shall be more than 150 mm off its correct center location in any direction at the working platform level as shown on the approved plans.

Verticality

Stone Columns shall be constructed as vertical as possible. The axis of the stone column shall not be inclined from the vertical by more than 1h: 20v as indicated by the tilt of vibrator and follower tubes.

Personnel

The Contractor shall employ suitable personnel having experience in the construction of stone columns.

Quality Control

The Contractor shall establish and maintain a quality control programme to assure compliance with the requirements of the specifications.

Measurements for Payment

- i) The stone column by Vibrofloat method shall be measured in linear metre of its compacted length.
- ii) The sand blanket shall be measured in cum.
- iii) The initial and routine load tests, unless otherwise specified in the Contract, shall be measured in numbers and paid.

Rate

The rate shall include the cost of providing all materials, tools, equipment, labour, supervision and incidentals necessary to complete the work as per these Specifications.

400

SUB-BASES, BASES (NON-BITUMINOUS) AND SHOULDERS

Scope

This work shall consist of laying and compacting well-graded material on prepared sub grade in accordance with the requirements of these Specifications. The material shall be laid in one or more layers as sub-base or lower sub-base and upper sub-base (termed as sub- base hereinafter) as necessary according to lines, grades and cross-sections shown on the drawings or as directed by the Engineer.

Materials

The material to be used for the work shall be natural sand, crushed gravel, crushed stone, crushed slag, or combination thereof depending upon the grading required. Use of materials like brick metal, Kankar and crushed concrete shall be permitted in the lower sub-base. The material shall be free from organic or other deleterious constituents and shall conform to the grading given in Table 400-1 and physical requirements given in Table 400-2. Grading III and IV shall preferably be used in lower sub-base. Grading V and VI shall be used as a sub-base-cum-drainage layer. The grading to be adopted for a project shall be as specified in the Contract. Where the sub-base is laid in two layers as upper sub-base and lower sub-base, the thickness of each layer shall not be less than 150 mm.

If the water absorption of the aggregates determined as per IS:2386 (Part 3) is greater than 2 percent, the aggregates shall be tested for Wet Aggregate Impact Value (AIV) (IS:5640). Soft aggregates like Kankar, brick ballast and late rite shall also be tested for Wet AIV (IS:5640).

Table 400-1 : Grading for Granular Sub-base Materials

IS Sieve Designation	Percent by Weight Passing the IS Sieve					
	Grading I	Grading II	Grading III	Grading IV	Grading V	Grading VI
75.0 mm	100	-	-	-	100	-
53.0 mm	80-100	100	100	100	80-100	100
26.5 mm	55 -90	70-100	55-75	50-80	55-90	75-100
9.50 mm	35-65	50-80	-	-	35-65	55-75
4.75 mm	25 - 55	40-65	10-30	15-35	25-50	30-55
2.36 mm	20- 40	30-50	-	-	10-20	10-25
0.85 mm	-	-	-	-	2-10	-

0.425 mm	10-15	10- 15	–	–	0-5	0-8
0.075 mm	<5	< 5	< 5	< 5	–	0-3

Table 400-2 : Physical Requirements for Materials for Granular Sub-base

Aggregate Impact Value (AIV)	IS:2386 (Part 4) or IS:5640	40 maximum
Liquid Limit	IS:2720 (Part 5)	Maximum 25
Plasticity Index	IS:2720 (Part 5)	Maximum 6
CBR at 98% dry density (at IS:2720-Part 8)	IS:2720 (Part 5)	Minimum 30 unless otherwise specified in the Contract

Construction Operations

Preparation of Sub-grade

Immediately prior to the laying of sub-base, the sub grade already finished to Clause 301 or 305 as applicable shall be prepared by removing all vegetation and other extraneous matter,lightly sprinkled with water, if necessary and rolled with two passes of 80–100 KN smooth wheeled roller.

Spreading and Compacting

The sub-base material of the grading specified in the Contract and water shall be mixed mechanically by a suitable mixer equipped with provision for controlled addition of waterand mechanical mixing. So as to ensure homogenous and uniform mix. The required water content shall be determined in accordance with IS:2720 (Part 8). The mix shall be spread onthe prepared sub grade with the help of a motor grader of adequate capacity, its blade havinghydraulic controls suitable for initial adjustment and for maintaining the required slope and grade during the operation, or other means as approved by the Engineer.

Moisture content of the mix shall be checked in accordance with IS:2720 (Part 2) and suitablyadjusted so that, at the time of compaction, it is from 1 to 2 percent below the optimum moisture content.

Immediately after spreading the mix, rolling shall be done by an approved roller. If the thickness of the compacted layer does not exceed 100 mm, a smooth wheeled roller of 80 to 100 kN weight may be used. For a compacted single layer upto 200 mm the compaction shall be done with the help of a vibratory roller of minimum 80 to 100 KN static weight capable of achieving the required compaction. Rolling shall commence at the lower edge and proceed towards the upper edge

longitudinally for portions having unidirectional cross fall or on super-elevation. For carriageway having cross fall on both sides, rolling shall commence at the edges and progress towards the crown. Each pass of the roller shall uniformly overlap not less than one-third of the track made in the preceding pass. During rolling, the grade and cross fall (camber) shall be checked and any high spots or depressions which become apparent, corrected by removing or adding fresh material. The speed of the roller shall not exceed 5 km per hour.

Rolling shall be continued till the density achieved is at least 98 percent of the maximum dry density for the material determined as per IS:2720 (Part 8). The surface of any layer of material on completion of compaction shall be well closed, free from movement under compaction equipment and from compaction planes, ridges, cracks or loose material. All loose, segregated or otherwise defective areas shall be made good to the full thickness of layer and re-compacted.

Surface Finish and Quality Control of Work

The surface finish of construction shall conform to the requirements of Clause 902. Control on the quality of materials and works shall be exercised by the Engineer in accordance with Section 900.

Arrangements for Traffic

During the period of construction, arrangements for the traffic shall be provided and maintained in accordance with Clause 112.

Measurements for Payment

Granular sub-base shall be measured as finished work in position in cubic meters.

The protection of edges of granular sub-base extended over the full formation as shown in the drawing shall be considered incidental to the work of providing granular sub-base and as such no extra payment shall be made for the same.

Rate

The Contract unit rate for granular sub-base shall be payment in full for carrying out the required operations including full compensation for:

- i) making arrangements for traffic to Clause 112 except for initial treatment to verges, shoulders and construction of diversions;
- ii) supplying all materials to be incorporated in the work including all royalties, fees, rents where applicable with all leads and lifts;
- iii) all labour, tools, equipment and incidentals to complete the work to the

Specifications;

- iv) carrying out the work in part widths of road where directed; and
- v) carrying out the required tests for quality control.

402 LIME TREATED SOIL FOR IMPROVED SUB-GRADE/SUB-BASE

Scope

This work shall consist of laying and compacting an improved sub-grade/lower sub-base of soil treated with lime on prepared sub-grade in accordance with the requirements of these Specifications and in conformity with the lines, grades and cross-sections shown on the drawings or as directed by the Engineer. Lime treatment is generally effective for soils which contain a relatively high percentage of clay and silty clay.

Materials

Soil

Except when otherwise specified, the soil used for stabilization shall be the local clayey soil having a plasticity index greater than 8.

Lime

Lime for lime-soil stabilization work shall be commercial dry lime slaked at site or pre-slaked lime delivered to the site in suitable packing. Unless otherwise permitted by the Engineer, the lime shall have purity of not less than 70 percent by weight of Quick-lime (CaO) when tested in accordance with IS:1514. Lime shall be properly stored to avoid prolonged exposure to the atmosphere and consequent carbonation which would reduce its binding properties.

Quantity of Lime in Stabilized Mix

Quantity of lime to be added as percentage by weight of the dry soil shall be as specified in the Contract. The quantity of lime used shall be related to its calcium oxide content which shall be specified. Where the lime of different calcium oxide content is to be used, its quantity shall be suitably adjusted with the approval of the Engineer so that equivalent calcium oxide is incorporated in the work. The mix design shall be done to arrive at the appropriate quantity of lime to be added, having due regard to the purity of lime, the type of soil, the moisture-density relationship, and the design CBR/Unconfined Compressive Strength (UCS) value specified in the Contract. The laboratory

CBR/UCS value shall be at least 1.5 times the minimum field value of CBR/UCS stipulated in the Contract.

Water

The water to be used for lime stabilisation shall be clean and free from injurious substances. Potable water shall be used.

Construction Operations

Weather Limitations

Lime-soil stabilisation shall not be done when the air temperature in the shade is less than 10°C.

Degree of Pulverisation

For lime-soil stabilisation, the soil before addition of stabilizer, shall be pulverized using agricultural implements like disc harrows (only for low volume roads) and rotavators to the extent that it passes the requirements set out in Table 400-3 when tested in accordance with the method described in Appendix-3.

Table 400-3 : Soil Pulverisation Requirements for Lime Stabilisation

IS Sieve designation	Minimum percent by weight passing the IS Sieve
26.5 mm	100
5.6 mm	80

Equipment for Construction

Stabilised soil sub-bases shall be constructed by mix-in-place method of construction or as otherwise approved by the Engineer. Manual mixing shall be permitted only where the width of laying is not adequate for mechanical operations, as in small-sized jobs.

The equipment used for mix-in-place construction shall be a rotavator or similar approved equipment capable of pulverizing and mixing the soil with additive and water to specified degree to the full thickness of the layer being processed, and of achieving the desired degree of mixing and

uniformity of the stabilized material. If so desired by the Engineer, trial runs with the equipment shall be carried out to establish its suitability for work.

The thickness of any layer to be stabilized shall be not less than 100 mm when compacted. The maximum thickness can be 200 mm, provided the plant used is accepted by the Engineer.

Mix-in-place Method of Construction

Before deploying the equipment, the soil after it is made free of undesirable vegetation or other deleterious matter shall be spread uniformly on the prepared subgrade in a quantity sufficient to achieve the desired compacted thickness of the stabilised layer. Where single-pass equipment is to be employed, the soil shall be lightly rolled as directed by the Engineer.

The equipment used shall either be of single-pass or multiple pass type. The mixers shall be equipped with an appropriate device for controlling the depth of processing and the mixing blades shall be maintained or reset periodically so that the correct depth of mixing is obtained at all times.

With single-pass equipment the forward speed of the machine shall be so selected in relation to the rotor speed that the required degree of mixing, pulverisation and depth of processing is obtained. In multiple-pass processing, the prepared sub-grade shall be pulverised to the required depth with successive passes of the equipment and the moisture content adjusted to be within prescribed limits mentioned hereinafter. The lime shall then be spread uniformly and mixing continued with successive passes until the required depth and uniformity of processing have been obtained.

The mixing equipment shall be so set that it cuts slightly into the edge of the adjoining lane processed previously so as to ensure that all the material forming a layer has been properly processed for the full width.

Construction with Manual Means

Where manual mixing is permitted, the soil from borrow areas shall first be freed of all vegetation and other deleterious matter and placed on the prepared sub grade. The soil shall then be pulverized by means of crow-bars, pick axes or other means approved by the Engineer.

Water in requisite quantities may be sprinkled on the soil for aiding pulverisation. On the pulverized soil, the lime in requisite quantities shall be spread uniformly and mixed thoroughly by working with spades or other similar implements till the whole mass is uniform. After adjusting the moisture content to be within the limits mentioned later, the mixed material shall be leveled up to the required thickness so that it is ready to be rolled.

Addition of Lime

Lime may be mixed with the prepared material either in slurry form or dry state at the option of the Contractor with the approval of the Engineer.

Dry lime shall be prevented from blowing by adding water to the lime or other suitable means selected by the Contractor, with the approval of the Engineer.

The tops of windrowed material may be flattened or slightly trenched to receive the lime.

The distance to which lime may be spread upon the prepared material ahead of the mixing operation shall be determined by the Engineer.

No traffic other than the mixing equipment shall be allowed to pass over the spread lime until after completion of mixing.

Mixing or remixing operations, regardless of equipment used, shall continue until the material is free of any white streaks or pockets of lime and the mixture is uniform.

Non-uniformity of colour reaction, when the treated material is tested with the standard phenolphthalein alcohol indicator, will be considered evidence of inadequate mixing.

Moisture Content for Compaction

The moisture content at compaction checked vide IS:2720 (Part 2) shall neither be less than the optimum moisture content corresponding to IS:2720 (Part 8) nor more than 2 percent above it.

Rolling

Immediately after spreading, grading and leveling of the mixed material, compaction shall be carried out with approved equipment preceded by a few passes of lighter rollers if necessary. Rolling shall commence at edges and progress towards the centre, except at super elevated portions or for carriageway with unidirectional cross-fall where it shall commence at the inner edge and progress towards the outer edge. During rolling, the surface shall be frequently checked for grade and crossfall (camber) and any irregularities corrected by loosening the material and removing/adding

fresh material. Compaction shall continue until the density achieved is at least 98 percent of the maximum dry density for the material determined in accordance with IS:2720 (Part 8).

Care shall be taken to see that the compaction of lime stabilized material is completed within three hours of its mixing or such shorter period as may be found necessary in dry weather.

During rolling it shall be ensured that roller does not bear directly on hardened or partially hardened treated material previously laid other than what may be necessary for achieving the specified compaction at the joint. The final surface shall be well closed, free from movement under compaction planes, ridges, cracks or loose material. All loose or segregated or otherwise defective areas shall be made good to the full thickness of the layer and recomputed.

Curing

The sub-base course shall be suitably cured for a minimum period of 7 days after which subsequent pavement courses shall be laid to prevent the surface from drying out and becoming friable. No traffic of any kind shall ply over the completed sub-base unless permitted by the Engineer.

Surface Finish and Quality Control of Work

The surface finish of construction shall conform to the requirements of Clause 902.

Control on the quality of materials and works shall be exercised by the Engineer in accordance with Section 900.

Strength

When lime is used for improving the sub grade, the soil-lime mix shall be tested for its CBR value. When lime stabilized soil is used in a sub-base, it shall be tested for unconfined compressive strength (UCS) at 7 days. In case of variation from the design CBR/UCS, in situ value being lower, the pavement design shall be reviewed based on the actual CBR/UCS values. The extra pavement thickness needed on account of lower CBR/UCS value shall be constructed by the Contractor at his own cost.

Arrangements for Traffic

During the period of construction, arrangements for traffic shall be provided and maintained in accordance with Clause 112.

Measurements for Payment

Stabilised soil sub-graded sub-base shall be measured as finished work in position in cubic metres.

Rate

The Contract unit rate for lime stabilized soil sub-graded/ sub-base shall be payment in full for carrying out the required operations including full compensation for all components listed in Clause 401.7 (i) to (v).

403 CEMENT TREATED SOIL AND CEMENT-FLYASH TREATED SUB-BASE/BASE

Scope

This work shall consist of laying and compacting a sub-base/base course of soil treated with cement or cement-fly ash on prepared sub grade/sub-base, in accordance with the requirements of these

Specifications and in conformity with the lines, grades and cross-sections shown on the drawings or as directed by the Engineer.

Materials

Material to be Treated

The material used for cement or cement-flyash treatment shall be soil including sand and gravel, laterite, kankar, brick aggregate, crushed rock or slag or any combination of these. For use in a sub-base course, the material shall have a grading shown in Table 400-4. It shall have a uniformity coefficient not less than 5, capable of producing a well-closed surface finish. For use in a base course, the material shall be sufficiently well graded to ensure a well-closed surface finish and have a grading within the range given in Table 400-4. If the material passing 425 micron sieve is plastic, it shall have a liquid limit not greater than 45 percent and a plasticity index not greater than 20 percent determined in accordance with IS:2720 (Part 5). The physical requirements for the material to be treated with cement for use in a base course shall be same as for Grading I Granular Sub-base, Clause 401.2.2.

Cement

Cement for stabilization shall either be ordinary Portland Cement, Portland Slag Cement or Portland Pozzolana Cement and shall comply with the requirements of IS:269, 455 or 1489 respectively.

Table 400-4 : Grading Limits of Material for Stabilisation with Cement

IS sieve size	Percentage by mass passing Sub-Base/Base within the range
53.00 mm	100
37.5 mm	95 – 100
19.0 mm	45 – 100
9.5 mm	35 – 100
4.75 mm	25 – 100
600 micron	8 – 65
300 micron	5 – 40
75 micron	0 – 10

Lime

If needed for pre-treatment of highly clayey soils, Clause 402.2.2 shall apply.

Fly ash

Fly ash may be from anthracitic coal or lignitic coal. Fly ash to be used for cement-fly ash treatment shall conform to the requirement given in Tables 400-5 and 400-6.

Table 400-5 : Chemical Requirements for Fly Ash as Pozzolana

Sl. No.	Characteristics	Requirements for Fly Ash		Method of Test
		Anthracitic Flyash	Lignitic Flyash	
1)	SiO ₂ +Al ₂ O ₃ +Fe ₂ O ₃ in percent by mass,Min	70	50	IS:1727
2)	SiO ₂ in percent by mass, Min	35	25	IS:1727
3)	MgO in percent by mass, Max	25	5.0	IS:1727
4)	SO ₃ in percent by mass, Max	2.75	3.5	IS:1727
5)	Available alkalis as Na ₂ O/K ₂ O in percent by mass, Max,	1.5	1.5	IS:4032

6)	Total chlorides in percent by mass, Max	0.05	0.05	IS:1727
7)	Loss on ignition in percent by mass, Max	5.0	5.0	IS:1727

Table 400-6 : Physical Requirement for Fly Ash as a Pozzolona

Sl. No.	Characteristics	Requirement
1)	Fineness-specific surface in m ² /Kg by Blaine's permeability test, Min	250
2)	Particles retained on 45 micron IS sieve, Max	40
3)	Lime reactivity in N/mm ² , Min	3.5
4)	Soundness by autoclave test expansion of specimen in percent,Max	0.8
5)	Soundness by Lechatelier method-expansion in mm, Max	10

Pond ash or bottom ash, which do not meet the requirements of Tables 400-5 and 400-6 can also be used for cement-flyash treatment. However, in all cases of cement stabilized fly-ash/bottom ash/ pond ash, mix should develop adequate strength.

Quantity of Cement in Cement-Soil Stabilised Mix

The quantity of cement to be added as percent by weight of the dry soil shall be specified in the Contract. Also if lime is used as pretreatment for highly clayey soils, the quantity as percent by weight of dry soil shall be specified in the Contract. The mix design shall be done on the basis of 7 day unconfined compressive strength (UCS) and/or durability test under 12 cycles of wet-dry conditions. The laboratory strength values shall be at least 1.5 times the minimum field UCS value stipulated in the Contract.

Quantity of Cement in Cement/Fly Ash Treated Sub-base/Base

The quantity of cement shall be more than 2 percent by weight of cement/ fly-ash mix. The mix design shall be done to achieve a strength of 1.75 MPa when tested on cylindrical specimens compacted to the density at optimum moisture content, tested in accordance with IS:2720 (Part 8 as specified in the contract) after 7 days moist curing. The design mix shall indicate the proportions of cement and fly ash and the quantity of water to be mixed.

Water

The water to be used for cement stabilization shall be clean and free from injurious substances. Potable water shall be used.

Construction Operations

Weather Limitations

Stabilisation shall not be done when the air temperature in the shade is less than 10°C.

Degree of Pulverisation

For stabilisation, the soil before addition of cement shall be pulverised, where necessary, to the extent that it passes the requirements as set out in Table 400-7 when tested in accordance with the method described in Appendix-3.

Table 400-7 : Soil Pulverisation Requirements for Cement Stabilisation

IS sieve Designation	Minimum percent by weight passing the IS sieve
26.5 mm	100
5.6 mm	80

Clauses 402.3.3 to 402.3.5 shall apply as regards spreading and mixing the stabilizer except that cement or lime plus cement as the case may be, shall be used as the stabilizing material in place of lime.

Moisture Content for Compaction

The moisture content at compaction checked vide IS:2720 (Part 2) shall not be less than the optimum moisture content corresponding to IS:2720 (Part 8) nor more than 2 percent above it.

Rolling

Clause 402.3.8 shall apply except that care shall be taken to see that the compaction of cement stabilised material is completed within two hours of its mixing or such shorter period as may be found necessary in dry weather.

Curing

The sub-base/base course shall be suitably cured for 7 days. Subsequent pavement courses shall be laid soon after to prevent the surface from drying out and becoming friable. No traffic of any kind shall ply over the completed sub-base unless permitted by the Engineer.

Surface Finish

The surface finish of construction shall conform to the requirements of Clause 902.

Strength and Quality Control

Control on the quality of materials and works shall be exercised by the Engineer in accordance with Section 900.

Cement treated soil sub-base/base and cement/fly ash treated sub-base/base shall be tested for the unconfined compressive strength (UCS) value at 7 days, actually obtained in-situ. In case of variation from the design UCS, in-situ value being on lower side, prior to proceeding with laying of base/surface course on it, the pavement design shall be reviewed for actual UCS value. The extra pavement thickness needed on account of lower UCS shall be constructed by the Contractor at his own cost.

Arrangements for Traffic

During the period of construction, arrangements for traffic shall be provided and maintained in accordance with Clause 112.

Measurements for Payment

Stabilised soil sub-base/base shall be measured as finished work in position in cubic metres.

Rate

The Contract unit rate for cement treated soil sub-base/base with pretreatment with lime if required and cement/fly ash treated sub-base/base shall be payment in full for carrying out required operations including full compensation for all components listed in Clause 401.7 (i) to (v).

Scope

This work shall consist of clean crushed aggregates mechanically interlocked by rolling and bonding together with screening, binding material where necessary and water laid on a properly prepared subgrade/sub-base/base or existing pavement, as the case may be and finished in accordance with the requirements of these Specifications and in close conformity with the lines, grades, cross-sections and thickness as per approved plans or as directed by the Engineer.

Materials

Coarse Aggregates

Coarse aggregates shall be either crushed or broken stone, crushed slag, overburnt (Jhama) brick aggregates or any other naturally occurring aggregates such as kankar and laterite of suitable quality. Materials other than crushed or broken stone and crushed slag shall be used in sub-base courses only. If crushed gravel /shingle is used, not less than 90 percent by weight of the gravel/shingle pieces retained on 4.75 mm sieve shall have at least two fractured faces. The aggregates shall conform to the physical requirements set forth in **Table 400-8**. The type and size range of the aggregate shall be specified in the Contract or shall be as specified by the Engineer. If the water absorption value of the coarse aggregate is greater than 2 percent, the soundness test shall be carried out on the material delivered to site as per IS:2386 (Part 5).

**Table 400-8 : Physical Requirements of Coarse Aggregates for Water Bound
Macadam for Sub-base/Base Courses**

S.No.	Test	Test Method	Requirements
1) ***	Los Angeles Abrasion value or Aggregate Impact value	IS: 2386(Part 4) IS: 2386 (Part-4) or IS:5640*	40 percent (Max) 30 percent (Max)
2)	Combined Flakiness and Elongation Indices (Total) **	IS:2386 (Part-1)	35 percent (Max)

* Aggregates which get softened in presence of water shall be tested for Impact value under wet conditions in accordance with IS:5640.

** The requirement of flakiness index and elongation index shall be enforced only in the case of crushed broken stone and crushed slag.

*** In case water bound macadam is used for sub-base, the requirements in respect of Los Angeles Value and Aggregate Impact Value shall be relaxed to 50 percent and 40 percent maximum respectively.

Crushed or Broken Stone

The crushed or broken stone shall be hard, durable and free from excess flat, elongated, soft and disintegrated particles, dirt and other deleterious material.

Crushed Slag

Crushed slag shall be made from air-cooled blast furnace slag. It shall be of angular shape, reasonably uniform in quality and density and generally free from thin, elongated and soft pieces, dirt or other deleterious materials. The weight of crushed slag shall not be less than kN per m³ and the percentage of glossy material shall not be more than 20. It should also comply with the following requirements:

- i) Chemical stability : To comply with requirements of appendix of BS:1047
- ii) Sulphur content : Maximum 2 percent
- iii) Water absorption : Maximum 10 percent

Overburnt (Jhama) Brick Aggregates

Jhama brick aggregates shall be made from over burnt bricks or brick bats and be free from dust and other objectionable and deleterious materials. This shall be used only for road stretch when traffic is low.

Grading Requirement of Coarse Aggregates

The coarse aggregates shall conform to one of the Grading given in Table 400-9 as specified.

Screenings

Screenings to fill voids in the coarse aggregate shall generally consist of the same material as the coarse aggregate. However, where permitted, predominantly non-plastic material such as moorum or gravel (other than rounded river borne material) may be used for this purpose provided liquid limit and plasticity index of such material are below 20 and 6 respectively and fraction passing 75 micron sieve does not exceed 10 percent.

Table 400-9 : Grading Requirements of Coarse Aggregates

Grading No.	Size Range	IS Sieve Designation	Percent by weight Passing
1)	63 mm to 45 mm	75 mm	100
		63 mm	90 – 100
		53 mm	25 – 75
		45 mm	0 – 15
		22.4 mm	0 – 5
2)	53 mm to 22.4 mm	63 mm	100
		53 mm	95 – 100
		45 mm	65 – 90
		22.4 mm	0 – 10
		11.2 mm	0 – 5

Note : The compacted thickness for a layer shall be 75 mm.

Screenings shall conform to the grading set forth in Table 400-10. The quantity of screenings required for various grades of stone aggregates are given in Table 400-11. The Table also gives the quantities of materials (loose) required for 10 m² for sub-base/base compacted thickness of 75 mm.

The use of screenings shall be omitted in the case of soft aggregates such as brick metal, kankar, laterites, etc. as they are likely to get crushed to a certain extent under rollers.

Binding Material

Binding material to be used for water bound macadam as a filler material meant for preventing graveling shall comprise of a suitable material approved by the Engineer having a Plasticity Index (PI) value of less than 6 as determined in accordance with IS:2720 (Part-5).

The quantity of binding material where it is to be used, will depend on the type of screenings. Generally, the quantity required for 75 mm compacted thickness of water bound macadam will be 0.06–0.09 m³ per 10 m².

Table 400-10 : Grading For Screenings

Grading Classification	Size of Screenings	IS Sieve Designation	Percent by Weight Passing the Sieve
A	13.2 mm	13.2 mm	100
		11.2 mm	95 – 100
		5.6 mm	15 - 35
		180 micron	0 – 10
B	11.2 mm	11.2 mm	100
		9.5 mm	80 – 100
		5.6 mm	50 – 70
		180 micron	5 – 25

**Table 400-11 : Approximate Quantities of Coarse Aggregates and Screenings
Required for 75 mm Compacted Thickness of Water Bound Macadam (WBM)Sub-
Base/Base Course for 10 m² Area**

Classification	Size Range	Compacted Thickness	Loose Qty.	Screenings			
				Stone Screening		Crushable Type Such as Moorum or Gravel	
				Grading Classification & Size	For WBM Sub-base/ Base Course (Loose Quantity)	Grading Classification & Size	Loose Qty.
Grading 1	63 mm to 45 mm	75 mm	0.91 to 1.07 m ³	Type A 13.2 mm	0.12 to 0.15 m ³	Not uniform	0.22 to 0.24 m ³
-do-	-do-	-do-	-do-	Type B 11.2 mm	0.20 to 0.22 m ³	-do-	-do-
Grading 2	53 mm to 22.4 mm	75 mm	-do-	-do-	0.18 to 0.21 m ³	-do-	-do-

The above mentioned quantities should be taken as a guide only, for estimation of quantities for construction etc.

Application of binding materials may not be necessary when the screenings used are of crushable type such as moorum or gravel.

Construction Operations

Preparation of Base

The surface of the sub-grade/sub-base/base to receive the water bound macadam course shall be prepared to the specified grade and camber and cleaned of dust, dirt and other extraneous material. Any ruts or soft yielding places shall be corrected in an approved manner and rolled until firm surface is obtained.

Where the WBM is to be laid on an existing metalled road, damaged area including depressions and potholes shall be repaired and made good with the suitable material. The existing surface shall be scarified and re-shaped to the required grade and camber before spreading the coarse aggregate for WBM.

As far as possible, laying water bound macadam course over existing bituminous layer may be avoided since it will cause problems of internal drainage of the pavement at the interface of two courses. It is desirable to completely pick out the existing thin bituminous wearing course where water bound macadam is proposed to be laid over it.

Inverted Choke/Sub-surface Drainage Layer

If water bound macadam is to be laid directly over the sub-grade, without any other intervening pavement course, a 25 mm course of screenings (Grading B) or coarse sand shall be spread on the prepared sub-grade before application of the aggregates is taken up. In case of a finesand or silty or clayey sub-grade, it is advisable to lay 100 mm insulating layer of screening or coarse sand on top of fine grained soil, the gradation of which will depend upon whether it is intended to act as a drainage layer as well. As a preferred alternative to inverted choke, appropriate geosynthetics performing functions of separation and drainage may be used over the prepared sub-grade as directed by the Engineer. Section 700 shall be applicable for use of geosynthetics.

Lateral Confinement of Aggregates

For construction of WBM, arrangement shall be made for the lateral confinement of aggregates. This shall be done by building adjoining shoulders along with WBM layers. The practice of constructing WBM in a trench section excavated in the finished formation must be completely avoided.

Where the WBM course is to be constructed in narrow widths for widening of an existing pavement, the existing shoulders should be excavated to their full depth and width up to the sub-grade level except where widening specifications envisage laying of a stabilised sub-base using in-situ operations in which case the same should be removed only up to the sub-base level

Spreading Coarse Aggregates

The coarse aggregates shall be spread uniformly and evenly upon the prepared sub-grade/sub-base in the required quantities from the stockpiles to proper profile by using templates placed across the road about 6 m apart, in such quantities that the thickness of each compacted layer is not more than 75 mm. In no case shall these be dumped in heaps directly on the area where these are to be laid nor shall their hauling over a partly completed base be permitted. Wherever possible, approved mechanical devices such as aggregate spreaders shall be used to spread the aggregates uniformly so as to minimize the need for manual rectification afterwards.

No segregation of coarse aggregates shall be allowed and the coarse aggregates, as spread shall be of uniform gradation with no pockets of fine material.

The surface of the aggregates spread shall be carefully checked with templates and all high or low spots remedied by removing or adding aggregates as may be required. The surface shall be checked frequently with a straight edge while spreading and rolling so as to ensure a finished surface as per approved drawings.

The coarse aggregates shall not normally be spread more than 3 days in advance of the subsequent construction operations.

Rolling

Immediately following the spreading of the coarse aggregates, rolling shall be started with three wheeled power rollers of 80 to 100 kN capacity or tandem or vibratory rollers of 80 to 100 kN static weight. The type of roller to be used shall be approved by the Engineer based on trial run.

Except on superelevated portions and carriageway with unidirectional cross-fall, where the rolling shall proceed from inner edge to the outer, rolling shall begin from the edges gradually progressing towards the center. First the edge/edges shall be compacted with roller running forward and backward. The roller shall then move inward parallel to the center line of the road, in successive passes uniformly overlapping preceding tracks by at least one-half width.

Rolling shall be carried out on courses where coarse aggregates of crushed/ broken stone are used, till the road metal is partially compacted. This will be followed by application of screenings and binding material where required in Clauses 404.3.6 and 404.3.7.

However, where screenings are not to be applied as in the case of aggregates like brick metal, laterite and Kankar for sub-base construction, the compaction shall be continued until the aggregates are thoroughly keyed. Rolling shall be continued and light sprinkling of water shall be done till the surface is well compacted.. Rolling shall not be done when the sub-

grade is soft or yielding or when it causes a wave-like motion in the sub-grade or sub-base course.

The rolled surface shall be checked transversely with templates and longitudinally with 3 m straight edge. Any irregularities, exceeding 12 mm, shall be corrected by loosening the surface, adding or removing necessary amount of aggregates and re-rolling until the entire surface conforms to the desired camber and grade. In no case shall the use of screenings be permitted to make up depressions.

Material, which gets crushed excessively during compaction or becomes segregated, shall be removed and replaced with suitable aggregates.

Application of Screenings

After the coarse aggregates have been rolled to Clause 404.3.5, screenings to completely fill the interstices shall be applied gradually over the surface. These shall not be damp or wet at the time of application. Dry rolling shall be done while the screenings are being spread so that vibrations of the roller cause them to settle into the voids of the coarse aggregates. The screenings shall not be dumped in piles but be spread uniformly in successive thin layers either by the spreading motions of hand shovels or by mechanical spreaders, or directly from tipper with suitable grit spreading arrangement. Tipper operating for spreading the screenings shall be equipped with pneumatic tyres and operated so as not to disturb the coarse aggregates.

The screenings shall be applied at a slow and uniform rate (in three or more applications) so as to ensure filling of all voids. This shall be accompanied by dry rolling and brooming with mechanical brooms, hand brooms or both. In no case shall the screenings be applied so fast and thick as to form cakes or ridges on the surface in such a manner as would prevent filling of voids or prevent the direct bearing of the roller on the coarse aggregates. These operations shall continue until no more screenings can be forced into voids of the coarse aggregates. The spreading, rolling, and brooming of screenings shall be carried out in only such lengths of the road which could be completed within one day's operation.

Sprinkling of Water and Grouting

After application of screenings, the surface shall be copiously sprinkled with water, swept and rolled. Hand brooms shall be used to sweep the wet screenings into voids and to distribute them evenly. The sprinkling, sweeping and rolling operation shall be continued, with additional screenings applied as necessary until the coarse aggregates have been thoroughly keyed, well-bonded and firmly set in its full depth and a grout has been formed of screenings. Care shall be taken to see that the sub-base or sub-grade does not get damaged due to the addition of excessive quantities of water during construction.

In case of lime treated soil sub-base, construction of water bound macadam on top of it shall be taken up after curing as per Clause 402.3.9 and as directed by the Engineer.

Application of binding material : After the application of screenings in accordance with Clauses 404.3.6 and 404.3.7, the binding material where it is required to be used (Clause 404.2.7) shall be applied successively in two or more thin layers at a slow and uniform rate. After each application, the surface shall be copiously sprinkled with water, the resulting slurry swept in with hand brooms, or mechanical brooms to fill the voids properly, and rolled during which water shall be applied to the wheels of the rollers if necessary to wash down the binding material sticking to them.

These operations shall continue until the resulting slurry after filling of voids, forms a wave ahead of the wheels of the moving roller.

Setting and Drying

After the final compaction of water bound macadam course, the pavement shall be allowed to dry overnight. Next morning hungry spots shall be filled with screenings or binding material as directed, lightly sprinkled with water if necessary and rolled. No traffic shall be allowed on the road until the macadam has set. The Engineer shall have the discretion to stop hauling traffic from using the completed water bound macadam course, if in his opinion it would cause excessive damage to the surface.

The compacted water bound macadam course shall be allowed to completely dry and set before the next pavement course is laid over it.

Surface Finish and Quality Control of Work

The surface finish of construction shall conform to the requirements of Clause 902.

Control on the quality of materials and works shall be exercised by the Engineer in accordance with Section 900.

The water bound macadam work shall not be carried out when the atmosphere temperature is less than 10°C in the shade.

Reconstruction of Defective Macadam

The finished surface of water bound macadam shall conform to the tolerances of surface regularity as prescribed in Clause 902. However, where the surface irregularity of the course exceeds the tolerances or where the course is otherwise defective due to sub-grade soil mixing with the aggregates, the course to its full thickness shall be scarified over the affected area, reshaped with added material or removed and replaced with fresh material as applicable and re-compacted. The area treated shall not be less than 10 sq.m. In no case shall depressions be filled up with screenings or binding material.

Arrangements for Traffic

During the period of construction, the arrangements for traffic shall be done as per Clause 112.

Measurements for Payment

Water bound macadam shall be measured as finished work in position in cubic meters.

Rate

The Contract unit rate for water bound macadam sub-base/base course shall be payable in full for carrying out the required operations including full compensation for all components listed in Clause 401.7 (i) to (v), including arrangement of water used in the work as approved by the Engineer.

405 CRUSHED CEMENT CONCRETE SUB-BASE

Scope

This work shall consist of breaking and crushing the damaged cement concrete slabs and re-compacting the same as sub-base/base course in one or more layers. The work shall be performed on such widths and lengths as may be specified, in accordance with the requirements of these Specifications and in conformity with the lines, grades and cross-sections shown on the drawings or as otherwise directed by the Engineer.

Materials

Coarse Aggregates

Coarse aggregates for this work shall be broken cement concrete slabs crushed to a size not exceeding 75 mm and as far as possible, conforming to one of the gradings given in **Table 400-9**.

Construction Operations

General

Crushed cement concrete sub-base course may be constructed in one or two layers, depending upon the thickness of the concrete slabs dismantled and crushed. The thickness of each layer shall not exceed 75 mm compacted thickness.

Preparation of Surface

The surface of the subgrade shall be prepared in accordance with Clause 404.3.1.

Spreading of Aggregates

The sub-base material of grading specified in the Contract shall be spread on the prepared subgrade with the help of a motor grader of adequate capacity, its blade having hydraulic controls suitable for initial adjustment and for maintaining the required slope and grade during the operation, or other means as approved by the Engineer.

Rolling

Immediately following the spreading of the coarse aggregates, rolling shall be started with three wheeled power rollers of 80 to 100 kN capacity or tandem or vibratory rollers of 80 to 100 kN static weight. The type of roller to be used shall be approved by the Engineer based on trial run.

Except on superelevated portions and carriageway with unidirectional cross-fall where the rolling shall proceed from inner edge to the outer, rolling shall begin from the edges gradually progressing towards the center. First the edge/edges shall be compacted with roller running forward and backward. The roller shall then move inward parallel to the center line of the road, in successive passes uniformly overlapping preceding tracks by at least one-half width.

Rolling shall be continued and light sprinkling of water shall be done till the surface is well compacted.

The rolled surface shall be checked transversely with templates and longitudinally with 3 m straight edge. Any irregularities, exceeding 12 mm, shall be corrected by loosening the surface, adding or removing necessary amount of aggregates and re-rolling until the entire surface conforms to the desired camber and grade.

Surface Finish and Quality Control of Work

The surface finish and control on the quality of materials and works shall be exercised by the Engineer in accordance with Section 900.

Arrangements for Traffic

During the period of construction, arrangement for traffic shall be done as per Clause 112.

Measurements for Payment

Breaking the existing cement concrete pavement slabs, crushing and recompacting the slab material as sub-base course shall be measured as a single item in terms of the volume of sub-base laid in position in cubic metres.

Rate

The Contract unit rate for crushed cement concrete sub-base course shall be payment in full for carrying out the required operations including full compensation for:

- i) making arrangements for traffic to Clause 112 except for initial treatment to verges/shoulders and construction of diversions;
- ii) breaking the cement concrete slabs, crushing, sieving and recompacting the slab material as sub-base course;
- iii) all labour, tools, equipment and incidentals to complete the work to the Specifications;
- iv) carrying out the work in part widths of road where directed; and
- v) carrying out the required tests for quality control.

406 WET MIX MACADAM SUB-BASE/BASE

Scope

This work shall consist of laying and compacting clean, crushed, graded aggregate and granular material, premixed with water, to a dense mass on a prepared sub-grade/sub-base/base or existing pavement as the case may be in accordance with the requirements of these Specifications. The material shall be laid in one or more layers as necessary to lines, grades and cross-sections shown on the approved drawings or as directed by the Engineer.

The thickness of a single compacted Wet Mix Macadam layer shall not be less than 75 mm. When vibrating or other approved types of compacting equipment are used, the compacted depth of a single layer of the sub-base course may be up to 200 mm with the approval of the Engineer.

Materials

Aggregates

Physical Requirements

Coarse aggregates shall be crushed stone. If crushed gravel/shingle is used, not less than

90 percent by weight of the gravel/shingle pieces retained on 4.75 mm sieve shall have at least two fractured faces. The aggregates shall conform to the physical requirements set forth in Table 400-12.

If the water absorption value of the coarse aggregate is greater than 2 percent, the soundness test shall be carried out on the material delivered to site as per IS:2386 (Part-5).

Table 400-12 : Physical Requirements of Coarse Aggregates for Wet Mix Macadam for Sub-base/Base Courses

S. No.	Test	Test Method	Requirements
1)	Los Angeles Abrasion value or Aggregate Impact value	IS:2386 (Part-4) IS:2386 (Part-4) or IS:5640	40 percent (Max.) 30 percent (Max.)
2)	Combined Flakiness and Elongation indices (Total)	IS:2386 (Part-1)	35 percent (Max.)*

* To determine this combined proportion, the flaky stone from a representative sample should first be separated out. Flakiness index is weight of flaky stone metal divided by weight of stone sample. Only the elongated particles be separated out from the remaining (non-flaky) stone metal. Elongation index is weight of elongated particles divided by total non-flaky particles. The values of flakiness index and elongation index so found are added up.

Grading Requirements

The aggregates shall conform to the grading given in Table 400-13.

Table 400-13 : Grading Requirements of Aggregates for Wet Mix Macadam

IS Sieve Designation	Percent by weight passing the IS Sieve
53.00 mm	100
45.00 mm	95–100
26.50 mm	–
22.40 mm	60–80
11.20 mm	40–60
4.75 mm	25–40
2.36 mm	15–30
600.00 micron	8–22
75.00 micron	0–5

Material finer than 425 micron shall have Plasticity Index (PI) not exceeding 6.

The final gradation approved within these limits shall be graded from coarse to fine and shall not vary from the low limit on one sieve to the high limit on the adjacent sieve or vice versa.

Construction Operations

Preparation of Base

Clause 404.3.1 shall apply.

Provision of Lateral Confinement of Aggregates

While constructing wet mix macadam, arrangement shall be made for the lateral confinement of wet mix. This shall be done by laying materials in adjoining shoulders along with that of wet mix macadam layer and following the sequence of operations described in Clause 404.3.3.

Preparation of Mix

Wet Mix Macadam shall be prepared in an approved mixing plant of suitable capacity having provision for controlled addition of water and forced/ positive mixing arrangement like pug mill or pan type mixer of concrete batching plant. The plant shall have following features:

- i) For feeding aggregates– three/ four bin feeders with variable speed

motor

- ii) Vibrating screen for removal of oversize aggregates
- iii) Conveyor Belt
- iv) Controlled system for addition of water
- v) Forced/positive mixing arrangement like pug-mill or pan type mixer
- vi) Centralized control panel for sequential operation of various devices and precise process control
- vii) Safety devices

Optimum moisture for mixing shall be determined in accordance with IS:2720 (Part-8) after replacing the aggregate fraction retained on 22.4 mm sieve with material of 4.75 mm to 22.4 mm size. While adding water, due allowance should be made for evaporation losses. However, at the time of compaction, water in the wet mix should not vary from the optimum value by more than agreed limits. The mixed material should be uniformly wet and no segregation should be permitted.

Spreading of Mix

Immediately after mixing, the aggregates shall be spread uniformly and evenly upon the prepared sub-grade/sub-base/base in required quantities. In no case shall these be dumped in heaps directly on the area where these are to be laid nor shall their hauling over a partly completed stretch be permitted.

The mix may be spread by a paver finisher. The paver finisher shall be self-propelled of adequate capacity with following features:

- i) Loading hoppers and suitable distribution system, so as to provide a smooth uninterrupted material flow for different layer thicknesses from the tipper to the screed.
- ii) Hydraulically operated telescopic screed for paving width upto to 8.5 m and fixed screed beyond this. The screed shall have tamping and vibrating arrangement for initial compaction of the layer.
- iii) Automatic levelling control system with electronic sensing device to maintain mat thickness and cross slope of mat during laying procedure.

In exceptional cases where it is not possible for the paver to be utilized, mechanical means like motor grader may be used with the prior approval of the Engineer. The motor grader shall be capable of spreading the material uniformly all over the surface.

The surface of the aggregate shall be carefully checked with templates and all high or low spots remedied by removing or adding aggregate as may be required. The layer may be tested by depth blocks during construction. No segregation of larger and fine particles should be allowed. The aggregates as spread should be of uniform gradation with no pockets of fine materials.

The Engineer may permit manual mixing and /or laying of wet mix macadam where small quantity of wet mix macadam is to be executed. Manual mixing/laying in inaccessible/ remote locations and in situations where use of machinery is not feasible can also be permitted. Where manual mixing/laying is intended to be used, the same shall be done with the approval of the Engineer.

Compaction

After the mix has been laid to the required thickness, grade and cross fall/camber the same shall be uniformly compacted to the full depth with suitable roller. If the thickness of single compacted layer does not exceed 100 mm, a smooth wheel roller of 80 to 100kN weight may be used. For a compacted single layer upto 200 mm, the compaction shall be done with the help of vibratory roller of minimum static weight of 80 to 100 KN with an arrangement

for adjusting the frequency and amplitude. An appropriate frequency and amplitude may be selected. The speed of the roller shall not exceed 5 km/h.

In portions having unidirectional cross fall/super elevation, rolling shall commence from the lower edge and progress gradually towards the upper edge. Thereafter, roller should progress parallel to the center line of the road, uniformly over-lapping each preceding track by at least one-third width until the entire surface has been rolled. Alternate trips of the roller shall be terminated in stops at least 1 m away from any preceding stop.

In portions in camber, rolling should begin at the edge with the roller running forward and backward until the edges have been firmly compacted. The roller shall then progress gradually towards the center parallel to the center line of the road uniformly overlapping each of the preceding track by at least one-third width until the entire surface has been rolled.

Any displacement occurring as a result of reversing of the direction of a roller or from any other cause shall be corrected at once as specified and/or removed and made good.

Along forms, kerbs, walls or other places not accessible to the roller, the mixture shall be thoroughly compacted with mechanical tampers or a plate compactor. Skin patching of an area without scarifying the surface to permit proper bonding of the added material shall not be permitted.

Rolling should not be done when the sub-grade is soft or yielding or when it causes a wave-like motion in the sub-base/base course or sub-grade. If irregularities develop during rolling which exceed 12 mm when tested with a 3 m straight edge, the surface should be loosened and premixed material added or removed as required before rolling again so as to achieve a uniform surface conforming to the desired grade and crossfall. In no case shall the use of unmixed material be permitted to make up the depressions.

Rolling shall be continued till the density achieved is at least 98 percent of the maximum dry density for the material as determined by the method outlined in IS:2720 (Part-8).

After completion, the surface of any finished layer shall be well-closed, free from movement under compaction equipment or any compaction planes, ridges, cracks and loose material. All loose, segregated or otherwise defective areas shall be made good to the full thickness of the layer and recompact.

Setting and Drying

After final compaction of wet mix macadam course, the road shall be allowed to dry for 24 hours.

Opening to Traffic

No vehicular traffic shall be allowed on the finished wet mix macadam surface. Construction equipment may be allowed with the approval of the Engineer.

Surface Finish and Quality Control of Work

Surface Evenness

The surface finish of construction shall conform to the requirements of Clause 902.

Quality Control

Control on the quality of materials and works shall be exercised by the Engineer in accordance with Section 900.

Rectification of Surface Irregularity

Where the surface irregularity of the wet mix macadam course exceeds the permissible tolerances or where the course is otherwise defective due to sub-grade soil getting mixed with the aggregates, the full thickness of the layer shall be scarified over the affected area, re-shaped with added premixed material or removed and replaced with fresh premixed material as applicable and recompact in accordance with Clause 406.3. The area treated in the aforesaid manner shall not be less than 5 m long and 2 m wide. In no case shall depressions be filled up with unmixed and ungraded material or fines.

Arrangement for Traffic

During the period of construction, arrangements for traffic shall be done as per Clause 112.

Measurements for Payment

Wet mix macadam shall be measured as finished work in position in cubic metres.

Rate

The Contract unit rate for wet mix macadam shall be payment in full for carrying out the required operations including full compensation for all components listed in Clause 401.7.

407 CRUSHER-RUN MACADAM BASE

Scope

This work shall consist of furnishing, placing and compacting crushed stone aggregate

sub-base and base courses constructed in accordance with the requirements set forth in these Specifications and in conformity with the lines, grades, thickness and cross-sections shown on the drawings or as directed by the Engineer.

Materials

The material to be used for the work shall be crushed rock. If crushed gravel/shingle is used, not less than 90 percent by weight of the gravel/shingle pieces retained on 4.75 mm sieve shall have at least two fractured faces. It shall be free from any organic matter and other deleterious substances and shall be of such nature that it can be compacted readily under watering and rolling to form a firm, stable base. The aggregates shall conform to the grading and quality requirements given in Tables 400-14 and 400-15.

The grading to be adopted shall be as indicated in the Contract.

Construction Operations Preparation of Sub-grade

The surface of the sub-grade shall be prepared in accordance with Clause 404.3.1. Any ruts, deformations or soft yielding places which occur in the sub-base or sub-grade shall be corrected and compacted to the required density before the aggregate base course is placed thereon.

Spreading, Watering, Mixing and Compaction

The aggregate shall be uniformly deposited on the approved subgrade by means of hauling vehicle with or without spreading devices. Aggregate will be distributed over the surface to the depth specified on the drawings or as directed by the Engineer.

Table 400-14 : Aggregate Grading Requirements

Sieve Size	Percent passing by weight	
	53 mm max. size	37.5 mm max. size
63 mm	100	
45 mm	87 – 100	100
22.4 mm	50 – 85	90 – 100
5.6 mm	25 – 45	35 – 55
710 mm	10 – 25	10 – 30
90 mm	2 – 5	2 – 5

Table 400-15 : Physical Requirements of Coarse Aggregates for Crusher-Run Macadam Base

	Test	Test Method	Requirements
1)	Los Angeles Abrasion value or Aggregate Impact value	IS:2386 (Part 4) IS:2386 (Part 4) or IS:5640	40 maximum 30 maximum
2)	Combined Flakiness and Elongation Indices (Total)	IS:2386 (Part 1)	35 maximum**
3)	*Water absorption	IS:2386 (Part 3)	2 percent maximum
4)	Liquid Limit of material passing 425 micron	IS:2720 (Part 5)	25 maximum
5)	Plasticity Index of material passing 425 micron	IS:2720 (Part 5)	6 maximum

* If the water absorption is more than 2 percent, soundness test shall be carried out as per IS:2386 (Part-5)

** To determine this combined proportion, the flaky stone from a representative sample should first be separated out. Flakiness index is weight of flaky stone metal divided by weight of stone sample. Only the elongated particles be separated out from the remaining (non-flaky) stone metal. Elongation index is weight of elongated particles divided by total non-flaky particles. The value of flakiness index and elongation index so found are added up.

After the base course material has been deposited, it shall be thoroughly blade-mixed to full depth of the layer by alternately blading the entire layer to the center and back to the edges of the road. It shall then be spread and finished to the required cross-section by means of a motor grader.

Water shall be applied prior to and during all blading and processing operations to moisten the material sufficiently to prevent segregation of the fine and coarse particles. Water shall be applied in sufficient amounts during construction to assist in compaction.

Compaction shall commence immediately after the spreading operation. If the thickness of single compacted layer does not exceed 100 mm, a smooth wheel roller of 80 to 100 kN weight may be used. For a compacted single layer up to 200 mm, compaction shall be done with the help of vibratory roller of minimum static weight of 80 to 100 kN or equivalent capacity. The speed of the roller shall not exceed 5 km/h. Each layer of material shall be compacted to not less than 98 percent of the maximum density as determined by IS:2720 (Part-8).

Opening to Traffic

No vehicular traffic shall be allowed on the finished crusher-run macadam surface. Construction equipment may be allowed with the approval of the Engineer.

Surface Finish and Quality Control of Work

The surface finish of construction shall conform to the requirements of Clause 902.

Control on the quality of materials and work shall be exercised by the Engineer in accordance with Section 900.

Arrangements for Traffic

During the period of construction, arrangements for traffic shall be done in accordance with Clause 112.

Measurements for Payment

Crusher-run macadam base shall be measured as finished work in position in cubic metres.

Rate

The Contract unit rate for crusher run macadam base shall be payment in full for carrying out the required operations including full compensation for all components as in Clause 401.7 (i) to (v).

408 SHOULDERS, ISLANDS AND MEDIANS

Scope

The work shall consist of constructing shoulder (hard/paved/earthen with brick or stone block edging) on either side of the pavement, median in the road dividing the carriageway into separate lanes and islands for channelising the traffic at junctions in accordance with the requirements of these Specifications and in conformity with the lines, grades and cross-sections shown on the drawings or as directed by the Engineer.

Materials

Shoulder on either side of the road may be of selected earth/granular material/paved conforming to the requirements of Clause 305/401 and the median may be of selected earth conforming to the requirements of Clause 305.

Median/Traffic islands shall be raised and kerbed at the perimeter and the enclosed area filled with earth and suitably covered with grass turf/shrubs as per Clause 307 and/or paved as per Clauses 410.3.4 or 410.3.5.

Paved shoulders shall consist of sub-base, base and surfacing courses, as shown in the drawings and materials for the same shall conform to relevant Specifications of the corresponding items. Where paved or hard shoulders are not provided, the pavement shall be provided with brick/stone block edgings as shown in the drawings. The brick shall conform to Clause 1003 of these Specifications. Stone blocks shall conform to Clause 1004 of these Specifications and shall be of size 225 mm x 110 mm x 75 mm.

Size of Shoulders/Medians/Islands

Shoulder (earthen/hard/paved)/median/traffic island dimensions shall be as shown on the drawings or as directed by the Engineer.

Construction Operations

Shoulders

The sequence of operations shall be such that the construction of paved shoulder is done in layers each matching the thickness of adjoining pavement layer. Only after a layer of pavement and corresponding layers in paved and earth shoulder portion have been laid and compacted, the construction of next layer of pavement and shoulder shall be taken up.

Where the materials in adjacent layers are different, these shall be laid together and the pavement layer shall be compacted first. The corresponding layer in paved shoulder portion shall be compacted thereafter, which shall be followed by compaction of each shoulder layer. The adjacent layers having same material shall be laid and compacted together.

In all cases where paved shoulders have to be provided along side of existing carriageway, the existing shoulders shall be excavated in full width and to the required depth as per Clause 301.3.7. Under no circumstances, box cutting shall be done for construction of shoulders.

Compaction requirement of earthen shoulder shall be as per Table 300-3. In the case of bituminous courses and concrete pavement, work on shoulder shall start only after the pavement course has been laid and compacted.

During all stages of shoulder construction, the required crossfall shall be maintained to drain off surface water.

Regardless of the method of laying, all shoulder construction material shall be placed directly

on the shoulder. Any spilled material dragged on to the pavement surface shall be immediately removed, without damage to the pavement, and the area so affected thoroughly cleaned.

Median and Islands

Median and islands shall be constructed in a manner similar to shoulder up to the road level. Thereafter, the median and islands, if raised, shall be raised at least 300 mm by using kerb stones of approved material and dimensions and suitably finished and painted as directed by the Engineer. If not raised, the median and islands shall be differentiated from the shoulder/pavement as the case may be, as directed by the Engineer. The confined area of the median and islands shall be filled with local earth or granular material or any other approved material and compacted by plate compactor/power rammer. The confined area after filling with earth shall be turfed with grass or planted with shrubs, or finished with tiles/slabs as provided in the drawings.

Brick/Stone Block Edging

The brick/stone blocks shall be laid on edge, with the length parallel to the transverse direction of the road. They shall be laid on a bed of 25 mm sand, set carefully rolled into position by a light roller and made flush with the finished level of the pavement.

Surface Finish and Quality Control of Works

The surface finish of construction shall conform to the requirements of Clause 902. Control on the quality of materials and works shall be exercised by the Engineer in accordance with **Section 900**.

Measurements for Payment

Shoulder (earthen/hard/paved), island and median construction shall be measured as finished work in position as below:

- i) For excavation in cu.m.
- ii) For earthwork/granular fill in cu.m.
- iii) For sub-base, base, surfacing courses in units as for respective items
- iv) For kerb in running metre; length of kerb for median shall be measured for each side separately.
- v) For turfing, shrubs and tile/slab finish in sq.m.
- vi) For brick/stone block edging in running metre, the length for brick/ stone block edging for median edging shall be measured for each side separately.

Rate

The Contract unit rate for shoulder (hard/paved/earthen with brick or stone block edging), island and median construction shall be payment in full for carrying out the required operations including full compensation for all components listed in Clause 401.7 (i) to (v) as applicable. The rate for brick/stone block edging shall include the cost of sand cushion.

409 CEMENT CONCRETE KERB AND KERB WITH CHANNEL

Scope

This work shall consist of constructing cement concrete kerbs and kerbs with channel in the central median and/or along the footpaths or separators in conformity with the lines, levels and dimensions as specified in the drawings or as directed by the Engineer.

Materials

Kerbs and kerb with channel shall be provided in cement concrete of Grade M 20 in accordance with Section 1700 of these Specifications.

Type of Construction

These shall be cast-in-situ construction with suitable kerb casting machine in all situations except at locations where continuous casting with equipment is not practicable. In those locations precast concrete blocks shall be used.

Equipment

A continuous kerb casting equipment of adequate capacity and controls, capable of laying the kerbs in required cross-sections and producing a well-compacted mass of concrete free of voids and honeycombs, shall be used.

Construction Operations

Kerb shall be laid on firm foundation of minimum 150 mm thickness of cement concrete of M 15 grade cast in-situ or on extended width of pavement. The foundation shall have a projection of 50 mm beyond the kerb stone. Before laying the foundation of lean concrete, the base shall be leveled and slightly watered to make it damp.

In the median portions in the straight reaches, the kerb shall be cast in continuous lengths. In the portions where footpath is provided and/or the slope of the carriageway is towards median (as in case of superelevated portion), there shall be sufficient gap/recess left in the kerb to facilitate drainage openings.

After laying the kerbs and just prior to hardening of the concrete, saw cut grooves shall be provided at 5 m intervals up to finished road level or as specified by the Engineer.

Kerbs on the drainage ends such as along the footpath or the median in superelevated portions, shall be cast with monolithic concrete channels as indicated in drawings. The slope of the channel towards drainage pipes shall be ensured for efficient drainage of the road surface.

Vertical and horizontal tolerances with respect to true line and level shall be ± 6 mm.

Measurements for Payment

Cement concrete kerb/kerb with channel including foundation shall be measured in linear metre for the complete item of work.

Rate

The Contract unit rates for cement concrete kerb/kerb with channel including foundation for kerb shall be payment in full compensation for furnishing all materials, labour, tools, equipment for construction and other incidental cost necessary to complete the work.

410 FOOTPATHS AND SEPARATORS

Scope

The work shall consist of constructing footpaths and/or separators at locations as specified in the drawings or as directed by the Engineer.

The lines, levels and dimensions shall be as per the drawings. The scope of the work shall include provision of all drainage arrangements as shown in the drawings or as directed by the Engineer.

Materials

The footpaths and separators shall be constructed with any of the following types:

- a) Cast-in-situ cement concrete of Grade M 20 as per Section 1700 of the Specifications. The minimum size of the panels shall be as specified in the drawings.
- b) Precast cement concrete blocks and interlocking blocks/tiles of grade not less than M 30 as per Section 1700 of the Specifications. The thickness and size of the cement concrete blocks or interlocking blocks/tiles shall be as specified in the drawings.
- c) Natural stone slab cut and dressed from stone of good and sound quality, uniform in texture, free from defects and at least equal to a sample submitted by the Contractor and approved by the Engineer. The thickness and size of the natural stone slab shall be as specified in the drawings.

Construction Operations

Drainage pipes below the footpath originating from the kerbs shall be first laid in the required slope and connected to the drains/sumps/storm water drain/drainage chutes as per provisions of the drawings, or as specified.

Portion on back side of kerbs shall be filled and compacted with granular sub-base material as per Clause 401 of the Specifications in specified thickness.

The base for cast-in-situ cement concrete panels/ tiles/ nature stone slab shall be prepared and finished to the required lines, levels and dimensions as indicated in the drawings.

Over the prepared base, precast concrete interlocking blocks/tiles/natural stone slabs and/or cast-in-situ slab shall be set/laid as described in Clauses 410.3.4 and 410.3.5.

Tiles/Natural Stone Slabs

The blocks/tiles/slabs shall be set on a layer of average 12 mm thick cement-sand mortar (1:3) laid on prepared base in such a way that there is no rocking. The gaps between the blocks/tiles/slabs shall not be more than 12 mm and shall be filled with cement-sand mortar(1:3).

Cast-in-Situ Cement Concrete

The panels of specified size shall be cast on the prepared base in panels of specified size in a staggered manner. Construction joints shall be provided as per Section 1700 of the Specifications.

Precast Concrete Blocks and Interlocking Concrete Block Pavements

The precast concrete blocks and interlocking concrete block pavement shall be laid on a bedding of sand of thickness specified in the drawing. The grading of the sand layer shall be as in Table 400-16.

Table 400-16

IS Sieve Size	Percent Passing
9.52 mm	100
4.75 mm	95-100
2.36 mm	80-100
1.18 mm	50-95
600 micron	25-60
300 micron	10-30
150 micron	0-15
75 micron	0-10

The joints shall be filled with sand passing a 2.35 mm size with the grading as in Table 400-17.

Table 400-17

IS Sieve Size	Percent Passing
2.36 mm	100
1.18 mm	90–100
600 micron	60–90
300 micron	30–60
150 micron	15–30
75 micron	0–10

The bedding sand slightly moist, the moisture content being about 4 percent. The bedding sand shall be compacted by vibratory plate compactor.

The blocks shall be laid to the levels indicated on the drawings and to the pattern directed by the Engineer. The surface tolerance shall be ± 10 mm with respect to the design level. The blocks shall be embedded using a hammer.

Measurements for Payment

Footpaths and separators shall be measured in Sq.m between inside of kerbs. The edge restraint block and kerb shall be measured separately in linear meter. The items pertaining to drainage shall be measured separately.

Rate

Contract unit rates shall be inclusive of full compensation for all labour, materials, tools, equipment for footpaths including the base. Cost of providing pipes and arrangement for their discharge into appropriate drainage channels shall be incidental to the construction of footpaths.

600

CONCRETE PAVEMENT

601 DRY LEAN CEMENT CONCRETE SUB-BASE

Scope

The work shall consist of construction of (zero slump) dry lean concrete sub-base for cement concrete pavement in accordance with the requirements of these Specifications and in conformity with the lines, grades and cross-sections shown on the drawings or as directed by the Engineer. The work shall include furnishing of all plant and equipment, materials and labour and performing all operations, in connection with the work, as approved by the Engineer.

The design parameters of dry lean concrete sub-base, viz., width, thickness, grade of concrete, details of joints, if any, etc. shall be as stipulated in the drawings.

Materials

Sources of Materials

The Contractor shall indicate to the Engineer the source of all materials with relevant test data to be used in the dry lean concrete work sufficiently in advance and the approval of the Engineer for the same shall be obtained at least 45 days before the scheduled commencement of the work in trial length. If the Contractor later proposes to obtain the materials from a different source during the execution of main work, he shall notify the Engineer with relevant test data for his approval at least 45 days before such materials are to be used.

Cement

Any of the following types of cement may be used with prior approval of the Engineer:

S. No.	Type	Conforming to
i)	Ordinary Portland Cement 43 Grade	IS:8112
ii)	Portland Slag Cement	IS:455
iii)	Portland Pozzolana Cement	IS:1489-Part I

If the subgrade soil contains soluble sulphates in a concentration more than 0.5 percent, sulphate resistant cement conforming to IS:6909 shall be used.

Cement to be used may preferably be obtained in bulk form. It shall be stored in accordance with stipulations contained in Clause 1014 and shall be subjected to acceptance test prior to its immediate use.

Fly-ash

Fly-ash upto 20 percent by weight of cementitious material (cement+flyash) may be used along with 43/53 grade cement may be used to replace OPC cement grade 43 upto 30 percent by weight of cement. Fly-ash shall conform to IS:3812 (Part 1) and its use shall be permitted only after ensuring that facilities exist for uniform blending through a proper mechanical facility with automated process control like batch mix plant conforming to IS:4925 and IS:4926.

Aggregates

Aggregates for lean concrete shall be natural material complying with IS:383. The aggregates shall not be alkali reactive. The limits of deleterious materials shall not exceed the requirements set forth in Table 600-2. In case the Engineer considers that the aggregates are not free from dirt, the same may be washed and drained for at least 72 hours before batching, or as directed by the Engineer.

Coarse Aggregates

Coarse aggregates shall comply with Clause 602.2.6.2, except that the maximum size of the coarse aggregate shall be 26.5 mm, and aggregate gradation shall comply with Table 600-1.

Fine Aggregates

The fine aggregate shall comply with Clause 602.2.6.3.

The material after blending shall conform to the grading as indicated in Table 600-1.

Table 600-1 : Aggregate Gradation for Dry Lean Concrete

Sieve Designation	Percentage by Weight Passing the Sieve
26.50 mm	100
19.0 mm	75-95
9.50 mm	50-70
4.75 mm	30-55
2.36 mm	17-42
600 micron	8-22
300 micron	7-17
150 micron	2-12
75 micron	0-10

Water

Water used for mixing and curing of concrete shall comply with Clause 602.2.7.

Storage of Materials

All materials shall be stored in accordance with the provisions of Clauses 602.2.12 of these Specifications and other relevant IS Specifications.

Proportioning of Materials for the Mix

The mix shall be proportioned with a maximum aggregate cementitious material ratio of 15:1. The water content shall be adjusted to the optimum as per Clause 601.3.2 for facilitating compaction by rolling. The strength and density requirements of concrete shall be determined in accordance with Clauses 601.7 and 601.8 by making trial mixes. Care should be taken to prevent one size of aggregate falling into the other size of the hopper of the feeding bin while loading the individual size of aggregates into the bins.

Moisture Content

The optimum water content shall be determined and demonstrated by rolling during trial length construction and the optimum moisture content and degree of compaction shall be got approved from Engineer. While laying in the main work, the lean concrete shall have a moisture content between the optimum and optimum +2 percent, keeping in view the effectiveness of compaction achieved and to compensate for evaporation losses.

Cement Content

The cement content in the dry lean concrete shall be such that the strength specified in Clause 601.3.4 is achieved. The minimum cement content shall be 150 kg/cu.m of concrete. In case flyash is blended at site as part replacement of cement, the quantity of flyash shall not be more than 20 percent by weight of cementitious material and the content of OPC shall not be less than 120 kg/cu.m.

If this minimum is not sufficient to produce dry lean concrete of the specified strength, it shall be increased as necessary by the Contractor at his own cost.

Concrete Strength

The average compressive strength of each consecutive group of 5 cubes made in accordance with Clause 903.5.1.1 shall not be less than 10 MPa at 7 days. In addition, the minimum compressive strength of any individual cube shall not be less than 7.5 MPa at 7 days. The design mix complying

with the above Clauses shall be got approved from the Engineer and demonstrated in the trial length construction.

Sub-grade

The sub-grade shall conform to the grades and cross-sections shown on the drawings and shall be laid and compacted in accordance with Clause 305. The subgrade strength shall

correspond to the design strength specified in the Contract. As far as possible, the construction traffic shall be avoided on the prepared sub-grade.

Drainage Layer

A drainage layer conforming to Clause 401 shall be laid above the subgrade before laying the Dry Lean Concrete sub-base, as specified in the drawings and the Contract.

Construction

General

The Dry Lean Concrete shall be laid on the prepared granular drainage layer. The pace and programme of the Dry Lean Concrete sub-base construction shall be matching suitably with the programme of construction of the cement concrete pavement over it. The Dry Lean Concrete sub-base shall be overlaid with concrete pavement only after 7 days of sub-base construction.

Batching and Mixing

The batching plant shall be capable of proportioning the materials by weight, each type of material being weighed separately in accordance with Clauses 602.9.2, 602.9.3.1 and 602.9.3.2.

The design features of Batching Plant should be such that the plant can be shifted quickly.

Transporting

Plant mix lean concrete shall be discharged immediately from the mixer, transported directly to the point where it is to be laid and protected from the weather by covering the tipping trucks with tarpaulin during transit. The concrete shall be transported by tipping trucks, sufficient in number to ensure a continuous supply of material to feed the laying equipment to work at a uniform speed and in an uninterrupted manner. The lead of the batching plant to paving site shall be such that the travel

time available from mixing to paving as specified in Clause 601.6.5.2 will be adhered to. Tipping truck shall not have old concrete sticking to it. Each tipping truck shall be washed with water jet before next loading as and when required after inspection.

Placing

Lean concrete shall be placed by a paver with electronic sensor on the drainage layer or as specified in the Contract. The equipment shall be capable of laying the material in one layer

in an even manner without segregation, so that after compaction the total thickness is as specified. The paving machine shall have high amplitude tamping bars to give good initial compaction to the sub-base. One day before placing of the dry lean cement concrete sub- base, the surface of the granular sub-base/drainage layer shall be given a fine spray of water and rolled with a smooth wheeled roller.

Preferably the lean concrete shall be placed and compacted across the full width of the two lane carriageway, by constructing it in one go. In roads with carriageway more than 2 lanes a longitudinal joint shall be provided. Transverse butt type joint shall be provided at the end of the construction in a day. Transverse joints in the concrete pavement shall not be continuous with the transverse construction joint of the Dry Lean Concrete.

The Dry Lean Concrete shall be laid in such a way that it is at least 750 mm wider on each side than the proposed width including paved shoulders of the concrete pavement. The actual widening shall be decided based on the specifications of the paver, such that the crawler moves on the Dry Lean Concrete, and the cost of extra width shall be borne by the Contractor.

Compaction

The compaction shall be carried out immediately after the material is laid and levelled. In order to ensure thorough compaction, rolling shall be continued on the full width till there is no further visible movement under the roller and the surface is well closed. The minimum dry density obtained shall not be less than 98 percent of that achieved during the trial length construction in accordance with Clause 601.7. The densities achieved at the edges i.e. 0.5 m from the edge shall not be less than 96 percent of that achieved during the trial construction.

The spreading, compacting and finishing of the lean concrete shall be carried out as rapidly as possible and the operation shall be so arranged as to ensure that the time between the mixing of the first batch of concrete in any transverse section of the layer and

the final finishing of the same shall not exceed 90 minutes when the temperature of concrete is between 25°C and 30°C, and 120 minutes if less than 25°C. This period may be reviewed by the Engineer in the light of the results of the trial run but in no case shall it exceed 120 minutes. Work shall not proceed when the temperature of the concrete exceeds 30°C. If necessary, chilled water or addition of ice may be resorted to for bringing down the temperature. It is desirable to stop concreting when the ambient temperature is above 35°C. After compaction has been completed, roller shall not stand on the compacted surface for the duration of the curing period except during commencement of next day's work near the location where work was terminated the previous day.

Double drum smooth-wheeled vibratory rollers of minimum 80 to 100 kN

static weight are suitable for rolling dry lean concrete. In case any other roller is proposed, the same shall be got approved from the Engineer, after demonstrating its performance. The number of passes required to obtain maximum compaction depends on the thickness of the dry lean concrete, the compactibility of the mix and the weight and type of the roller and the same as well as the total requirement of rollers for the jobs shall be determined during trial run by measuring in-situ density and the scale of the work to be undertaken.

Except on super elevated portions where rolling shall proceed from the inner edge to the outer, rolling shall begin from the edges gradually progressing towards the centre. First, the edge/edges shall be compacted with a roller running forward and backward. The roller shall then move inward parallel to the centerline of the road, in successive passes uniformly lapping preceding tracks by at least one half width.

A preliminary pass without vibration to bed the Dry Lean Concrete down shall be given followed by the required number of passes to achieve the desired density and, a final pass without vibration to remove roller with vibration marks and to smoothen the surface.

Special care and attention shall be exercised during compaction near joints, kerbs, channels, side forms and around gullies and manholes. In case adequate compaction is not achieved by the roller at these locations, use of plate vibrators shall be made, if so directed by the Engineer.

The final lean concrete surface on completion of compaction shall be well closed, free from movement under roller and free from ridges, low spots, cracks, loose material, pot holes, ruts or other defects. The final surface shall be inspected immediately on completion and all loose, segregated or defective areas shall be corrected by using fresh lean concrete material, laid and compacted. For repairing honeycombed/hungry surface, concrete with aggregates of size 10 mm and below shall be spread and compacted as per Specifications. It is necessary to check the level of the rolled surface for compliance. Any level/thickness deficiency shall be corrected after applying

concrete with aggregates of size 10 mm and below after roughening the surface. Surface regularity also shall be checked with 3 m straight edge. Strength tests shall be carried out, and if deficiency in strength is noticed, at least three (evenly spread) cores of minimum 100 mm dia per km shall be cut to check deficiency in strength. The holes resulting from cores shall be restored by filling with concrete of the specified strength and compacted by adequate rodding.

Segregation of concrete in the tipping trucks shall be controlled by moving the dumper back and forth while discharging the mix into the same or by any appropriate means. Paving operation shall be such that the mix does not segregate.

Joints

Construction and longitudinal joints shall be provided as per the drawings.

Transverse butt type joint shall be provided at the end of the construction in a day. Longitudinal construction joint shall be provided only when full width paving is not possible. Transverse joints in Dry Lean concrete shall be staggered from the construction butt type joint in Concrete pavement by 800-1000 mm.

Longitudinal joint in Dry Lean Concrete shall be staggered by 300-400 mm from the longitudinal joint of concrete pavement.

At longitudinal or transverse construction joints, unless vertical forms are used, the edge of compacted material shall be cut back to a vertical plane where the correct thickness of the properly compacted material has been obtained.

Curing

As soon as the lean concrete surface is compacted, curing shall commence. One of the following methods shall be adopted:

- a) Curing may be done by covering the surface by gunny bags/hessian, which shall be kept wet continuously for 7 days by sprinkling water.
- b) The curing shall be done by spraying with approved resin based aluminized reflective curing compound conforming to ASTM-C 309-81 in accordance with Clause 602.9.12. As soon as the curing compound has lost its tackiness, the surface shall be covered with wet hessian for three days. The rate of application shall be as recommended by the supplier.
- c) Wax-based white pigmented curing compound with water retention index of not less than 90 percent shall be used to cure the dry lean concrete. The curing compound shall

conform to BS:7542. The compound shall be applied uniformly with a mechanical sprayer and with a hood to protect the spray from the wind. The curing compound shall be applied over the entire exposed surface of the Dry Lean Concrete, including sides and edges, at the rate of 0.2 litres/sq.m, or as recommended by the supplier.

The first application, referred to as curing application shall be applied immediately after the final rolling of Dry Lean Concrete is completed. As soon as the curing compound loses tackiness, the surface shall be covered with wet hessian for three days. The second application of curing compound also referred to as the debonding application, shall be applied 24 to 48 hours prior to the placement of the concrete pavement. Any damaged Dry Lean Concrete shall be corrected prior to the second application. Normally, the manufacturer's instructions shall be followed for its application.

Trial Mixes

The Contractor shall make trial mixes of dry lean concrete with moisture contents like 5.0, 5.5, 6.0, 6.5 and 7.0 percent using specified cement content, specified aggregate grading and aggregate-cement ratio specified in Clause 601.3.1. Optimum moisture and density shall be established by preparing cubes with varying moisture contents. Compaction of the mix shall be done in three layers with vibratory hammer fitted with a square or rectangular foot as described in Clause 903.5.1.1. After establishing the optimum moisture, a set of six cubes shall be cast at optimum moisture for the determination of compressive strength on the third and the seventh day. Trial mixes shall be repeated if the strength is not satisfactory by increasing cement content. After the mix design is approved, the Contractor shall construct a trial section in accordance with Clause 601.8.

If during the construction of the trial length, the optimum moisture content determined as above is found to be unsatisfactory, the Contractor may make suitable changes in the moisture content to achieve the satisfactory mix. The cube specimens prepared with the changed mix content should satisfy the strength requirement. Before production of the mix, natural moisture content of the aggregate should be determined on a day-to-day basis so that the moisture content could be adjusted. The mix finally designed should neither stick to the rollers nor become too dry resulting in ravelling of surface.

Trial Length

The trial length shall be constructed at least 14 days in advance of the proposed date of commencement of work. At least 30 days prior to the construction of the trial length, the Contractor shall submit for the Engineer's approval a "Method Statement" giving detailed description of the proposed materials, plant, equipment, mix proportions, and procedure for batching, mixing, laying, compaction and other construction procedures. The Engineer shall also approve the location and length of trial construction which shall be a minimum of 100 m length laid in two days and for full width of the pavement. The trial length shall be outside the

main works. The trial length shall contain the construction of at least one transverse construction joint involving hardened concrete and freshly laid Dry Lean Concrete sub-base. The construction of trial length shall be repeated till the Contractor proves his ability to satisfactorily construct the Dry Lean Concrete sub-base.

After the construction of the trial length, the in-situ density of the freshly laid material shall be determined by sand replacement method. Three density holes shall be made at locations equally spaced along a diagonal that bisects the trial length and average of these densities shall be determined. The density holes shall not be made in the strip 500 mm from the edges. The average density obtained from the three samples collected shall be the reference density and is considered as 100 percent. The field density of regular work will be compared with this reference density in accordance with Clauses 601.6.5.1 and 903.5.1.2.

The hardened concrete shall be cut over 3 m width and reversed to inspect the bottom surface for any segregation taking place. The trial length shall be constructed after making necessary changes in the gradation of the mix to eliminate segregation of the mix. The lower surface shall not have honey-combing and the aggregates shall not be held loosely at the edges.

The main work shall not start until the trial length has been approved by the Engineer. After approval has been given, the materials, mix proportions, moisture content, mixing, laying, compaction plant and construction procedures shall not be changed without the approval of the Engineer.

Tolerances for Surface Regularity, Level, Thickness, Density and Strength

Control of quality of materials and works shall be exercised by the Engineer in accordance with Section 900.

Traffic

No heavy commercial vehicles like trucks and buses shall be permitted on the dry lean concrete sub-base. Construction vehicles at slow speed may be permitted after 7 days of its construction with the prior approval of the Engineer.

Measurement for Payment

The unit of measurement for dry lean concrete pavement shall be in cubic metre of concrete placed, based on the net plan area for the accepted thickness shown on the drawings or as directed by the Engineer.

Rate

The Contract unit rate payable for dry lean concrete sub-base shall be for carrying out the required operations including full compensation for all labour, materials and equipment, mixing, transport, placing, compacting, finishing, curing, rectification of defective surface testing and incidentals such as trial length to complete the work as per Specifications, all royalties, fees, storage and rents where necessary and all leads and lifts.

602 CEMENT CONCRETE PAVEMENT

Scope

The work shall consist of construction of un-reinforced, dowel jointed, plain

cement concrete pavement in accordance with the requirements of these Specifications and in conformity with the lines, grades and cross sections shown on the drawings. The work shall include furnishing of all plant and equipment, materials and labour and performing all operations in connection with the work, as approved by the Engineer.

The design parameters, viz., thickness of pavement slab, grade of concrete, joint details etc. shall be as stipulated in the drawings.

Materials

Source of Materials

The Contractor shall indicate to the Engineer the source of all materials to be used in the concrete work with relevant test data sufficiently in advance, and the approval of the Engineer for the same shall be obtained at least 45 days before the scheduled commencement of the work in trial length. If the Contractor subsequently proposes to obtain materials from a different source during the execution of main work, he shall notify the Engineer, with relevant test data, for his approval, at least 45 days before such materials are to be used.

Cement

Any of the following types of cement capable of achieving the design strength may be used with prior approval of the Engineer, but preference shall be to use at least the 43 grade or higher.

S.No.	Type	Conforming to
i)	Ordinary Portland Cement 43 Grade	IS:8112
ii)	Ordinary Portland Cement 53 Grade	IS:12269
iii)	Portland slag cement	IS:455
iv)	Portland Pozzolana Cement	IS:1489-Part I

If the soil around concrete pavement has soluble salts like sulphates in excess of 0.5 percent, the cement used shall be sulphate resistant and shall conform to IS:12330.

Cement to be used may preferably be obtained in bulk form. If cement in paper bags is proposed to be used, there shall be bag-splitters with the facility to separate pieces of paperbags and dispose them off suitably. No paper pieces shall enter the concrete mix. Bulk cement shall be stored in accordance with Clause 1014. The cement shall be subjected to acceptance test.

Fly-ash upto 20 percent by weight of cementitious material may be used in Ordinary Portland

Cement 43 and 53 Grade as part replacement of cement provided uniform blending with cement is ensured. The fly ash shall conform to IS:3812 (Part I).

Site mixing of fly ash shall be permitted only after ensuring availability of the equipments at site for uniform blending through a specific mechanised facility with automated process control like batch mix plants conforming to IS:4925 and IS:4926. Site mixing will not be allowed otherwise.

The Portland Pozzolana Cement produced in factory as per IS:1489-Part I shall not have fly-ash content more than 20 percent by weight of cementitious material. Certificate from the manufacturer to this effect shall be produced before use.

Chemical Admixtures

Admixtures conforming to IS:9103 and IS:6925 shall be permitted to improve workability of the concrete and/or extension of setting time, on satisfactory evidence that they will not have any adverse effect on the properties of concrete with respect to strength, volume change, durability and have no deleterious effect on steel bars. The particulars of the admixture and the quantity to be used, must be furnished to the Engineer in advance to obtain his approval before use. Satisfactory performance of the admixtures should be proved both on the laboratory concrete trial mixes and in the trial length paving. If air entraining admixture is used, the total quantity of air shall be 5 ± 1.5 percent for 31.5 mm maximum nominal size aggregate (in air-entrained concrete as a percentage of the volume of the mix).

Silica Fumes

Silica fume conforming to a standard approved by the Engineer may be used as an admixture in the proportion of 3 to 10 percent of cement. Silica fume shall comply with the requirements given in IS:15388-2003, IS:456-2000, IRC:SP:76 and IRC:44-2008.

Fibres

Fibres may be used subject to the provision in the design/approval by the Engineer to reduce the shrinkage cracking and post-cracking. The fibres may be steel fibre as per IRC:SP:46 or polymeric Synthetic fibres within the following range of specifications:

Effective Diameter	10 micron – 100 micron
Length	6-48 mm
Specific gravity	more than 1.0
Suggested dosage	0.6-2.0 kg/cu.m (0.2 - 0.6% by weight of cement in mix) Usage will be regulated as stipulated in IRC:44/IS:456
Water absorption	less than 0.45 percent
Melting point of this fibre shall not be less than 160°C.	
The aspect ratio generally varies from 200 to 2000.	
These synthetic fibres will have good alkali and UV light resistance.	

When fibres are used, the mix shall be so designed that the slump of concrete at paving site is 25±15 mm.

Aggregates

Aggregates for pavement concrete shall be natural material complying with IS:383 but with a Los Angeles Abrasion Test value not exceeding 35 percent. The limits of deleterious materials shall not exceed the requirements set out in Table 600-2.

Table 600-2 : Permissible Limits of Deleterious Substances in Fine and Coarse Aggregates

S. No.	Deleterious Substance	Method of Test	Fine Aggregate Percentage by Weight, (Max)		Coarse Aggregate Percentage by Weight (Max)	
			Uncrushed	Crushed*	Uncrushed	Crushed*
(1)	(2)	(3)	(4)	(5)	(6)	(7)
i)	Coal and lignite	IS:2386 (Part II)-1963	1.0	1.0	1.0	1.0
ii)	Clay lumps	do	1.0	1.0	1.0	1.0
iii)	Materials finer than 75 μ IS Sieve	IS:2386 (Part I)-1963	3.0	8.0	3.0	3.0
iv)	Soft fragments	IS:2386 (Part II)-1963	–	–	3.0	–
v)	Shale	IS:2386 (Part II)-1963	1.0	–	–	–
vi)	Total of percentages of all deleterious materials (except mica) including SI No. (i) to (v) for col 4, 6 and 7 and SI No. (i) and (ii) for col 5 only		5.0	2.0	5.0	5.0

* Crushed aggregate at least one face fractured

Note: The presence of mica in the fine aggregate has been found to reduce considerably the durability and compressive strength of concrete and further investigations are underway to determine the extent of the deleterious effect of mica. It is advisable, therefore, to investigate the mica content of fine aggregate and make suitable allowances for the possible reduction in the strength of concrete or mortar; in cases where the stretch of the project road passes through micaceous belt.

The aggregates shall be free from chert, flint, chalcedony or other silica in a form that can react with the alkalis in the cement. In addition, the total chlorides content expressed as chloride ion content shall not exceed 0.06 percent by weight and the total sulphate content expressed as sulphuric anhydride (SO₃) shall not exceed 0.25 percent by weight. In case the Engineer considers that the aggregates are not free from dirt, the same may be washed and drained for atleast 72 hours before batching, as directed by the Engineer.

Coarse Aggregates

Coarse aggregates shall consist of clean, hard, strong, dense, non-porous and durable pieces of crushed stone or crushed gravel and shall be devoid of pieces of disintegrated stone, soft, flaky, elongated, very angular or splintery pieces. The maximum size of coarse aggregate shall not exceed 31.5 mm for pavement concrete. No aggregate which has water absorption more than 2 percent shall be used in the concrete mix. The aggregates shall be tested for soundness in accordance with IS:2386 (Part-5). After 5 cycles of testing, the loss shall not be more than 12 percent if sodium sulphate solution is used or 18 percent if magnesium sulphate solution is used. The Los Angeles Abrasion value shall not exceed 35. The combined flakiness and elongation index of aggregate shall not be more than 35 percent.

Fine Aggregates

The fine aggregates shall consist of clean natural sand or crushed stone sand or a combination of the two and shall conform to IS:383. Fine aggregate shall be free from soft particles, clay, shale, loam, cemented particles, mica and organic and other foreign matter. The fine aggregates shall have a sand equivalent value of not less than 50 when tested in accordance with the requirement of IS:2720 (Part 37).

Combined Gradation of Fine and Coarse Aggregates

The combined gradation of fine and coarse aggregates shall be as per Table 600-3.

Table 600-3 : Aggregate Gradation for Pavement Quality Concrete

Sieve Designation	Percentage by Weight Passing the Sieve
31.5 mm	100
26.5 mm	85-95
19.0 mm	68-88
9.5 mm	45-65
4.75 mm	30-55
600 micron	8-30
150 micron	5-15
75 micron	0-5

Water

Water used for mixing and curing of concrete shall be clean and free from injurious amount of oil, salt, acid, vegetable matter or other substances harmful to the finished concrete. It shall meet the requirements stipulated in IS:456.

Steel for Dowels and Tie Bars

Steel shall conform to the requirements of IS:432 and IS:1786 as relevant. The dowel bars shall conform to IS:432 of Grade I. Tie bars shall be either High yield Strength Deformed bars conforming to IS:1786 and grade of Fe 500 or plain bars conforming to IS:432 of Grade I. The steel shall be coated with epoxy paint for protection against corrosion.

Joint Filler Board

Synthetic Joint filler board for expansion joints shall be used only at abutting structures like bridges and shall be of 20-25 mm thickness within a tolerance of ± 1.5 mm and of a firm compressible material and complying with the requirements of IS:1838, with a compressibility more than 25 percent. It shall be 25 mm less in depth than the thickness of the slab within a tolerance of ± 3 mm and provided to the full width between the side forms. It shall be in suitable lengths which shall not be less than one lane width. If two pieces are joined to make up full width, the joint shall be taped such that no slurry escapes through the joint. Holes to accommodate dowel bars shall be accurately bored or punched out to give a sliding fit on the dowel bars.

Joint Sealing Compound

The joint sealing compound shall be of hot poured, elastomeric type or cold polysulphide/polyurethane/silicone type having flexibility, resistance to age hardening and durability as per IRC:57. Manufacturer's certificate shall be produced by the Contractor for establishing that the sealant is not more than six months old and stating that the sealant complies with the relevant standard mentioned below. The samples shall meet the requirements as mentioned in IRC:57.

If sealant is of hot poured type, it shall conform to

Hot applied sealant : IS:1834 or ASTM : 3406-95, as applicable
Cold

poured sealants shall be one of the following :

- | | | |
|------|--------------|--------------------------------------|
| i) | polysulphide | IS:11433 (Part I), BS:5212 (Part II) |
| ii) | polyurethane | BS:5212 |
| iii) | silicone | ASTM 5893-04 |

Preformed Seals

The pre-formed joint sealing material shall be a vulcanized elastomeric compound using polychloroprene (Neoprene) as the base polymer.

The joint seal shall conform to requirements of ASTM D 2628 as given in Table 600-4.

Table 600-4 : Requirement of Preformed Seals as per ASTM D 2628

S. No.	Description	Requirements	ASTM Test Methods
1)	Tensile strength, min	13.8 MPa	D 412
2)	Elongation at break	Min. 250%	D 412
3)	Hardness, Type A durometer	55 +/-5 points	D 2240
4)	Oven aging, 70 h at 100°C Tensile strength loss	20% max	D 573
5)	Elongation loss	20% max	
6)	Hardness Change Type A durometer	0 to +10 points	D 471
7)	Oil Swell, ASTM Oil 3, 70 h at 100°C Weight Change	45% max	D 1149
8)	Ozone resistance 20 percent strain, 300 pphmin air, 70 h at 40°C	No cracks	D 2240
9)	Low temperature stiffening, 7 days at -10°C Hardness Change type A durometer	0 to +15 points	
10)	Low temperature recovery, 22h at -10°C, 50% deflection	88% min	D 2628
11)	Low temperature recovery, 22h at -29°C, 50% deflection	83% min	D 2628
12)	Low temperature recovery, 70h at -100°C, 50% deflection	85% min	D 2628
13)	Compression, deflection, at 80% of normal width (min)	613 N/m	D 2628

Storage of Materials

All materials shall be stored in accordance with the provisions of Clause 1014 of the Specifications. All efforts shall be made to store the materials in proper places so as to prevent their deterioration or contamination by foreign matter and to ensure their satisfactory quality and fitness for the work. The platform where aggregates are stock piled shall be paved and elevated from the ground at least by 150 mm. The area shall have slope to drain off rain water. The storage space must also permit easy

inspection, removal and storage of the materials. Aggregates of different sizes shall be stored in partitioned stack-yards. All such

materials even though stored in approved godowns must be subjected to acceptance test as per Clause 903 of these Specifications prior to their use.

Proportioning of Concrete

After approval by the Engineer of all the materials to be used in the concrete, the Contractor shall submit the mix design based on weighed proportions of all ingredients for the approval of the Engineer vide Clause 602.3.4. The mix design shall be submitted at least 30 days prior to the paving of trial length and the design shall be based on laboratory trial mixes using the approved materials and methods as per IRC:44 or IS:10262. The target mean strength for the design mix shall be determined as indicated in Clause 602.3.3.1. The mix design shall be based on the flexural strength of concrete.

Cement Content

When Ordinary Portland Cement (OPC) is used the quantity of cement shall not be less than 360 kg/cu.m. In case fly ash grade I (as per IS:3812) is blended at site as part replacement of cement, the quantity of fly ash shall be upto 20 percent by weight of cementitious material and the quantity of OPC in such a blend shall not be less than 310 kg/cu.m. The minimum of OPC content, in case ground granulated blast furnace slag cement blended, shall also not be less than 310 kg/m³. If this minimum cement content is not sufficient to produce concrete of the specified strength, it shall be increased as necessary by the contractor at his own cost.

Concrete Strength

The characteristic flexural strength of concrete shall not be less than 4.5 MPa unless specified otherwise. Target mean flexural strength for mix design shall be more than $4.5 \text{ MPa} + 1.65s$, where s is standard deviation of flexural strength derived by conducting test on minimum 30 beams. While designing the mix in the laboratory, correlation between flexural and compressive strengths of concrete shall be established on the basis of at least thirty tests on specimens. However, quality control in the field shall be exercised on the basis of flexural strength. It may, however, be ensured that the materials and mix proportions remain substantially unaltered during the daily concrete production. The water content shall be the minimum required to provide the agreed workability for full compaction of the concrete to the required density as determined by the trial mixes or as approved by the Engineer and the maximum free water cement ratio shall be 0.45 when only OPC is used and 0.50 when blended cement (Portland Pozzolana Cement or Portland Slag Cement or OPC blended with fly ash or Ground Granulated Blast Furnance Slag, at site) is used.

The ratio between the 7 and 28 day strength shall be established for the mix to be used in the slab in advance, by testing pairs of beams and cubes at each stage on at least six batches of trial mix. The average strength of the 7 day cured specimens shall be divided by the average strength of the 28 day specimens for each batch, and the ratio 'R' shall be determined. The ratio 'R' shall be expressed to three decimal places.

If during the construction of the trial length or during some normal working, the average value of any four consecutive 7 day test results falls below the required 7 day strength as derived from the value of 'R' then the cement content of the concrete shall, without extra payment, be increased by 5 percent by weight or by an amount agreed by the Engineer. The increased cement content shall be maintained at least until the four corresponding

28 day strengths have been assessed for in conformity with the requirements as per Clause 602.3.3.1. Whenever the cement content is increased, the concrete mix shall be adjusted to maintain the required workability.

Workability

The workability of the concrete at the point of placing shall be adequate for the concrete to be fully compacted and finished without undue flow. The optimum workability for the mix to suit the paving plant being used shall be determined by the Contractor and approved by the Engineer. The control of workability in the field shall be exercised by the slump test as per IS:1199.

The workability requirement at the batching and mixing plant and paving site shall be established by slump tests carried during trial paving. These requirements shall be established from season to season and also when the lead from batching and mixing plant site to the paving site changes. The workability shall be established for the type of paving equipment available. A slump value in the range of 25 ± 15 mm is reasonable for paving works but this may be modified depending upon the site requirement and got approved by the Engineer. These tests shall be carried out on every tipping truck/dumper at batching and mixing plant site and paving site initially when the work commences but subsequently the frequency can be reduced to alternate tipping trucks or as per the instructions of the Engineer.

Design Mix

The Contractor shall carry out laboratory trials of design mix with the materials from the approved sources to be used as per IRC:44. Trial mixes shall be made in presence of the Engineer or his representative and the design mix shall be subject to the approval of the Engineer. They shall be repeated, if necessary, until the proportions, that will produce a concrete which complies in all respects with these Specifications, and conform to the requirements of the design/drawings.

The proportions determined as a result of the laboratory trial mixes may be adjusted, if necessary, during the construction of the trial length. Thereafter, neither the materials nor the mix proportions shall be varied in any way except with the written approval of the Engineer.

Any change in the source of materials or mix proportions proposed by the Contractor during the course of work shall be assessed by making laboratory trial mixes and the construction of a further trial length of length not less than 50 m unless approval is given by the Engineer for minor adjustments like compensation for moisture content in aggregates or minor fluctuations in the grading of aggregate.

Sub-base

The cement concrete pavement shall be laid over the sub-base constructed in accordance with the relevant drawings and Specifications. It shall be ensured that the sub-base is not damaged before laying the concrete pavement. If the dry lean concrete sub-base is found damaged at some places or it has cracks wider than 10 mm, it shall be repaired with fine cement concrete (aggregate size 10 mm and down) or bituminous concrete before laying separation membrane layer.

Separation Membrane

A separation membrane shall be used between the concrete slab and the sub-base. Separation membrane shall be impermeable PVC sheet 125 micron thick transparent or white in colour laid flat with minimum creases. Before placing the separation membrane, the sub-base shall be swept clean of all the extraneous materials using air compressor. Wherever overlap of plastic sheets is necessary, the same shall be at least 300 mm and any damaged sheathing shall be replaced at the Contractor's cost. The separation membrane may be nailed to the lower layer with concrete nails. The separation membrane shall be omitted when two layers of wax-based curing compound is used.

Joints

The locations and type of joints shall be as shown in the drawing. Joints shall be constructed depending upon their functional requirement. The location of the joints should be transferred accurately at the site and mechanical saw cutting of joints done as per stipulated dimensions. It shall be ensured that the required depth of cut is made from edge-to-edge of the pavement. Transverse and longitudinal joints in the pavement and Dry Lean Concrete sub-base shall be staggered so that they are not coincident vertically and are at least 800 to 1000 mm and 300 to 400 mm apart respectively. Sawing of joints shall be carried out with diamond studded blades soon after the concrete has hardened to take the load of the sawing machine and crew members without damaging the texture of the pavement.

Sawing operation could start as early as 4-8 hours after laying of concrete pavement but not later than 8 to 12 hours depending upon the ambient temperature, wind velocity, relative humidity and required maturity of concrete achieved for this purpose.

When the kerb is cast integrally with the main pavement slab, the joint cutting shall also be extended to the kerb.

Where the use of maturity meter is specified, sawing should not be initiated when the compressive strength of the concrete is less than 2 MPa and should be completed before it attains the compressive strength of 7 MPa.

Transverse Joints

Transverse joints shall be contraction, construction and expansion joints constructed at the spacing described in the drawings. Transverse joints shall be straight within the following tolerances along the intended line of joints.

- i) Deviations of the performed filler board (IS:1838) in the case of expansion joints from the intended line of the joint shall not be greater than ± 10 mm.
- ii) The best fit straight line through the joint grooves as constructed shall be not more than 25 mm from the intended line of the joint
- iii) Deviations of the joint groove from the best fit straight line of the joint shall not be greater than 10 mm.
- iv) Transverse joints on each side of the longitudinal joint shall be in line with each other and of the same type and width. Transverse joints shall have a sealing groove which shall be sealed in compliance with Clause 602.10.

Contraction Joints

The contraction joints shall be placed transversely at pre-specified locations as per drawings/design using dowel bars. These joints shall be cut as soon as the concrete has undergone initial hardening and is hard enough to take the load of joint sawing machine without causing damage to the slab.

Contraction joints shall consist of a mechanical sawn joint groove, 3 to 5 mm wide and one-fourth to one-third depth of the slab ± 5 mm or as stipulated in the drawings and dowel bars complying with Clause 602.6.5.

Contraction joint shall be widened subsequently to accommodate the sealant as per Clause 602.10, to dimensions shown on drawings or as per IRC:57.

Expansion Joints

The expansion joint shall consist of a joint filler board complying with Clause 602.2.9 and dowel bars complying with Clause 602.6.5 and as detailed in the drawings. The filler board shall be positioned vertically with the prefabricated joint assemblies along the line of the

joint within the tolerances given in Clause 602.6.2.1. The adjacent slabs shall be completely separated from each other by the joint filler board.

Transverse Construction Joint

Transverse construction joint shall be placed whenever concreting is completed after a day's work or is suspended for more than 30 minutes. These joints shall be provided at location of contraction joints using dowel bars. If sufficient concrete has not been mixed to form a slab extending upto a contraction joint, and if an interruption occurs, the concrete placed shall be removed upto the last preceding joint and disposed of. At all construction joints, steel bulk heads shall be used to retain the concrete. The surface of the concrete laid subsequently shall conform to the grade and cross sections of the previously laid pavement. When positioning of bulk head/stop-end is not possible, concreting to an additional 1 or 2 m length may be carried out to enable the movement of joint cutting machine so that joint grooves may be cut and the extra 1 or 2 m length is cut out and removed subsequently after concrete has hardened.

After minimum 14 days of curing, in case OPC cement is used and 16 days of curing when flyash or blended cement is used, the construction joint shall be widened to accommodate the sealant as per Clause 602.10 to dimensions shown on drawing or as per IRC:57.

Longitudinal Joint

The longitudinal joints shall be constructed by forming or by sawing as per details of the joints shown in the drawing. Sawed longitudinal joints shall be constructed when the concrete pavement placement width exceeds 4.5 m. The groove may be cut after the final set of the concrete. Joints should be sawn to at least one-third the depth of the slab ± 5 mm as indicated in the drawing. The joint shall be widened subsequently to dimensions shown on the drawings.

Where adjacent lanes of pavement are constructed separately using slip form pavers or side forms, the tie bars may be bent at right angles against the vertical face/ side of the first lane constructed and

straightened before placing concrete in the adjacent lane. Broken or damaged tie bars shall be repaired or replaced as required.

The groove for sealant shall be cut in the pavement lane placed later.

Tie Bars

Tie bars shall be provided at the longitudinal joints as per dimensions and spacing shown in the drawing and in accordance with Clause 602.6.6. The direction of the tie bars at curves shall be radial in the direction of the radius.

Dowel Bars

Dowel bars shall be mild steel rounds in accordance with Clause 602.2.8 with details/dimensions as indicated in the drawings and free from oil, dirt, loose rust or scale. They shall be straight, free of irregularities and burring restricting slippage in the concrete. The sliding ends shall be sawn or cropped cleanly with no protrusions outside the normal diameter of the bar. Any protrusions shall be removed by grinding the ends of the dowel bars. The dowel bar shall be supported on cradles/dowel chairs in pre-fabricated joint assemblies positioned prior to the construction of the slabs or mechanically inserted with vibration into the plastic concrete by a method which ensures correct placement of the bars besides full re-compaction of the concrete around the dowel bars.

Unless shown otherwise on the drawings, dowel bars shall be positioned at mid depth of the slab within a tolerance of ± 20 mm, and centered equally about intended lines of the joint within a tolerance of ± 25 mm. They shall be aligned parallel to the finished surface of the slab and to the centre line of the carriageway and to each other within tolerances given here-in-under, the compliance of which shall be checked as per Clause 602.11.7.

- i) For bars supported on cradles prior to the laying of the slab:
 - a) All bars in a joint shall be within ± 2 mm per 300 mm length of bar
 - b) 2/3rd of the number of bars shall be within ± 3 mm per 500 mm length of bar
 - c) No bar shall differ in alignment from an adjoining bar by more than 3 mm per 300 mm length of bar in either the horizontal or vertical plane
 - d) Cradles supporting dowel bar shall not extend across the line of joint i.e. no steel bar of the cradle assembly shall be continuous across the joint.
- ii) For all bars inserted after laying of the slab except those inserted by a Dowel

Bar Insert the tolerance for alignment may be twice as indicated in (i) above.

The transverse joints at curves shall be radial in the direction of the radius.

Dowel bars, supported on cradles in assemblies, when subject to a load of 110 N applied at either end and in either the vertical or horizontal direction (upwards and downwards and in both directions horizontally) shall conform to be within the limits given in Clause 602.6.5.2.

The assembly of dowel bars and supporting cradles, including the joint filler board in the case of expansion joints, shall have the following degree of rigidity when fixed in position:-

- i) For expansion joints, the deflection of the top edge of the filler board shall be not greater than 13 mm, when a load of 1.3 kN is applied perpendicular to the vertical face of the joint filler board and distributed over a length of 600 mm by means of a bar or timber packing, at mid depth and midway between individual fixings, or 300 mm from either end of any length of filler board, if a continuous fixing is used. The residual deflection after load shall be not more than 3 mm.
- ii) The fixings for joint assembly shall not fail under 1.3 kN load and shall fail before the load reaches 2.6 kN when applied over a length of 600 mm by means of a bar or timber packing placed as near to the level of the line of fixings as practicable.
- iii) Fixings shall be deemed to fail when there is displacement of the assemblies by more than 3 mm with any form of fixing, under the test load. The displacement shall be measured at the nearest part of the assembly to the centre of the bar or timber packing.

Dowel bars in the contraction joints, construction joints and expansion joints shall be covered by a thin plastic sheath. The thickness of the sheath shall not exceed

0.5 mm and shall be tightly fitted on the bar for at least two-thirds of the length from one end for dowel bars in contraction/construction joints and half the length plus 50 mm for expansion joints. The sheathed bar shall comply with the following pull-out tests:

Four bars shall be taken at random from stock and without any special preparation shall be covered by sheaths as required in this Clause. The ends of the dowel bars which have been sheathed shall be cast centrally into concrete specimens 150 mm x 150 mm x 600 mm, made of the same mix proportions to be used in the pavement, but with a maximum nominal aggregate size of 20 mm and cured in accordance with IS:516. At 7 days a tensile load shall be applied to achieve a movement of the bar of at least 0.25 mm. The average bond stress to achieve this movement shall not be greater than 0.14 MPa.

For expansion joints, a closely fitting cap 100 mm long consisting of waterproofed cardboard or an approved synthetic material like PVC or GI pipe shall be placed over the sheathed end of each dowel bar. An expansion space (about 25 mm) at least equal in length to the thickness of the joint filler board shall be formed between the end of the cap and the end of the dowel bar by using compressible sponge. To block the entry of cement slurry into the annular space between the

sheathing and dowel bar shall be taped around its mouth.

Tie Bars

Tie bars in longitudinal joints shall be deformed steel bars of strength 500 MPa complying with IS:1786 and in accordance with the requirements given in this Clause. The bars shall be free from oil, dirt, loose rust and scale.

Tie bars projecting across the longitudinal joint shall be protected from corrosion for 75 mm on each side of the joint by a protective coating of bituminous paint with the approval of the Engineer. The coating shall be dry when the tie bars are used. In the case of coastal region and high rainfall areas, tie bars shall be epoxy coated in their full length as per IS:13620.

Tie bars in longitudinal joints shall be made up into rigid assemblies with adequate supports and fixings to remain firmly in position during the construction of the slab. Alternatively, tie bars at longitudinal joints may be mechanically or manually inserted into the plastic concrete from above by vibration using a method which ensures correct placements of the bars and recompaction of the concrete around the tie bars.

Tie bars shall be positioned to remain in the middle from the top or within the upper middle third of the slab depth as indicated in the drawings and approximately parallel to the surface and approximately perpendicular to the line of the joint, with the centre of each bar on the intended line of the joints within a tolerance of ± 50 mm, and with a minimum cover of 30 mm below the joint groove. Spacing of tie bars on curves of radius less than 360 m shall not be less than 350 mm.

To check the position of the tie bars, one metre length, 0.5 m on either side of the longitudinal joint shall be opened when the concrete is green (within 20 to 30 minutes). The pit shall be refilled with the fresh concrete of same mix after checking.

Weather and Seasonal Limitations

Concreting during Monsoon Months

Concreting should be avoided during rainy season. However, when concrete is being placed during monsoon months and when it may be expected to rain, sufficient supply of tarpaulin or other waterproof cloth shall be provided along the line of the work. Any time when it rains, all freshly laid concrete which had not been covered for curing purposes shall be adequately protected. Any concrete damaged by rain shall be removed and replaced. If the damage is limited to texture, it shall be retextured in accordance with the directions of the Engineer.

Temperature Limitation

No concreting shall be done when the temperature of the concrete reaching the paving site is above 30°C. Besides, in adverse conditions like high temperature, low relative humidity, excessive wind velocity, imminence of rains etc., tents on mobile trusses may be provided over the freshly laid concrete for a minimum period of 3 hours as directed by the Engineer. To bring down the temperature, if necessary, chilled water or ice flakes should be made use of. When the ambient temperature is more than 35°C, no concreting shall be permitted. The ice flakes should not be manufactured from chlorinated water. Generally the rate of evaporation of water shall not exceed 1 kg/sqm/hour as per IRC:15.

No concreting shall be done when the concrete temperature is below 5°C and the temperature is further falling.

Fixed Form Paving

Side Forms and Rails

These shall be provided in case of fixed form paving. All side forms shall be of mild steel of depth equal to the thickness of pavement or slightly less to accommodate the surface irregularity of the sub-base. The forms can be placed in series of steel packing plates or shims to take care of irregularity of sub-base. They shall be sufficiently robust and rigid to support the weight and pressure caused by a paving equipment. Side forms for use with wheeled paving machines shall incorporate metal rails firmly fixed at a constant height below the top of the forms. The forms and rails shall be firmly secured in position by not less than 3 stakes/pins for every 3 m length so as to prevent movement in any direction. Forms and rails shall be straight within a tolerance of 3 mm in 3 m and when in place shall not settle in excess of 1.5 mm in 3 m while paving is being done. Forms shall be cleaned and oiled immediately before each use. The forms shall be bedded on a continuous bed of low moisture content lean cement mortar or concrete and set to the line and levels shown on the drawings within tolerances ± 10 mm and ± 3 mm respectively. The bedding shall not extend under the slab and there shall be no vertical step between adjacent forms of more than 3 mm. The forms shall be got inspected by the Engineer for his approval 12 hours before construction of the slab and shall not be removed until at least 12 hours afterwards. No concreting shall commence till formwork has been approved by the Engineer.

At all times sufficient forms shall be used and set to the required alignment for at least 300 m length of pavement immediately in advance of the paving operations, or the anticipated length of pavement to be laid within the next 24 hours whichever is more.

Slip Form Paving

Use of Guide wires

Where slip form paving is proposed, a guide wire shall be provided along both sides of the slab. Each guide wire shall be at a constant height above and parallel to the required edges of the slab as described in the contract drawing within a vertical tolerance of ± 3 mm. Additionally, one of the wires shall be kept at a constant horizontal distance from the required edge of the pavement as indicated in the contract drawing within a lateral tolerance of ± 10 mm. Concrete Pavement Section 600

The guide wires shall be supported on stakes 5–6 m apart by connectors capable of fine horizontal and vertical adjustment. The guidewire shall be tensioned on the stakes so that a 500 gm weight shall produce a deflection of not more than 20 mm when suspended at the mid point between any pair of stakes. The ends of the guidewires shall be anchored to fixing point or winch and not on the stakes. On the curves, the stakes shall be fixed at not more than 3 m centre-to-centre.

The stakes shall be positioned and hammered into the ground and the connectors will be maintained at their correct height and alignment from 12 hours on the day before concreting takes place till after finishing of texturing and spraying of curing compound on the concrete.

However, the guidewire shall be erected and tensioned on the connectors at any section for at least 2 hours before concreting that section.

The Contractor shall submit to the Engineer for his approval of line and level, the stakes and connectors which are ready for use in the length of road to be constructed next day. Such approval shall be obtained at least 12 hours before commencement of paving operation. Any deficiencies noted by the Engineer shall be rectified by the Contractor who shall then re-apply for approval of the affected stakes. Work shall not proceed until the Engineer has given his approval. It shall be ensured that the stakes and guidewires are not affected by the construction equipment when concreting is in progress.

Construction

General

A systems approach may be adopted for construction of the pavement, and the Method Statement for carrying out the work, detailing all the activities, indication of time-cycle, equipment, personnel etc., shall be got approved from the Engineer before the commencement of the work. This shall include the type, capacity and make of the batching and mixing plant besides the hauling arrangement and

paving equipment. The capacity of paving equipment, batching plant as well as all the ancillary equipment shall be adequate for a paving rate of at least 500 m in one day. The paving speed of slip-form paver shall not be less than 1.0 m per minute. The concreting should proceed continuously without stops and starts.

Batching and Mixing

Batching and mixing of the concrete shall be done at a central batching and mixing plant with automatic controls, located at a suitable place which takes into account sufficient space for stockpiling of cement, aggregates and stationary water tanks. This shall be located at an approved distance, duly considering the properties of the mix and the transporting arrangements available with the Contractor.

Equipment for Proportioning of Materials and Paving

Proportioning of materials shall be done in the batching plant by weight, each type of material being weighed separately. The cement from the bulk stock may be weighed separately from the aggregates. Water shall be measured by volume. Specified percentage of plasticizer in volume will be added by weight of cement. Wherever properly graded aggregate of uniform quality cannot be maintained as envisaged in the mix design, the grading of aggregates shall be controlled by appropriate blending techniques. The capacity of batching and mixing plant shall be at least 25 percent higher than the proposed capacity of the laying/paving equipment.

Batching Plant and Equipment :

- 1) **General** : The batching plant shall include minimum four bins, weighing hoppers, and scales for the fine aggregates and for each size of coarse aggregate. If cement is used in bulk, a separate scale for cement shall be included. There shall be a separate bin for flyash, if this additive is specified. The weighing hoppers shall be properly sealed and vented to preclude dust during operation. Approved safety devices shall be provided and maintained for the protection of all personnel engaged in plant operation, inspection and testing. The batch plant shall be equipped with a suitable non-resettable batch counter which will correctly indicate the number of batches proportioned. A continuous type of mixing plant can also be used provided the ingredients are weighed through electronic sensors before feeding.
- 2) **Automatic weighing devices** : Batching plant shall be equipped to proportion aggregates and bulk cement by means of automatic weighing devices using load cells. The weighing devices shall have an accuracy within $\pm 1\%$ in respect of quantity of cement, admixtures and water and

±2% in respect of aggregates and the accuracy shall be checked at least once a month.

- 3) **Mixer** : Mixers shall be pan type, reversible type or any other mixer capable of combining the aggregates, cement, and water into a thoroughly mixed and uniform mass within the specified mixing period, and of discharging the mix, without segregation. Each stationary mixer shall be equipped with an approved timing device which will automatically lock the discharge lever when the drum has been charged and release it at the end of the mixing period. The device shall be equipped with a bell or other suitable warning device adjusted to give a clearly audible signal each time the lock is released. In case of failure of the timing device, the mixer may be used for the balance of the day while it is being repaired, provided that each batch is mixed in 90 seconds or as per the manufacturer's recommendation. The mixer shall be equipped with a suitable non-resettable batch counter which shall correctly indicate the number of batches mixed.

The mixer shall be cleaned at suitable intervals. The pick-up and throw-over blades in the drum or drums shall be repaired or replaced when they are worn down 20 mm or more. The Contractor shall (1) have available at the job site a copy of the manufacturer's design, showing dimensions and arrangements of blades in reference to original height and depth, or (2) provide permanent marks on blade to show points of 20 mm wear from new conditions. Drilled holes of 5 mm diameter near each end and at midpoint of each blade are recommended. Batching Plant shall be calibrated in the beginning and thereafter at suitable interval not exceeding 1 month.

- 4) **Control cabin** : An air-conditioned centralized computer control cabin shall be provided for automatic operation of the equipment.
- 5) The design features of the batching plant should be such that it can be shifted quickly.

Paving Equipment

The concrete shall be placed with an approved fixed form or slip form paver with independent units designed to (i) spread, (ii) consolidate, screed and float-finish, (iii) texture and cure the freshly placed concrete in one complete pass of the machine in such a manner that a minimum of hand finishing will be necessary and so as to provide a dense and homogeneous pavement in conformity with the plans and Specifications. The paver shall be equipped with electronic sensor controls to control the line and grade from either one side or both sides of the machine.

Vibrators shall operate at a frequency of 8000-10000 impulses per minute under load at a maximum spacing of 600 mm. The variable vibration setting shall be provided in the machine.

Concrete Saw

The Contractor shall provide adequate number of concrete saws with sufficient number of diamond-edge saw blades. The saw machine shall be either electric or petrol/diesel driven type. A water tank with flexible hose and pump shall be made available for this activity on priority basis. The Contractor shall have at least one standby saw in good working condition. The concreting work shall not commence if the saws are not in working condition.

Hauling and Placing of Concrete

Freshly mixed concrete from the central batching and mixing plant shall be transported to the paver site by means of tipping trucks or transit mixers of sufficient capacity and approved design in sufficient numbers to ensure a constant supply of concrete. Covers shall be used for protection of concrete against the weather. While loading the concrete truck shall be moved back and forth under the discharge chute to prevent segregation. The tipping trucks shall be capable of maintaining the mixed concrete in a homogeneous state and discharging the same without segregation and loss of cement slurry. The feeding to the paver is to be regulated in such a way that the paving is done in an uninterrupted manner with a uniform speed throughout the day's work. Tipping trucks shall be washed at a regular frequency as prescribed by the Engineer to ensure that no left-over mix of previous loading remains stuck.

Placing of Concrete

The total time taken from the addition of the water to the mix, until the completion of the surface finishing and texturing shall not exceed 120 minutes when concrete temperature is less than 25°C and 90 minutes when the concrete temperature is between 25°C and 30°C. When the time between mixing and laying exceed these values, the concrete shall be rejected and removed from the site. Tipping trucks delivering concrete shall normally not run on plastic sheathing nor shall they run on completed slabs until after 28 days of placing the concrete.

The placing of concrete in front of the PQC paver should preferably be from the side placer to avoid damage to DLC by concrete tipping trucks. In case of unavoidable situation, truck supplying concrete to the paver may be allowed to ply on the DLC with the approval of the Engineer. The paver shall be capable of paving the carriageway as shown in the drawings, in a single pass and lift.

Where fixed form pavers are to be used, forms shall be fixed in advance as per Clause 602.8. Before any paving is done, the site shall be shown to the Engineer, in order to verify the arrangement for paving besides placing of dowels, tie-bars etc., as per the relevant Clauses of these Specifications. The mixing and placing of concrete shall progress only at such a rate as to permit proper finishing, protecting and curing of the concrete in the pavement.

In areas inaccessible to paving equipment, the pavement shall be constructed using side forms, as per Clause 602.9.7.

In all cases, the temperature of the concrete shall be measured at the point of discharge from the delivery vehicle.

The addition of water to the surface of the concrete to facilitate the finishing operations will not be permitted except with the approval of the Engineer when it shall be applied as a mist by means of approved equipment.

If considered necessary by the Engineer, the paving machines shall be provided with approved covers to protect the surface of the slab under construction from direct sunlight and rain or hot wind.

While the concrete is still plastic, its surface shall be textured by brush or tines as per the instructions of the engineer in compliance with Clause 602.9.11. The surface and edges of the slab shall be cured by the application of a sprayed liquid curing membrane in compliance with Clause 602.9.12. After the surface texturing, but before the curing compound is applied, the concrete slab shall be marked with the chainage at every 100 m interval by embossing.

As soon as the side forms are removed, edges of the slabs shall be corrected wherever irregularities have occurred by using fine concrete composed of 1:1:2, cement : sand : coarse agg (10 mm down) with water cement ratio not more than 0.4 under the supervision of the Engineer.

If the requirement of Clause 902.4. for surface regularity fails to be achieved on two consecutive working days, then normal working shall cease until the cause of the excessive irregularity has been identified and remedied.

Construction by Slip Form Paver

The slip form paving train shall consist of a power machine which spreads, compacts and finishes the concrete in a continuous operation. The slip form paving machine shall compact the concrete by internal vibration and shape it between the side forms with either a conforming plate or by vibrating and oscillating finishing beams. The concrete shall be deposited without segregation in front of slip form paver across the whole width and to a height which at all times is in excess of the required surcharge. The deposited concrete shall be struck off to the necessary average and differential surcharge by means of the strike off plate or a screw auger device extending across the whole width of the slab. The equipment for striking-off the concrete shall be capable of being rapidly adjusted for changes of the average and differential surcharge necessitated by change in slab thickness or cross fall.

The level of the conforming plate and finishing beams shall be controlled automatically from the guide wires installed as per Clause 602.8 by sensors attached at the four corners of the slip form paving machine. The alignment of the paver shall be controlled automatically from the guide wire by at least one set of sensors attached to the paver. The alignment and level of ancillary machines for finishing, texturing and curing of the concrete shall be automatically controlled relative to the guide wire or to the surface and edge of the slab.

Slip-form paving machines shall have vibrators of variable output, with a maximum energy output of not less than 2.5 KW per metre width of slab per 300 mm depth of slab for a laying speed upto 1.5 m per minute. The machines shall be of sufficient mass to provide adequate reaction during spreading and paving operations on the traction units to maintain forward movements during the placing of concrete in all situations. Normal paving speed shall be maintained as per Clause 602.9.1.

If the edges of the slip formed slab slump to the extent that the surface of the top edge of the slab does not comply with the requirements of Clause 902.3, the work shall be stopped until such time as the Contractor can demonstrate his ability to slip form the edges to the required levels. The deficient edge shall be temporarily supported by a side form and the thickness deficiency shall be made good by adding fresh concrete to the newly formed edge and compacting.

Slip-form pavers with adequate width to pave the entire carriageway width in one go shall be employed unless specified in the Contract. In situations where full-width paving is not possible, paving in part widths may be permitted by the Engineer. Paving in part will be avoided, except in unavoidable circumstances. In case of part width paving, care shall be taken to ensure that while laying the next lane, bond between the remaining half length of tie bar or subsequently inserted tie bars and the newly laid concrete is adequately developed. Care shall be taken to avoid damage to the previous lane.

In case paving in separate lanes is allowed, work on the adjacent lane shall be permitted when the previously paved lane is cured for at least 14 days and is in a position to bear the weight of paving machine. When the wheels or crawler tracks are to ply on the already paved surface, necessary precautions shall be taken by placing protective pads of rubber or similar material so that texture is not damaged. The wheel or track shall be reasonably away from the edge to avoid damage to the previously laid slab.

Tube Floating

Upon the instructions of the Engineer, Contractor shall scrape the concrete surface when in plastic state with a 3 m long tube float fixed with a long and stable handle before texturing. Tube float shall be of an alloy steel tube of 50 to 60 mm diameter with a long and stable handle. The length of tube float shall preferably be longer than half the length of slab i.e., half the distance between two transverse contraction joints. This operation shall be done to minimise surface irregularity caused

due to varied causes like frequent stoppages of work, surface deformation due to plastic flow etc. The tube float shall be placed at the centre of the slab parallel to longitudinal joint and pulled slowly and uniformly towards the edges. After the use of float tube, it shall be frequently cleaned before further use. The slurry removed shall be discarded. This activity shall be advanced laterally by providing an overlap of half the length of tube float. The removal of the cement slurry from the surface shall be sufficient enough such that the texture is formed on a firm surface and is more durable. This operation, however, shall be carried out after removing bleeding water.

Construction by Fixed Form Paver

The fixed form paving train shall consist of separate powered machines which spread, compact and finish the concrete in a continuous operation.

The concrete shall be discharged without segregation into a hopper spreader which is equipped with means for controlling its rate of deposition on to the sub-base. The spreader shall be operated to strike off concrete upto a level requiring a small amount of cutting down by the distributor of the spreader. The distributor of spreader shall strike off the concrete to the surcharge adequate to ensure that the vibratory compactor thoroughly compacts the layer. If necessary, poker vibrators shall be used adjacent to the side forms and edges of the previously constructed slab. The vibratory compactor shall be set to strike off the surface slightly high so that it is cut down to the required level by the oscillating beam. The machine shall be capable of being rapidly adjusted for changes in average and differential surcharge necessitated by changes in slab thickness or crossfall. The final finisher shall be able to finish the surface to the required level and smoothness as specified, care being taken to avoid bringing up of excessive mortar to the surface by over working.

Semi-mechanised Construction

Areas in which hand-guided methods of construction become indispensable shall be got approved by the Engineer in writing in advance. Such work may be permitted only in restricted areas in small lengths. Work shall be carried out by skilled personnel as per methods approved by the Engineer. The acceptance criteria regarding level, thickness, surface regularity, texture, finish, strength, of concrete and all other quality control measures shall be the same as in the case of machine laid work. Guidelines on the use of plants, equipment, tools, hauling of mix, compaction floating, straight edging, texturing, edging etc. shall be as per IRC:15.

Transition Slabs

At the interface of rigid and flexible pavement, at least 3 m long reinforced buried slab shall be provided to give a long lasting joint at the interface. The details shall be as given in IRC:15.

Anchor Beam and Terminal Slab Beam Adjoining Bridge Structures

RCC anchor beams shall be provided in the terminal slab adjoining bridge structures as per drawings and IRC:15.

The Treatment of Concrete Pavement on Culverts

The concrete pavement shall be taken over the culverts. At both ends of the culvert slab, a contraction joint shall be provided in the concrete pavement. Nominal reinforcement of 10 mm dia bars at 150 mm spacing in both directions shall be provided at 50 mm below the top of the slab. The reinforcement shall be stopped 50 mm short of the contraction joint. Such reinforcement shall also be provided in the next slab panel on either side.

Surface Texture

Tinning

After final floating and finishing of the slab and before application of the liquid curing membrane, the surface of concrete slabs shall be textured either in the transverse direction (i.e., at right angles to the longitudinal axis of the road) or in longitudinal direction (i.e., parallel to the centreline of the roadway). The texturing shall be done by tining the finished concrete surface by using rectangular steel tines. A beam or a bridge mounted with steel tines shall be equipped and operated with automatic sensing and control devices from main paver or auxiliary unit. The tining unit shall have facility for adjustment of the download pressure on the tines as necessary to produce the desired finish. The tining rakes shall be cleaned often to remove spots of slurry. The tines shall be inspected daily and all the damaged and bent tines shall be replaced before commencing texturing. Tined grooves shall be 3 mm wide and 3 to 4 mm deep. Before commencing texturing, the bleeding water, if any, shall be removed and texturing shall be done on a firm surface. The measurement of texture depth shall be done as per Clause 602.12.

- a) **Transverse tining** : When the texturing is specified in transverse direction, a beam of at least 3 m length mounted with tines shall be moved in transverse direction to produce the texture. The grooves produced shall be at random spacing of grooves but uniform in width and depth. The spacing shall conform to a pattern shown below:

Random spacing in mm

10	14	16	11	10	13	15	16	11	10	21	13	10
----	----	----	----	----	----	----	----	----	----	----	----	----

The above pattern shall be repeated. Texturing shall be done at the right time such that the grooves after forming shall not close and they shall not get roughened. Swerving of groove patterns will not be permitted. The completed textured surface shall be uniform in appearance.

- b) **Longitudinal tining** : Longitudinal tining shall be done, if specified in the Contract. The texturing bridge shall be wide enough to cover the entire width of the carriageway but within 75 mm from the pavement edge. The centre to centre spacing between the tines shall be 18 to 21 mm. The width of tine texture shall be 3 mm and depth shall be 3 to 4 mm.

Brush Texturing

Alternatively on the instructions of the Engineer, the brush texturing shall be applied. The brushed surface texture shall be applied evenly across the slab in one direction by the use of a wire brush not less than 450 mm wide but wider brushes normally of 3 m length are preferred. The brush shall be made of 32 gauge tape wires grouped together in tufts placed at 10 mm centres. The tufts shall contain an average of 14 wires and initially be 100 mm long. The brush shall have two rows of tufts. The rows shall be 20 mm apart and the tufts in one row shall be opposite the centre of the gap between tufts in the other row. The brush shall be replaced when the shortest tuft wears down to 90 mm long.

The texture depth shall be determined by the Sand Patch Test as described in the Clause 602.12. This test shall be performed at least once for each day's paving and wherever the Engineer considers it necessary at times after construction as under:

Five individual measurements of the texture depth shall be taken at least 2 m apart anywhere along a diagonal line across a lane width between points 50 m apart along the pavement. No measurement shall be taken within 300 mm of the longitudinal edges of a concrete slab constructed in one pass.

Texture depths shall not be less than the minimum required depth when measurements are taken as given in Table 600-5 nor greater than an average of 1.25 mm.

Table 600-5 : Texture Depth

Time of Test		Number of Measurements	Required Texture Depth (mm)	
			Specified Value	Tolerance
1)	Between 24 hours and 7 days after the construction of the slab or until the slab is first used by vehicles	An average of 5 measurements	1.00	±0.25

2)	Not later than 6 weeks before the road is opened to traffic	An average of 5 measurements	1.00	+0.25 -0.35
----	---	------------------------------	------	----------------

After the application of the brushed texture, the surface of the slab shall have a uniform appearance.

Where the texture depth requirements are found to be deficient, the Contractor shall make good the texture across the full lane width over the length directed by the Engineer, by retexturing the hardened concrete surface in an approved manner.

Curing

Immediately after the surface texturing, the surface and sides of the slab shall be cured by the application of approved resin-based aluminized reflective curing compound which hardens into an impervious film or membrane with the help of mechanical sprayer.

The curing compound shall not react chemically with the concrete and the film or membrane shall not crack, peel or disintegrate within three weeks of application. Immediately prior to use, the curing compound shall be thoroughly agitated in its containers. The rate of spread shall be in accordance with the manufacturer's instructions checked during the construction of the trial length and subsequently whenever required by the Engineer. The mechanical sprayer shall incorporate an efficient mechanical device for continuous agitation and mixing of the compound during spraying. The curing compound shall be sprayed in two applications to ensure uniform spread.

Curing compounds shall contain sufficient flake aluminum in finely divided dispersion to produce a complete coverage of the sprayed surface with a metallic finish. The compound shall become stable and impervious to evaporation of water from the surface of the concrete within 60 minutes of application and shall be of approved type. The curing compounds shall have a water retention efficiency index not less than 90 percent in accordance with BS Specification No. 7542 or as per ASTM C-309-81 Type 2.

In addition to spraying of curing compound, the fresh concrete surface shall be protected for at least 3 hours by covering the finished concrete pavement with tents mounted on mobile trusses as described in Clause 602.7.2, during adverse weather conditions as directed by the Engineer. After three hours, the pavement shall be covered by moist hessian laid in two layers and the same shall then be kept damp for a minimum period of 14 days after which time the hessian may be removed. The hessian shall be kept continuously moist. All damaged/torn hessian shall be removed and replaced by new hessian on a regular basis.

The Contractor shall be liable at his cost to replace any concrete damaged as a result of incomplete curing or cracked on a line other than that of a joint as per procedure in IRC:SP:83.

Preparation and Sealing of Joint Grooves

General

All joints shall be sealed using sealants described in Clause 602.2.10.

Preparation of Joint Grooves for Sealing

Grooves are saw cut in the first instance just to provide minimum width(3-5 mm) to facilitate development of crack at joint locations, as shown in the drawing.

Subsequently before sealing, grooves are widened by sawing as per the dimensions in the drawing. Dimension of the grooves shall be controlled by depth/width gauge.

If rough arrises develop when grooves are made, they shall be ground to provide a chamfer approximately 5 mm wide. If the groove is at an angle upto 10° from the perpendicular to the surface, the overhanging edge of the groove shall be sawn or ground perpendicular. If spelling occurs or the angle of the former is greater than 10 degree, the

joint sealing groove shall be sawn wider and perpendicular to the surface to encompass the defects upto a maximum width, including any chamfer, of 20 mm for transverse joints and 10 mm for longitudinal joints. If the spelling cannot be so eliminated then the arises shall be repaired by an approved thin bonded arrises repair using cementitious/epoxy mortarmaterials.

All grooves shall be cleaned of any dirt or loose material by air blasting with filtered, oil-free compressed air. The Engineer shall instruct cleaning by pressurized water jets. Depending upon the requirement of the sealant manufacturer, the sides of the groove shall be sand blasted to increase the bondage between sealant and concrete.

The groove shall be cleaned and dried at the time of priming and sealing. If sand blasting is recommended by the supplier, the same shall be carried out.

Before sealing the temporary seal provided for blocking the ingress of dirt, soil etc., shall be removed. A highly compressible heat resistant paper-backed debonding strip as per drawing shall be inserted in the groove to serve the purpose of breaking the bond between sealant and the bottom of the groove and to plug the joint groove so that the sealant may not leak through the cracks. The width of debonding strip shall be more than the joint groove width so that it is held tightly in the groove. In the case of longitudinal joints, heat resistant tapes may be inserted to block the leakage through bottom of the joint where hot poured sealant is used. When cold poured sealant is used a debonding tape of 1.0-2.0 mm thickness and 6 to 8 mm width shall be inserted to plug the groove so that the sealant does not enter in the initially cut groove.

Sealing with Sealants

When sealants are applied, an appropriate primer shall also be used if recommended by the manufacturer and it shall be applied in accordance with his instructions. The sealant shall be applied within the minimum and maximum drying times of the primer recommended by the manufacturer.

Priming and sealing with applied sealants shall not be carried out when the naturally occurring temperature in the joint groove to be sealed, is below 7°C.

If hot applied sealant is used it shall be heated and applied from a thermostatically controlled, indirectly heated preferably with oil jacketed melter and pourer having recirculating pump and extruder. For large road projects, sealant shall be applied with extruder having flexible hose and nozzle. The sealant shall not be heated to a temperature higher than the safe heating temperature and not for a period longer than the safe heating period, as specified by the manufacturer. The dispenser shall be cleaned out at the end of each day in accordance with the manufacturer's recommendations and reheated material shall not be used. The Movement Accommodation Factor of the sealant shall be more than 10 percent.

Cold applied sealants with chemical formulation like polysulphide/ polyurethane/ silicone as per IRC:57 shall be used. These shall be mixed and applied within the time limit specified by the manufacturer. If primers are recommended they shall be applied neatly with an appropriate brush. The Movement Accommodation Factor shall be more than 25 percent.

The sealants applied at contraction phase of the slabs would result in bulging of the sealant over and above the slab. Therefore, the Contractor in consultation with the Engineer, shall establish the right temperature and time for applying the sealant. Thermometers shall be hung on a pole at the site for facilitating control during the sealing operation.

Sealant shall be applied, slightly to a lower level than the slab with a tolerance of 3 ± 1 mm.

During sealing operation, it shall be seen that no air bubbles are introduced in the sealant either by vapours or by the sealing process. The sealant after pouring, shall be allowed to cure for 7 days or for a period as per instructions of manufacturers.

Trial Length

The trial shall be constructed at least one month in advance of the proposed start of concrete paving work. At least one month prior to the construction of the trial length, the Contractor shall submit for the Engineer's approval a detailed method statement giving description of the proposed materials, plant, equipment and construction methods. All the major equipments like paving train, batching plant, tipping trucks etc., proposed in the construction are to be approved by the Engineer before their procurement. No trials of new materials, plant, equipment or construction methods, nor any development of them shall be permitted either during the construction of trial length or in any subsequent paving work, unless they form part of further trials. The trial lengths shall be constructed away from the carriageway.

The Contractor shall demonstrate the materials, plant, equipment and methods of construction that are proposed for concrete paving, by first constructing a trial length of slab, at least 100 m long for mechanised construction and at least 50 m long for hand guided methods. The width of the trial section shall be the full carriageway width as shown in the drawings. If the first trial is unsatisfactory, the Contractor shall have to demonstrate his capability to satisfactorily construct the

pavement in subsequent trials.

The trial length shall be constructed in two parts over a period comprising at least part of two separate working days, with a minimum of 50 m constructed each day for mechanised construction and a minimum of 25 m on each day for hand guided construction. The trial length shall be constructed at a paving rate which is proposed for the main work.

Transverse joints including expansion joint and longitudinal joint that are proposed in the main work shall be constructed and assessed in the trial length.

The trial length shall comply with the Specifications in all respects including the test requirement of Table 900-6 with the following additions.

Surface Levels and Regularity

- a) In checking for compliance with Clause 902.3 the levels shall be taken at intervals at the locations specified in this Clause along any line or lines parallel to the longitudinal centre line of the trial length.
- b) The maximum number of permitted irregularities of pavement surface shall comply with the requirements of Clause 902.4. Shorter trial lengths shall be assessed pro-rata based on values for a 300 m length.

Joints

- a) Alignment of dowel bars shall be inspected in any two consecutive transverse joints in a trial length construction by removing the fresh concrete in a width of 0.5 m on either side of the joint. The joint pit shall be refilled with freshly prepared concrete, after inspection. Alternatively, it can be tested by suitable device like MIT SCAN with the permission of the Engineer. If the position or alignment of the dowel bars at one of these joints does not comply with the requirements and if that joint remains the only one that does not comply after the next 3 consecutive joints of the same type have been inspected, then the method of placing dowels shall be deemed to be satisfactory. In order to check sufficient joints for dowel bar alignment without extending the trial length unduly joints may be constructed at more frequent joint intervals than the normal spacing required in trial slabs.
- b) If there are deficiencies in the first expansion joint that is constructed as a trial, the next expansion joint shall be a trial joint. Should this also be deficient, further trial of expansion joints shall be made as part of the trial length which shall not form part of the permanent works, unless agreed by the Engineer.

Density

In-situ density in trial length shall be assessed as described in Clause 903.5.2.2 from at least 3 cores drilled from each part of the trial length when the concrete is not less than 7 days old. Should any of the cores show honey-combing in the concrete, the trial length shall be rejected and the construction

in the main carriageway shall not be permitted until further trials have shown that modification has been made which would result in adequate compaction.

Strength

Minimum of thirty (30) beams for flexural strength and thirty (30) cubes for compressive strength shall be prepared from the concrete delivered in front of the paving plant. Each pair of beams and cubes shall be from the same location/batch but different sets of beams and cubes shall be from different locations/batches. Compressive and flexural strength shall be tested after 28 days water curing in the laboratory.

At the age of 28 days, thirty (30) cores with diameter 150 mm shall be cut from the pavement slab when the thickness of concrete pavement is more than 300 mm. In case the concrete pavement thickness is less than 300 mm, the dia of core shall be 100 mm. The cores shall be suitably cut at both ends to provide a specimen of plain surface on both ends. The dia to height ratio of core shall be 1 to 2. For cylindrical specimen of PQC of dia 150 mm, the variation in dia shall be ± 0.5 mm, a tolerance on height shall be ± 1 mm for a specimen of height 300 mm or more. For cylindrical specimen of dia 100 mm, the variation in dia shall be ± 0.3 mm, and a tolerance on height shall be ± 1 mm for a specimen height of 200 mm. The compressive strength test shall be conducted as per IS:516.

Concrete in the member represented by a core test shall be considered acceptable, if the average equivalent cube strength of the cores is equal to at least 85 percent of the cube strength (characteristic strength) of the grade of the concrete specified for the corresponding age of 28 days and no individual core has a strength less than 75 percent.

202.11.6 Approval and Acceptance

Approval of the materials, plant, equipment and construction methods shall be given when the trial length complies with the Specifications. The Contractor shall not proceed with normal working until the trial length has been approved. If the Engineer does not notify the Contractor of any deficiencies in any trial length within 7 days after the completion of that trial length, the Contractor may assume that the trial length, and the materials, plant, equipment and construction methods adopted are acceptable, provided that the 28 days strength of cubes and cores extracted from trial length meet the requirement of the Specified strength.

When approval has been given, the materials, plant, equipment and construction methods shall not thereafter be changed, except for normal adjustments and maintenance of plant, without the approval of the Engineer. Any changes in materials, plant, equipment, and construction methods shall entitle the Engineer to require the Contractor to lay a further trial length as described in this Clause to demonstrate that the changes will not adversely affect the permanent works.

Trial lengths which do not comply with the Specifications, with the exception of areas which are deficient only in surface texture and which can be remedied in accordance with Clause 602.9.11.6

shall be removed immediately upon notification of deficiencies by the Engineer and the Contractor shall construct a further trial length.

Inspection of Dowel Bars

Compliance with Clause 602.6.5. for the position and alignment of dowel bars at contraction and expansion joints shall be checked by measurements relative to the side forms or guide wires.

When the slab has been constructed, the position and alignment of dowel bars and any filler board shall be measured after carefully exposing them in the plastic concrete across the whole width of the slab. When the joint is an expansion joint, the top of the filler board shall be exposed sufficiently in the plastic concrete to permit measurement of any lateral or vertical displacement of the board. During the course of normal working, these measurements shall be carried out in the pavement section at the end of days work by extending slab length by 2 m. After sawing the transverse joint groove, the extended 2 m slab shall be removed carefully soon after concrete has set to expose dowels over half the length. These dowels can be tested for tolerances. This joint shall be treated as construction joint. The position of dowel bars in any type of transverse joint ie, contraction, construction or expansion can alternatively be tested by suitable device like MIT SCAN with the permission of the Engineer.

If the position and alignment of the bars in a single joint in the slab is unsatisfactory then the next two joints shall be inspected. If only one joint of the three is defective, the rate of checking shall be increased to one joint per day until the Engineer is satisfied that compliance is being achieved.

After the dowel bars have been examined, the remainder of the concrete shall be removed over a width of 500 mm on each side of the line of the joint and reinstated to the satisfaction of the Engineer. The dowels shall be inserted on both sides of the 1 m wide slab by drilling holes and grouting with epoxy mortar. Plastic sheath as per Clause 602.6.5.5 shall be provided on dowels on one of the joints. The joint groove shall be widened and sealed as per Clause 602.10.

Inspection of Tie Bars

To check the position of the tie bars, one metre length 0.5 m on either side of the longitudinal joint shall be opened when the concrete is green (within 20 to 30 minutes of its laying). The pit shall be refilled with the fresh concrete of same mix after checking.

Measurement of Texture Depth – Sand Patch Method

The following Apparatus shall be used:

- i) A cylindrical container of 25 ml internal capacity;
- ii) A flat wooden disc 64 mm diameter with a hard rubber disc, 1.5 mm thick, next to one face, the reverse face being provided with a handle;
- iii) Dry natural sand with a rounded particle shape passing a 300 micron IS sieve and retained on a 150 micron IS sieve.

Method

The surface to be measured shall be dried, any extraneous mortar and loose material removed and the surface swept clean using a wire brush both at right angles and parallel to the carriageway. The cylindrical container shall be filled with the sand, tapping the base 3 times on the surface to ensure compaction, and striking off the sand level with the top of the cylinder. The sand shall be poured into a heap on the surface to be treated. The sand shall be spread over the surface, working the disc with its face kept flat in a circular motion so that the sand is spread into a circular patch with the surface depressions filled with sand to the level of peaks.

The diameter of the patch shall be measured to the nearest 5 mm. The texture depth of concrete surface shall be calculated from $31000/(D \times D)$ mm where D is the diameter of the patch in mm.

Measurement of Texture Depth - Tining

The following apparatus shall be used :

- i) Tire Tread Depth Gauge
A stainless steel tire tread depth gauge with graduations with least count of 1.0 mm. The gauge end may be modified to measure depth of fine texture.
- ii) A stainless steel caliper to measure spacing of tines. If necessary the caliper may be modified to measure the spacing and width of tine texture. The gauge shall be used after making necessary calibration.
- iii) Wire brush
- iv) Corborundum stone
- v) Steel straight edge to remove snots etc. sticking to the surface. The straight edge may be of 6 x 25 x 300 mm size.

Test Section

A unit of testing shall be 75 m per lane. If the length of construction is less than 75 m it shall be taken as one unit.

Test Procedure

In each 75 m section, along the diagonal line, 10 points shall be selected for making check of depth, width and spacing of tine grooves. The surface where tests are to be conducted shall be cleared carefully with a wire brush or a steel straight edge or using a corborundum plate to remove any upward projection of concrete. When the base plate of the gauge is in contact with the concrete surface, the gauge shall be pressed to the bottom of groove and the depth shall be measured and recorded at this location. At the same location, the spacing of tines shall be measured to verify whether the pattern recommended in Clause 602.9.11.1 is complied or not.

The average of depth and width at 10 locations shall be calculated and recorded to the nearest 1 mm. The spacing of spectrum measured at 10 locations shall be recorded separately.

The average depth shall be 3 to 4 mm. When the depth is less than 2.5 mm and in excess of 4.5 mm, the Contractor shall stop concreting till he corrects his tine

brush or replaces it. The sensors associated with work shall be again calibrated to achieve the required texture. The textured groove less than 2.5 mm shall be re-grooved using concrete saw at the cost of Contractor. Variation in texture width in the range of 3+1 mm and 3 - 0.5 mm will be acceptable. If the variation of width is in excess of this range, the Contractor shall stop work and correct the brush and technique. When the spacing of spectrum is not satisfactory, the Contractor shall replace the entire brush.

Opening to Traffic

No vehicular traffic shall be allowed to ply on the finished surface of a concrete pavement within a period of 28 days of its construction and until the joints are permanently sealed and cured. The road may be opened to regular traffic after completion of the curing period of 28 days and after sealing of joints is completed including the construction of shoulder, with the written permission of the Engineer.

Acceptance Criteria in Quality and Distress

- i) **Tolerances for Surface Regularity, Level, Thickness and Strength:** The tolerances for surface regularity, level, thickness and strength shall conform to the requirements given in Clause 903.5. Control of quality of materials and works shall be exercised by the Engineer in accordance with Section 900.
- ii) **Tolerances in Distress :** The acceptance criteria with regard to the types of distresses in rigid pavement shall be as per IRC:SP-83. "Guidelines for Maintenance, Repair and Rehabilitation of Cement Concrete Pavements". The cracks (of severity rating not more than 2) which may appear during construction or before completion of Defect Liability Period shall be acceptable with suggested treatments as given in IRC:SP-83.

Cement Concrete Pavement slabs having cracks of severity rating more than 2 i.e. cracks of width more than 0.5 mm for single discrete cracks, multiple and transverse cracks and cracks of width more than 3 mm in case of longitudinal cracks and of depth more than half of the concrete pavement slabs, shall be removed and replaced as per IRC:SP-83.

Measurements for Payment

Cement Concrete pavement shall be measured as a finished work in cubic metres of concrete placed based on the net plan area and thickness as measured in accordance with Clause 602.15.2.

The finished thickness of concrete for payment on volume basis shall be computed in the manner described in Clause 113.3 with the following modifications:

i) The levels shall be taken before and after construction at grid points 5 m centre to centre longitudinally in straight as well as at curves

ii) A day's work is considered as a 'lot' for calculating the average thickness of the slab. In calculating the average thickness, individual measurements which are in excess of the specified thickness by more than 10 mm shall be considered as the specified thickness plus 10 mm.

Individual areas deficient by more than 10 mm shall be verified by the Engineer by ordering core cutting and if in his opinion the deficient areas warrant removal, they shall be removed and replaced with concrete of the thickness shown on the plans.

Rate

The Contract unit rate for the construction of the cement concrete pavements shall be payment in full for carrying out the operations required for the different items of the work as per these Specifications including full compensation for all labour, tools, plant, equipment, providing all materials i.e. aggregates, dowel bars, tie bars, PVC membrane, cement, stabilizers (lime, cements or any other stabilizers approved by the Engineer), storing, mixing, transportation, placing, compacting, finishing, curing, testing, all royalties, fees, rents where necessary, all leads and lifts and incidentals to complete the work as per Specifications.

The unit rate shall all include the full costs of construction, expansion, contraction and longitudinal joints including joint filler, sealant, primer, debonding strip and all other operations for completing the work. The construction and testing of trial length shall be included in the contract unit rate for the pavement and shall not be paid separately.

Where the average thickness for the lot is deficient by the extent shown in Table 600-6, payment for cement concrete pavement shall be made at a price determined by adjusting the contract unit price as per Table 600-6.

Table 600-6 : Payment Adjustment for Deficiency in Thickness

Deficiency in the Average Thickness of Day's Work	Percent of Contract Unit Price Payable
Up to 5 mm	100
6-10 mm	87

No additional payment shall be made for the extra thickness of the slab than shown on the drawings.

1000

**MATERIALS FOR
STRUCTURES**

1001 GENERAL

Materials to be used in the work shall conform to the specifications mentioned on the drawings, the requirements laid down in this section and specifications for relevant items of work.

If any material, not covered in these Specifications, is required to be used in the work, it shall conform to relevant Indian Standards, if there are any, or to the requirements specified by the Engineer.

1002 SOURCES OF MATERIALS

The Contractor shall identify the sources of materials like coarse aggregate and fine aggregate and notify the Engineer regarding the proposed sources prior to delivery.

Samples of materials from the source shall be tested in the presence of Engineer for conformity to specifications. It shall also be ensured that the variation in test results of different samples, is within acceptable limits.

For manufactured items like cement, steel reinforcement and pre-stressing strands, the contractor shall intimate the Engineer the details of the source, testing facilities available with the manufacturer and arrangements for transport and storage of material at site. If directed by the Engineer, the contractor shall furnish samples and test results of recently received material. The Engineer, at his discretion, in case of doubt, may require the contractor to test the materials in an independent laboratory approved by the Engineer and furnish test certificates. The cost of these tests shall be borne by the contractor. The sampling and testing procedures shall be as laid down in the relevant Indian Standards and where they are not available, the same shall be carried out as per the directions of the Engineer. Only materials from sources approved by the Engineer shall be brought to the site. If the material from the approved source proves unacceptable at any time, the contractor shall identify new sources of acceptable materials conforming to specifications.

If any proprietary items are proposed to be used in the works, they shall be governed by the provisions of Clause 115.4 of these Specifications.

1003 BRICKS

Burnt clay bricks shall conform to the requirements of IS:1077, except that the minimum compressive strength when tested flat, shall not be less than 8.4 MPa for individual bricks and mean strength not less than 10.5 MPa for a group of 5 specimens. They shall be free from cracks and flaws and nodules of free lime. The brick shall have smooth rectangular faces with sharp corners and emit a

clear ringing sound when struck. The size may be according to local practice with a tolerance of ± 5 percent.

1004 STONES AND BLOCKS

1004.1 Stones

Stones shall be of the type specified. They shall be hard, sound, free from cracks, decay and weathering and shall be freshly quarried from an approved quarry. Stones with round surfaces shall not be used.

The stones, when immersed in water for 24 hours, shall not absorb water of more than 5 percent of their dry weight when tested in accordance with IS:1124.

The length of stone shall not exceed three times its height and the width on the base shall not be greater than three-fourth of the thickness of the wall nor less than 150 mm.

1004.2 Blocks

Solid concrete blocks made of cement and suitable aggregates shall conform to relevant provisions of IS:2185 Part 1 in respect of dimension, mix, manufacturing, curing, drying and physical requirements. The minimum compressive strength of solid concrete blocks when tested as per IS:2185 Part 1 shall not be less than 10.5 MPa. Hollow light weight concrete blocks shall not be used in works.

The thickness of concrete block shall not be less than 200 mm and the width shall not be less than 200 mm. The density of concrete block shall not be less than 2.2 ton/cu.m.

1005 CAST IRON

Cast iron shall conform to IS:210. The grade number of the material shall not be less than 14.

1006 CEMENT

Cement to be used shall be any of the following types with the prior approval of the Engineer.

- a) Ordinary Portland cement, 33 Grade, conforming to IS:269.

- b) Ordinary Portland cement, 43 Grade, conforming to IS:8112.
- c) Ordinary Portland cement, 53 Grade, conforming to IS:12269.
- d) Sulphate resisting Portland cement, conforming to IS:12330.
- e) Portland Pozzolana cement (fly ash based) conforming to IS:1489 (Part 1)
- f) Portland slag cement conforming to IS:455
- g) Rapid Hardening Portland cement, conforming to IS:8041.
- h) Low heat Portland cement conforming to IS:12600

Cement of 33 grade conforming to IS:269 shall be used only after ensuring that the minimum required design strength can be achieved without exceeding the maximum permissible cement content of 450 Kg/cum of concrete (excluding any mineral admixture).

Cements of 43 and 53 grades conforming to IS:8112 and IS:12269 respectively may be used provided the minimum cement content mentioned elsewhere from durability considerations, is not reduced.

Sulphate resisting cement conforming to IS:12330 shall be used when sodium sulphate and magnesium sulphate are present in large enough concentration to be aggressive to concrete. The recommended threshold values as per IS:456 are: sulphate concentration in excess of 0.2 percent in surrounding soil or 300 ppm (0.03 percent) in ground water. Cement conforming to IS:12330 shall be carefully selected from strength considerations to ensure that the minimum required design strength can be achieved without exceeding the maximum permissible cement content of 450 kg/cum (excluding any mineral admixture).

Alternatively, Portland slag cement conforming to IS:455 with slag content more than 50 percent can be used instead of sulphate resisting cement when the sulphate content in the surrounding soil is less than 1 percent or the sulphate content in the ground water is less than 2500 ppm.

Cement conforming to IS:8041 shall be used only for precast concrete products after specific approval of the Engineer.

Total chloride content shall be 0.1 percent by mass of cement for the cement to be used in structures other than prestressed concrete structures and 0.05% by mass of cement in prestressed concrete structures. Also, total sulphur content calculated as sulphuric anhydride (SO_3) shall in no case exceed 3.5 percent.

Where chloride is encountered along with sulphates in soil or ground water, ordinary Portland cement with C_3A content from 5 to 8 percent shall be preferably used in concrete, instead of sulphate resisting cement.

Manufacturer's test certificate shall be submitted to the Engineer by the contractor for every consignment of cement. The certificate shall cover all the tests for chemical requirements, physical requirements and chloride content as per relevant codes as applicable.

Independent tests of samples drawn from the consignment, shall be carried out at the site laboratory or in an independent laboratory approved by the Engineer, immediately after

delivery. The following properties shall be tested:

- i) Compressive strength.
- ii) Setting time.

The cost of the tests shall be borne by the Contractor.

Cement in bags in local storage for more than 3 months after completion of tests, may be re-tested for compressive strength and setting times (initial and final) before use and may be rejected if it fails to conform to any of the requirements.

Lot size for independent testing of cement at site shall be the quantity received at site on any day, subject to a maximum of 500 tonnes.

1007 COARSE AGGREGATES

For plain and reinforced cement concrete (PCC and RCC) or prestressed concrete (PSC) works, coarse aggregates shall consist of clean, hard, strong, dense, non-porous and durable pieces of crushed stone, crushed gravel, natural gravel or a suitable combination thereof or other approved inert material. They shall not contain pieces of disintegrated stones, soft, flaky, elongated particles, salt, alkali, vegetable matter or other deleterious materials in such quantities as to reduce the strength and durability of the concrete, or to attack the steel reinforcement. Coarse aggregates having positive alkali-silica reaction shall not be used. All coarse aggregates shall conform to IS: 383 and tests for conformity shall be carried out as per IS:2386, Parts I to VIII.

The contractor shall submit for the approval of the Engineer, the entire information indicated in Appendix A of IS:383.

Maximum nominal size of coarse aggregate for various structural components in PCC, RCC or PSC, shall conform to Section 1700 of these Specifications.

The maximum value for flakiness index for coarse aggregate shall not exceed 35 percent.

The coarse aggregate shall satisfy the requirements of grading as given in Table 1000-1:

Table 1000-1 : Grading Requirements of Coarse Aggregate

IS Sieve Size	Percentage Passing for Graded Aggregate of Nominal Size		
	40 mm	20 mm	12.5 mm
63 mm	—	—	—
40 mm	95 – 100	100	—
20 mm	30 – 70	95 – 100	100
12.5 mm	—	—	90 – 100
10 mm	10 – 35	25 – 55	40 – 85
4.75 mm	0 – 5	0 – 10	0 – 10

1008 FINE AGGREGATES

For masonry work, sand shall conform to the requirements of IS:2116.

Natural sand, crushed stone sand or crushed gravel sand or a suitable combination of natural sand, crushed stone or gravel, shall be used as fine aggregates in plain, reinforced and prestressed concrete works. The fine aggregates shall be dense, durable, clean and free from veins and adherent coating and other deleterious substances. They shall not contain dust, lumps, soft or flaky materials, mica or other deleterious materials in such quantities as to reduce the strength and durability of the concrete, or to attack the embedded steel. Mechanised sand washing machines should be used to remove impurities from sand. Fine aggregates having positive alkali-silica reaction shall not be used. All fine aggregates shall conform to IS:383 and tests for conformity shall be carried out as per IS:2386, (Parts I to VIII). The Contractor shall submit to the Engineer the entire information indicated in Appendix A of IS:383. The fineness modulus of fine aggregate shall neither be less than 2.0 nor greater than 3.5.

Fine aggregate for structural concrete shall conform to the following grading requirements:

Table 1000-2 : Grading Requirements of Fine Aggregates

IS Sieve Size	Percent Passing for		
	Grading Zone I	Grading Zone II	Grading Zone III
10 mm	100	100	100
4.75 mm	90-100	90-100	90-100
2.36 mm	60-95	75-100	85-100
1.18 mm	30-70	55-90	75-100

600 micron	15-34	35-59	60-79
300 micron	5-20	8-30	12-40
150 micron	0-10	0-10	0-10

Note : When the grading falls outside the limits of any particular grading zone of sieves other than 600-micron IS Sieve by a total amount not exceeding 5 percent, it shall be regarded as falling within that grading zone. However for crushed stone sand, the permissible limit on 150-micron IS Sieve is increased to 20 percent. Reference shall be made to Clause: 4.3 of IS:383.

1009 STEEL

1009.1 Cast Steel

The use of cast steel shall be limited to bearings and other similar parts. Steel for castings shall conform to Grade 280-520N of IS:1030. In case where subsequent welding is unavoidable in the relevant cast steel components, the letter N at the end of the grade designation of the steel casting shall be replaced by letter W. To increase the corrosion resistance properties, 0.3% to 0.5% copper may be added.

1009.2 Steel for Prestressing

The prestressing steel shall conform to any one of the following standards:

- a) Plain hard drawn steel wire conforming to IS:1785 (Part I) and IS:1785 (Part II)
- b) Cold drawn indented wire conforming to IS:6003
- c) High tensile steel bar conforming to IS:2090
- d) Uncoated stress relieved strands conforming to IS:6006
- e) Uncoated stress relieved low relaxation seven ply strand conforming to IS:14268

Data in respect of modulus of elasticity, relaxation loss at 1000 hours, minimum ultimate tensile strength, stress strain curve etc. shall be obtained from the manufacturer. Pre-stressing steel shall be subjected to acceptance tests prior to actual use in the works.

1009.3 Reinforcement/Untensioned Steel

1009.3.1 Reinforcing Bars

For plain and reinforced cement concrete (PCC and RCC) or prestressed concrete (PSC) works, the reinforcement/unstressed steel as the case may be, shall consist of the following grades of reinforcing bars.

Table 1000-3 : Grades of Reinforcing Bars

Grade Designation	Bar Type Conforming to Governing Specifications	IS Characteristic Strength f_y MPa	Elastic Modulus GP
Fe240	IS:432 Part I Mild Steel	240	200
Fe 415	IS:1786 High Strength Deformed Steel Bars (HSD)	415	200
Fe 500 or Fe 500D	IS:1786 High Strength Deformed Steel Bars (HSD)	500	200
Fe 550 or Fe 550D	IS:1786 High Strength Deformed Steel Bars (HSD)	550	200
Fe 600	IS:1786 High Strength Deformed Steel Bars (HSD)	600	200

Note : If any grade of steel given in the above table is not available steel of next higher grademay be used.

All steel shall be procured from ‘Original producers’ who manufacture billets directly from iron ores and roll the billets to produce steel conforming to IS:1786. No re-rolled steel shall be incorporated in the works. However, in case the original producers give certificate that they are unable to supply the steel within the required time period or that they are not producing bars of the required diameter, the Engineer may allow the procurement of steel from other suppliers, provided that the reinforcement is manufactured from billets procured from the original producers. In such cases, the manufacturer’s certificate alone shall notbe considered as sufficient and the steel shall be got tested by the Engineer in the NABL accredited laboratories only, as a third party check. It shall be ensured that all the test resultsconform to IS:1786 requirements.

Only new steel shall be delivered to the site. Every bar shall be inspected before assembling on the work and defective, brittle or burnt bars shall be discarded. Bars with cracked ends shall be discarded.

For the steel procured from original producers also, the Engineer / Employer may carry out occasional checks on materials through third party as mentioned above, for confirming the test results shown in the certificates, in case of any doubt regarding the quality of steel supplied.

1009.3.2 Coating of Reinforcing Bars

1009.3.2.1 Fusion Bonded Epoxy Coated Reinforcement

Fusion bonded epoxy coated reinforcement shall conform to IS:13620 or other international standards as approved by Engineer. The location of the source of supply of the coated bars shall be such as to ensure that the bars are not transported for a distance of more than 300 Km.

Additional requirements for the use of such reinforcement bars are given below:

- a) Patch up materials shall be procured in sealed containers with certificates from the agency who has supplied the fusion bonded epoxy bars.
- b) PVC coated G.I. binding wires of 18G shall only be used in conjunction with fusion bonded epoxy bars.
- c) Chairs for supporting the reinforcement shall also be of fusion bonded epoxy coated bars.
- d) The cut ends and damaged portions shall be touched up with repair patch up material.
- e) The bars shall be cut by saw-cutting and not by flame cutting.
- f) While bending the bars, the pins of work benches shall be provided with PVC or plastic sleeves.
- g) The coated steel shall not be directly exposed to sun rays or rains and shall be protected with opaque polyethylene sheets or such other approved materials.
- h) While concreting, the workmen or trolley shall not move directly on coated bars but shall move only on wooden planks placed on the bars.

1009.3.2.2 Hot Dipped Galvanized Bars

Hot dipped galvanized reinforcing steel shall be provided wherever specified. The coating shall conform to IS:12594-1988.

1009.4 Grey Iron Castings

Grey Iron castings to be used for bearings shall have the following minimum properties:

- | | | |
|-----|-----------------------------------|------------|
| i) | Minimum ultimate tensile strength | 370 MPa |
| ii) | Modulus of Elasticity | 147000 MPa |

iii)	Brinell Hardness	230 MPa
iv)	Shear Strength	370 MPa
v)	Compressive Strength	1370 MPa

The testing shall be as specified in IS:210.

1009.5 Steel Forgings

Forged steel pins shall comply with clause 3, 3A or 4 of IS:1875 and steel forgings shall comply with clause 3, 3A or 4 of IS:2004. Raw materials of the forging shall be as per IS:1875 with minimum reduction ratio of 1.8:1. Alternatively, if forging is made from ingot, the minimum reduction ratio shall be 4:1. Forging shall be normalized.

1009.6 Structural Steel

Unless otherwise permitted, all structural steel shall, before fabrication, comply with the requirements of the following Indian Standards:

IS:226	:	Structural Steel (Standard Quality)
IS:961	:	Structural Steel (High Tensile)
IS:2062	:	Weldable Structural Steel
IS:8500	:	Weldable Structural Steel (medium and high strength qualities)
IS:1148	:	Hot rolled rivet bars (upto 40 mm dia) for structural purposes
IS:1149	:	High tensile rivet bars for structural purposes
IS:1161	:	Steel tubes for structural purposes
IS:4923	:	Hollow Steel sections for structural use
IS:11587	:	Structural weather resistant steel
IS:808	:	Specifications for Rolled Steel Beam, Channel and Angle Sections IS:1239
	:	Mild Steel Tubes
IS:1730	:	Dimension for Steel Plate, sheet and strip for structural and general Engineering purposes.
IS:1731	:	Dimension for Steel flats for structural and general

engineering purposes

IS:1732 : Dimension for round and square steel bars for structural and general engineering purposes.

IS:1852 : Rolling and cutting tolerances for hot rolled steel products

The use of structural steel not covered by the above standards may be permitted with the specific approval of the Engineer. Refer to Section 1900 of these Specifications for further details.

1009.7 Stainless Steel

Stainless steel shall be austenitic chromium-nickel steel, possessing rust, acid and heat resistant properties conforming to IS:6603 and IS:6911. Mechanical properties/grade for such stainless steel shall be as specified by the accepting authority, but in no case inferior to mild steel. Generally, stainless steel is available as per AISI grades. AISI 304 which is equivalent to grade 04 Cr 18 Ni 110 of IS:6911 satisfies the requirements for mechanical properties of structural steel. Other grades of stainless steel for specific purposes may be provided as per specific requirements. For application in adverse/corrosive environment, stainless steel shall conform to AISI 316L or 02G17 Ni Mo2 of IS:6911.

1010 WATER

Water used for mixing and curing shall be clean and free from oils, acids, alkalis, salts, sugar, organic materials or other substances that may be deleterious to concrete or steel.

In case of doubt regarding development of strength, the suitability of water proposed to be used for the production of concrete shall be ascertained by carrying out tests for the compressive strength of concrete and initial setting time of cement using the same water.

The sample of water taken for testing shall represent the water proposed to be used for concreting, taking into account seasonal variations, if any. The sample shall not receive any treatment before testing other than that being given to the regular supply of water proposed for use in concrete. The sample shall be stored in a clean container previously rinsed out with similar water.

Average 28 days compressive strength of at least three 150 mm concrete cubes prepared with water proposed to be used, shall not be less than 90 percent of the average strength of three similar concrete cubes prepared with distilled water. The cubes shall be prepared, cured and tested in accordance with the requirements of IS:516.

The initial setting time of test block made with the appropriate cement and the water proposed to be used shall not be less than 30 minutes and shall not be more than 30 minutes from the initial setting

time of control test block prepared with the same cement and distilled water. The test blocks shall be prepared and tested in accordance with the requirements of IS:4031 (Part 5).

pH value of water shall not be less than 6. Potable water is generally considered satisfactory for mixing concrete. Mixing and curing with sea water shall not be permitted.

As a guide, the following concentrations represent the maximum permissible values:

- a) To neutralize 100 ml sample of water, using phenolphthalein as an indicator, it should not require more than 5 ml of 0.02 normal NaOH. For details of test refer IS:3025(Part 22).
- b) To neutralize 100 ml sample of water, using mixed indicator, it should not require more than 25 ml of 0.02 normal. H₂SO₄. For details of test refer IS: 3025(Part 23).
- c) The Permissible limit's for solids shall be as follows

	Tested as Per	Permissible Limit max
Organic	IS:3025(Pt.18)	200 mg/lit
Inorganic	IS:3025(Pt.18)	3000 mg/lit
Sulphates (SO ₃)	IS:3025(Pt.28)	400 mg/lit
Chlorides (Cl)	IS:3025(Pt.32)	2000 mg/lit for concrete work not containing embedded steel and 500 mg/lit for prestressed/reinforced concrete work
Suspended matter	IS:3025(Pt.17)	2000 mg/lit

All samples of water (including potable water) shall be tested and suitable measures taken, where necessary, to ensure conformity of the water to the requirements stated herein.

1011 TIMBER

The timber used for structural purposes shall conform to IS:883.

1012 CONCRETE ADMIXTURES

1012.1 General

Admixtures may be added to the concrete before or during mixing with a view to modifying one or more of the properties of concrete in the plastic or hardened state.

1012.2 Mineral Admixtures

Any of the following mineral admixtures may be used as part replacement of Portland Cement with the approval of the Engineer.

Fly ash: conforming to of IS:3812-3

Granulated slag: Ground granulated slag obtained by grinding granulated slag conforming to IS:12089.

Silica fume: Silica fume is very fine, non- crystalline SiO_2 , obtained as a by-product of Silicon and Ferro – Silicon alloy industries and shall conform to IS:15388

1012.3 Chemical Admixtures

1012.3.1 Information Required from the Manufacturer

Chemical admixtures are proprietary items of manufacture and shall be obtained only from established manufacturers with proven track record, quality assurance and full fledged laboratory facilities for the manufacture and testing of concrete.

The contractor shall provide the following information concerning each admixture, after obtaining the same from the manufacturer:

- a) Normal dosage and detrimental effects, if any, of under dosage and over dosage.
- b) The chemical names of the main ingredients.
- c) The chloride content, if any, expressed as a percentage by weight of the admixture.
- d) Values of dry material content, ash content and relative density which can be used for Uniformity Tests.
- e) Whether it leads to the entrainment of air when used as per the

manufacturer's recommended dosage, and if so to what extent.

- f) Confirmation regarding its compatibility with type of cement.
- g) Whether it increases the risk of corrosion of reinforcement or other embedments.
- h) Whether it affects the durability of concrete adversely.

1012.3.2 Physical and Chemical Requirements

Admixtures shall conform to the requirements of IS:9103. In addition, the following conditions shall be satisfied.

- a) "Plasticisers" and "Super-Plasticisers" shall meet the requirements indicated for "Water reducing Admixture".
- b) Except where resistance to freezing and thawing and to disruptive action of deicing salts is required, the air content of freshly mixed concrete in accordance with the pressure method given in IS:1199, shall not be more than 2 percent higher than that of the corresponding control mix and in any case not more than 3 percent of the test mix.
- c) The chloride content of the admixtures shall not exceed 0.2 percent when tested in accordance with IS:6925. In addition, the maximum permissible limit of chloride content of all the constituents as indicated in Section 1700 of these Specifications shall also not be exceeded.
- d) Uniformity tests on the admixtures are essential to compare qualitatively the composition of different samples taken from batch to batch or from the same batch at different times.

The tests that shall be performed along with permissible variations are as follows:

- i) Dry Material Content : within 3 percent and 5 percent of liquid and solid
 - ii) Ash content : within 1 percent of the value stated by the manufacturer.
 - iii) Relative Density (for liquid admixtures) : within 2 percent of the value stated by the manufacturer.
- e) All tests relating to concrete admixtures shall be conducted periodically at an independent laboratory and the results compared with the data given by the manufacturer.

1013 REINFORCED AND PRESTRESSED CONCRETE PIPES

Reinforced concrete pipes for highway structures shall be of NP4 type conforming to the requirements of IS:458. Prestressed concrete pipes (NP4) conforming to IS: 784 can also be used depending on the requirement.

1014 STORAGE OF MATERIALS

1014.1 General

All materials shall be stored at proper places so as to prevent their deterioration, intrusion of foreign matter and ensure their satisfactory quality and fitness for the work. The storage space must also permit easy inspection, removal and re-storage of the materials. All such materials, even though stored in approved godowns/places, must be subjected to acceptance test prior to their immediate use.

1014.2 Bricks

Bricks shall not be dumped at site, but shall be stacked in regular tiers as they are unloaded, to minimize breakage and defacement. Bricks selected for use in different situations shall be stacked separately. Sufficient supply of bricks as required for the works, shall be available at site at any time.

1014.3 Aggregates

Aggregate stockpiles may be made on ground that is hard, well drained and devoid of vegetation.

Coarse aggregates, unless otherwise agreed by the Engineer in writing, shall be delivered to the site in separate sizes (2 sizes when nominal size is 25 mm or less and 3 sizes when the nominal size is 32 mm or more). In case of aggregates placed directly on the ground the material in the stock pile only up to a level of 30 cm above the ground level shall be taken out and used initially. Remaining material shall be permitted to be used in the final stages of work only after it has been fully cleaned.

1014.4 Cement

Cement shall be transported, handled and stored on the site in such a manner as to avoid deterioration or contamination. Cement shall be stored above ground level in perfectly dry and water-tight sheds and shall be stacked to a height of not more than eight bags. Wherever bulk storage containers are used, their capacity should be sufficient to cater to the requirement at site. The containers shall be cleaned at least once every 3 months.

Cement shall be used in the sequence in which it is delivered at site. Each consignment shall be stored separately so that it may be readily identified and inspected. Any consignment or part of a consignment of cement which has deteriorated in any way during storage, shall not be used in the works and shall be removed from the site by the Contractor at his own cost.

The Contractor shall prepare and maintain proper records at site in respect of delivery, handling, storage and use of cement and these records shall be available for inspection by the Engineer at all times.

The Contractor shall submit a monthly return to the Engineer showing the quantities of cement received and issued during the month and in stock at the end of the month.

1014.5 Reinforcement/Untensioned Steel

The reinforcement bars, shall be stored above the surface of the ground upon platforms, skids or other supports, and shall be protected from mechanical injury and from deterioration by exposure.

1014.6 Prestressing Materials

All prestressing steel, sheathing, anchorages and sleeves or couplers shall be protected during transportation, handling and storage. The prestressing steel, sheathing and other accessories shall be stored under cover from rain or damp ground and protected from the ambient atmosphere if it is likely to be aggressive. Period of storage at site must be kept to the absolute minimum.

- a) **Tendons** : Wires, strands and bars from which tendons are to be fabricated shall be stored about 300 mm above the ground in a suitably covered and closed space so as to avoid direct climatic influences and to protect them from splashes from any other materials and from the cutting operation of an oxy-acetylene torch or arc welding process in the vicinity. Under no circumstances shall tendon material be subjected to any welding operation or on site heat treatment or metallic coating such as galvanizing. Storage facilities and the procedures for transporting material into or out of the store, shall be such that the material does not become kinked or notched. Wires or strands shall be stored in large diameter coils which enable the tendons to be laid out straight. As a guide, for wires above 5 mm dia, coils of about 3 m dia without breaks or joints shall be obtained from manufacturer. Protective wrapping for tendons shall be chemically neutral. All prestressing steel must be provided with temporary protection during storage.
- b) **Anchorage Components** : The handling and storing procedures shall maintain the anchorage components in a condition in which they can subsequently perform their function to an adequate degree. Components shall be handled and stored so that mechanical damage and detrimental corrosion are prevented. The corrosion of the gripping and securing

system shall be prevented. The use of correctly formulated oils and greases or of other corrosion preventing material, shall be guaranteed by the producer to be non-aggressive and non-degrading.

Prestressing steel which shall be absolutely clean and without any signs of rust, shall be stored in a closed store having single door with double locking arrangements and no windows. The air inside the store shall be kept dry as far as possible by using various means to the satisfaction of the Engineer, so as to eliminate the possibility of initial rusting of prestressing steel during storage. Instrument measuring the air humidity shall be installed inside the store. The prestressing steel shall be coated with water-soluble grease.

All prestressing steel shall be stored at least 300 mm above ground level and shall be invariably wrapped with a protective covering of tar paper or polythene or any other approved material.

The Contractor should ensure that prestressing steel is used within 3 months of its manufacture. He should chalk out his prestressing programme in such a manner as to avoid the possibility of initial corrosion before placing in position.

1014.7 Water

Water shall be stored in containers/tanks covered at top and cleaned at regular intervals in order to prevent intrusion of foreign matter or growth of organic matter. Use of water from shallow, muddy or marshy sources, shall not be permitted. The intake pipe shall be suitably enclosed to exclude silt, mud, grass and other solid materials and there shall be a minimum depth of 0.60 m of water below the intake at all times.

1015 TESTS AND STANDARD OF ACCEPTANCE

All materials, even though stored in an approved manner shall be subjected to an acceptance test in accordance with the relevant IS specification prior to their immediate use.

Independent testing of cement for every consignment shall be done by the Contractor at site or in the laboratory approved by the Engineer before use. Any cement with lower quality than that shown in manufacturer's certificate shall be debarred from use. In case of imported cement, the same series of tests shall be carried out before acceptance.

1015.1 Testing and Approval of Material

The Contractor shall furnish test certificates from the manufacturer/supplier of materials along with each batch of material(s) delivered to site.

The Contractor shall set up a field laboratory with necessary equipment for testing of all materials, finished products used in the construction as per requirements of conditions of contract and the relevant specifications. The testing of all the materials shall be carried out by the Engineer for which the shall make all the necessary arrangements and bear the entire cost.

Test which cannot be carried out in the field laboratory have to be got done at the Contractor's cost at any recognized laboratory/testing establishments approved by the Engineer.

1015.2 Sampling of Materials

Samples provided to the Engineer for inspection are to be in labelled boxes suitable for storage.

Samples required for testing and approval must be supplied well in advance by at least 48 hours or before the minimum period required for carrying out the relevant tests. Delay to works arising from the late submission of samples, will not be acceptable as a reason for delay in completion of the works.

If materials are brought from abroad, the cost of sampling/testing whether in India or abroad shall be borne by the Contractor.

1015.3 Rejection of Materials not Conforming to the Specifications.

Any stack or batch of material(s) of which sample(s) does (do) not conform to the prescribed tests and quality shall be rejected by the Engineer and such materials shall be removed from site by the Contractor at his own cost. Such rejected materials shall not be made acceptable by any rectifications.

1015.4 Testing and Approval of Plant and Equipment

All plants and equipment used for preparing, testing and production of materials for incorporation into the permanent works, shall be in accordance with manufacturer's specifications and shall be got approved by the Engineer before use.

1300

Brick Masonry

1301 Description

This work shall consist of construction of structures with bricks jointed together by cement mortar, in accordance with the details shown on the drawings or as approved by the Engineer.

1302 Materials

All materials to be used in the work shall conform to the requirements laid down in **section 1000** of these specifications.

1303 Personnel

Construction of brick work shall be carried out only by masons having sufficient experience/training in the work.

1304 Cement Mortar

1304.1 Proportioning and Mixing of Mortar

Cement and sand shall be mixed in specified proportions given on the drawings. Cement shall be proportioned by weight, taking the unit weight of cement as 1.44 tonne per cubic metre. Sand shall be proportioned by volume with due allowance for bulking. All mortar shall be mixed with a minimum quantity of water to produce desired workability consistent with required density. The mix shall be clean and free from soil, acid, alkali, organic matter or other deleterious substances.

The mixing shall be done in a mechanical mixer operated manually or by power. As an exception, hand mixing can also be resorted to as long as uniform density of the mix and its strength are assured. Hand mixing shall be permitted only for very small and isolated works like CD works, subject to the prior approval of the Engineer. Hand mixing shall be carried out on a clean watertight platform, where cement and sand shall be first mixed dry in the required proportion by being turned over and over, backwards and forwards, several times till the mixture is of uniform colour. Thereafter, minimum quantity of water shall be added to bring the mortar to the consistency of a stiff paste. The mortar shall be mixed for at least two minutes after addition of water.

Mortar shall be mixed only in such quantity as required for immediate use. The mix which has developed initial set shall not be used. Initial set of mortar with ordinary Portland Cement shall normally be considered to have taken place in 30 minutes after mixing. In case the mortar has stiffened during initial setting time because of evaporation of water, it can be re-tempered by adding water as frequently as needed to restore the requisite consistency, but such re-tempering shall not be

permitted 30 minutes after mixing. Mortar remaining unused for more than 30 minutes after mixing, shall be rejected and removed from site of work.

1304.2 testing of Mortar

Necessary tests to determine compressive strength of the mortar, its consistency and waterresistivity shall be carried out in accordance with IS:2250. For compressive strength tests, the frequency of testing shall be 1 cube for every 2 cu.m of mortar, subject to a minimum of 3 cubes for a day's work.

1305 Soaking Of Bricks

All bricks shall be thoroughly soaked in a tank filled with water for a minimum period of one hour prior to being laid. Soaked bricks shall be removed from the tank sufficiently in advance so that they are skin dry at the time of actual laying. Such soaked bricks shall be stacked at a clean place where they are not contaminated with dirt, earth, etc.

1306 Joints

The thickness of joints shall not exceed 10 mm. All joints on exposed faces shall be tooled to give concave finish.

1307 Laying

All brickwork shall be laid in an English bond, even and true to line, plumb and level and all joints accurately kept in accordance with the drawing or as directed by the Engineer. Half and cut bricks shall not be used except when necessary to complete the bond. Closer in such cases shall be cut to the required size and used near the ends of the walls. The bricks used at the face and also at all angles forming the junction of any two walls shall be selected whole bricks of uniform size, with true and rectangular faces.

All bricks shall be laid with frogs up on a full bed of mortar except in the case of tile bricks. Each brick shall be properly bedded and set in position by slightly pressing while laying, so that the mortar gets into all its surface pores to ensure proper adhesion. All head and side joints shall be completely filled by applying sufficient mortar to brick already placed and on brick to be placed. All joints shall be properly flushed and packed with mortar so that no hollow spaces are left. No bats or cut bricks shall be used except to obtain dimensions of the different courses for specified bonds or wherever a desired shape so requires.

The brick work shall be built in uniform layers and for this purpose, wooden straight edge with graduations indicating thickness of each course including joint shall be used. Corners and other advanced work shall be raked back. Brickwork shall be done true to plumb or in specified batter. All courses shall be laid truly horizontal, and vertical joints shall be truly vertical. Vertical joints in alternate courses shall come directly one over the other. During construction, no part of work shall rise more than one metre above the general construction level, to avoid unequal settlement and

improper jointing. Where this is not possible, the work shall be raked back according to the bond (and not toothed) at an angle not steeper than 45 degree with prior approval of the Engineer. Tothing may also be permitted where future extension is contemplated.

Before laying bricks in foundation, the foundation slab shall be thoroughly hacked, swept clean and wetted. A layer of mortar not less than 12 mm thick shall be spread on the surface of the foundation slab before the first course of bricks is laid.

1308 Jointing Old And New Work

Where fresh masonry is to join with masonry that is partially/entirely set, the exposed jointing surface of the set masonry shall be cleaned, roughened and wetted, so as to achieve the best possible bond with the new work. All loose bricks and mortar or other material shall be removed.

In the case of vertical or inclined joints, it shall be further ensured that proper bond between the old and new masonry is obtained by interlocking the bricks. Any portion of the brickwork that has been completed, shall remain undisturbed until thoroughly set.

In case of sharp corners specially in skew bridges, a flat cutback of 100 mm shall be provided so as to have proper and bonded laying of bricks.

1309 CuRinG

Green work shall be protected from rain by suitable covering and shall be kept constantly moist on all faces for a minimum period of seven days. Brick work carried out during the day shall be suitably marked indicating the date on which the work was done, so as to keep a watch on the curing period. The top of the masonry work shall be left flooded with water at the close of the day. Watering shall be done carefully so as not to disturb or wash out the green mortar.

During hot weather, all finished or partly completed work shall be covered or wetted in such a manner as to prevent rapid drying of the brickwork.

During the period of curing, the brick work shall be suitably protected from all damages. At the close of day's work or for other period of cessation, watering and curing shall have to be maintained. Should the mortar perish i.e. become dry, white or powdery through neglect of curing, work shall be pulled down to the extent required and rebuilt as directed by the Engineer. If any stains appear during watering, the same shall be removed from the surface.

1310 Scaffolding

The scaffolding shall be sound, strong and safe to withstand all loads likely to come upon it. The holes which provide resting space for horizontal members shall not be left in masonry under one metre in width or immediately near the skew backs of arches. The holes left in the masonry work for supporting the scaffolding shall be filled and made good. Scaffolding shall be got approved by the Engineer, but its safety shall be the responsibility of the Contractor.

1311 Equipment

All tools and equipment used for mixing, transporting and laying of mortar and bricks shall be clean and free from set mortar, dirt or other injurious foreign substances.

1312 Finishing Of Surfaces

1312.1 General

All brickwork shall be finished in a workmanlike manner with the thickness of joints, manner of striking or tooling as described in these specifications.

The surfaces can be finished by jointing, pointing or plastering, as shown on the drawings.

For a surface which is to be subsequently plastered or pointed, the joints shall be squarely raked out to a depth of 15 mm, while the mortar is still green. The raked joints shall be well brushed to remove dust and loose particles and the surface shall be thoroughly cleaned and wetted.

The mortar for finishing shall be prepared as per Clause 1304.

1312.2 Jointing

In jointing, the face of the mortar shall be worked out while still green to give a finished surface flush with the face of the brick work. The faces of brick work shall be cleaned to remove any splashes of mortar during the course of raising the brick work.

1312.3 Pointing

Pointing shall be carried out using mortar not leaner than 1:3 by volume of cement and sand or as shown on the drawing. The mortar shall be filled and pressed into the raked joints before giving the required finish. The pointing shall be ruled type for which it shall, while still green, be ruled along the centre with half round tools of such width as may be specified by the Engineer. The superfluous mortar shall then be taken off from the edges of the lines and the surface of the masonry shall be

cleaned of all mortar. The work shall conform to IS:2212. Raised pointing which projects beyond the face of stone, brick or block shall be avoided.

1312.4 Plastering

Plastering shall be done where shown on the drawing. Superficial plastering may be done, if necessary, only in structures situated in fast flowing rivers or in severely aggressive environment.

Plastering shall be started from top and worked down. All holes shall be properly filled in advance of the plastering, while the scaffolding is being taken down. Wooden screeds 75 mm wide and of the thickness of the plaster shall be fixed vertically 2.5 m to 4 m apart,

to act as gauges and guides in applying the plaster. The mortar shall be laid on the wall between the screeds using the plasterer's float and pressing the mortar so that the raked joints are properly filled. The plaster shall then be finished off with a wooden straight edge reaching across the screeds. The straight edge shall be worked on the screeds with a small upward and sideways motion 50 mm to 75 mm at a time. Finally, the surface shall be finished off with a plasterer's wooden float. Metal floats shall not be used.

When re-commencing plastering beyond the work suspended earlier, the edges of the old plaster shall be scraped, cleaned and wetted before plaster is applied to the adjacent areas.

No portion of the surface shall be left unfinished for patching up at a later period.

The plaster shall be finished true to plumb surface and to the proper degree of smoothness as directed by the Engineer.

The average thickness of plaster shall not be less than that specified. The minimum thickness over any portion of the surface shall not be less than the specified thickness by more than 3 mm.

Any cracks which appear in the surface and all portions which sound hollow when tapped, or are found to be soft or otherwise defective, shall be cut in rectangular shape and re-done as directed by the Engineer.

1312.5 Curing of Finishes

Curing shall be commenced as soon as the mortar used for finishing has hardened sufficiently so as not to be damaged during curing. The curing shall be done for a period of at least 7 days, during which the finishing shall be suitably protected from all damages.

1312.6 scaffolding for Finishes

Stage scaffolding independent of the structure, shall be provided for the work of finishing.

1313 Coping For Wing/Return/Parapet Wall

This work shall consist of providing an architectural coping for wing/return/parapet walls.

The material used shall be cement mortar 1:3 or as shown on the drawings prepared in accordance with Clause 1304.

The cement mortar shall be laid evenly to an average thickness of 15 mm to the full width of the top of the wall and in a band of 150 mm depth along the top outer face of the walls.

1314 Acceptance Of Work

All work shall be true to lines and levels as indicated on the drawing or as directed by the Engineer, subject to tolerances as indicated in these specifications.

Mortar cubes shall be tested in accordance with IS:2250 for compressive strength, consistency of mortar and its water retentivity. The frequency of testing shall be one sample for every 2 cubic metres of mortar subject to a minimum 3 samples for a day's work.

In case of plaster finish, the minimum surface thickness shall not be less than the specified thickness by more than 3 mm.

1315 Measurements For Payment

1315.1 All brick work shall be measured in cubic metres. Any extra work done by the Contractor in excess of the specified dimensions, shall be ignored.

1315.2 In arches, the length of arch shall be measured as the average of the lengths along the extrados and the intrados.

1315.3 The work of plastering and pointing shall be measured in square metres of the surface treated.

1315.4 Coping shall be measured in linear metres.

1316 Rate

1316.1 The contract unit rate for brick work shall include the cost of all labour, materials, tools and plant, scaffolding and other expenses incidental to the satisfactory completion of the work, sampling, testing and supervision as described in these specifications and as shown on the drawings.

1316.2 The contract unit rate for plastering shall include the cost of all labour, materials, tools and plant, scaffolding and all incidental expenses, sampling, testing and supervision, as described in these specifications.

1316.3 The contract unit rate for pointing shall include erecting and removal of scaffolding, all labour, materials, and equipment incidental to completing the pointing, raking out joints, cleaning, wetting, filling with mortar, trowelling, pointing and watering, sampling and testing and supervision as described in these specifications.

1316.4 The contract unit rate for coping shall include cost of all labour, materials, tools and plant, sampling and testing and supervision as described in these specifications.

1400

**Stone And Concrete
Block Masonry**

1401 Description

This work shall consist of construction of structures with stones or concrete blocks jointed together by cement mortar in accordance with the details shown on the drawings and these specifications or as approved by the Engineer.

1402 Materials

All materials to be used in stone and concrete block masonry, shall conform to Section 1000 of these Specifications, except cement mortar which shall conform to Clause 1304 of these Specifications.

1403 Personnel

Only trained personnel shall be employed for construction and supervision.

1404 Type Of Masonry

The type of masonry used for structures shall be random rubble (coursed or uncoursed) or coursed rubble (first sort) or concrete block. For bridge work generally, coursed rubble masonry shall be used. The actual type of masonry used for different parts of structures shall be specified on the drawings. For facing work, ashlar masonry shall be used where indicated on the drawings.

1405 Construction

1405.1 stone Masonry

1405.1.1 General

The dressing of stone shall be as specified for individual type masonry work and it shall also conform to the general requirements of IS:1597 and requirement for dressing of stone covered in IS:1129. Other specific requirements are covered separately with respect to particular types of rubble stone work.

1405.1.2 Laying

1405.1.2.1 The masonry work shall be laid to lines, levels, curves and shapes as shown on the drawing. The height in each course shall be kept same and every stone shall be finetooled on all beds, joints and faces, full and true. The exposed faces shall be gouged out, grooved, regulated and sunk or plain moulded as the case may be. The faces of each stone between the draft shall be left rough as the stone comes from the quarry, except where sacrificial layer is to be provided or plastering is resorted to in aggressive environment.

1405.1.2.2 Stones shall be sufficiently wetted before laying to prevent absorption of water from mortar.

Stratified stones shall be laid on their natural beds. All bed joints shall be normal to the direction of pressure coming on them.

Stones in the hearting shall be laid on their broadest faces so as to give better facility to fill the spaces between them.

The courses of the masonry shall ordinarily be pre-determined. They shall generally be of the same height. When there is to be variation in the height of courses, the larger courses are to be placed at lower levels, heights of courses decreasing gradually towards the top of the wall. The height of course shall not be less than 160 mm. placing loose mortar on the course and pouring water on it to fill the gaps in stones is not acceptable. Mortar shall be mixed thoroughly and poured in the joints in fluid state. No dry or hollow space shall be left anywhere in the masonry and each stone shall have all the embedded faces completely covered with mortar.

In tapered walls, the beds of the stones and the planes of course should be at right angles to the batter. In case of bridge piers with batter on both sides, the course shall be horizontal.

The bed which is to receive the stone, shall be cleaned, wetted and covered with a layer of fresh mortar. All stones shall be laid full in mortar both in bed and vertical joints and settled carefully in place with a wooden mallet immediately on placement and solidly embedded in mortar before it has set. Clean chips and spalls shall be wedged into the mortar joints and bed wherever necessary to avoid thick beds or joints of mortar. When the foundation masonry is laid directly on rock, the face stones of the first course shall be dressed to fit into rock snugly, when pressed down in the mortar bedding over the rock. No dry or hollow space shall be left anywhere in the masonry and each stone shall have all the embedded faces completely covered with mortar. For masonry works over rock, a levelling course of 150 mm thick M15 concrete, shall be laid over rock and then stone masonry work shall be laid without foundation concrete block.

Face works and hearting shall be brought up evenly but the top of each course shall not be levelled by the use of flat chips.

For sharp corners specially in skew bridges, through stones shall be used in order to avoid spalling of corners.

In case any stone already set in mortar, is disturbed or the joints broken, it shall be taken out without disturbing the adjoining stones and joints. Dry mortar shall be thoroughly cleaned from the joints and stones and the stones reset in fresh mortar. When freshly laid, no attempt shall be made to slide one stone on top of another.

Shaping and dressing shall be done before the stone is laid in the work. No dressing or hammering, which will loosen the masonry, will be allowed after the stone is placed in position. All necessary chases for joggles, dowels and clamps, should be formed beforehand.

Sufficient transverse bonds shall be provided by the use of bond stone extending from the front to the back of the wall and in case of thick wall, from outside to the interior and vice versa. In the latter case, bond stones shall overlap each other in their arrangement.

In case headers are not available, precast headers of M15 concrete shall be used. Cast in-situ headers are not permitted.

Stones shall break joint on the face for at least half the height of the course and the bond shall be carefully maintained throughout.

In band work at all angle junctions of walls, the stones at each alternate course shall be carried into each of the respective walls so as to unite the work thoroughly.

Building up thin faces tied with occasional through stones and filling up the middle with small broken stones or even dry packing, is not acceptable.

All quoins and the angles of the opening shall be made from selected stones, carefully squared and bedded and arranged to bond alternately long and short in both directions.

All vertical joints shall be truly vertical. Vertical joints shall be staggered as far as possible. Distance between the vertical joints of upper layer and lower layer, shall not be less than half the height of the course.

Only rectangular shaped bond stones or headers shall be used. Bond stones shall overlap each other by 150 mm or more.

All connected masonry in a structure shall be carried up nearly at one uniform level throughout but when breaks are unavoidable, the masonry shall be raked in sufficiently long steps to facilitate jointing of old and new work. The stepping of raking shall not be more than 45 degree with the horizontal.

1405.1.3 Random Rubble Masonry (uncoursed and Coursed) 1405.1.3.1 dressing

The stone shall be hammer dressed on the face, the sides and beds to enable it to come in proximity with the neighbouring stone. The bushing on the exposed face shall not be more than 40 mm.

1405.1.3.2 insertion of Chips

Chips and spalls of stone may be used wherever necessary to avoid thick mortar beds or joints and it shall be ensured that no hollow spaces are left anywhere in the masonry. The chips shall not be used below hearting stones to bring these up to the level of face stones. Use of chips shall be restricted to filling of interstices between the adjacent stones in hearting and they shall not exceed 20 percent of the quantity of stone masonry.

1405.1.3.3 Hearting stones

The hearting or interior filling of the wall face shall consist of rubble stones not less than 150mm long in any direction, carefully laid, hammered down with a wooden mallet into position and solidly bedded in mortar. The hearting should be laid nearly level with facing and backing.

1405.1.3.4 Bond stones

Through bond stones shall be provided in masonry up to 600 mm thickness and in case

of masonry above 600 mm thickness, a set of two or more bond stones overlapping each other at least by 150 mm shall be provided in a line from face to back. In case of highly absorbent types of stones (porous limestone and sandstones, etc.,) the bond stone shall extend only about two-thirds into the wall, as through stones in such cases may give rise to penetration of dampness and therefore, for all thicknesses of such masonry, a set of two or more bond stones overlapping each other by at least 150 mm shall be provided. One bond stone or a set of bond stones shall be provided for ever

0.50 sq.m of the masonry surface.

1405.1.3.5 Quoin stone

Quoin stone specially selected and neatly dressed for forming an external angle in masonry work, shall not be less than 0.03 Cu.m in volume.

1405.1.3.6 Plum stone

The plum stones are selected long stones embedded vertically in the interior of the masonry to form a bond between successive courses and shall be provided at about 900 mm intervals.

1405.1.3.7 Laying

The masonry shall be laid with or without courses as specified. The quoins shall be laid header and stretcher alternately. Every stone shall be fitted to the adjacent stone so as to form neat and close joint. Face stone shall extend and bond well in the back. These shall be arranged to break joints, as much as possible, and to avoid long vertical lines of joints.

1405.1.3.8 Joints

The face joints shall not be more than 20 mm thick, but shall be sufficiently thick to prevent stone-to-stone contact and shall be completely filled with mortar.

1405.1.4 Coursed Rubble Masonry (First sort) 1405.1.4.1 dressing

Face stone shall be hammer dressed on all beds and joints so as to give them rectangular shape. These shall be square on all joints and beds. The bed joints shall be chisel drafted for at least 80 mm back from the face and for at least 40 mm for the side joints. No portion of the dressed surface shall show a depth of gap more than 6 mm from the straight edge placed on it. The remaining unexposed portion of the stone shall not project beyond the surface of bed and side joints. The requirements regarding bushing shall be the same as for random rubble masonry.

1405.1.4.2 Hearting stones

The hearting or interior filling of the wall face shall consist of flat bedded stone carefully laid, on prepared beds in mortar. The use of chips shall be restricted to the filling of interstices between the adjacent stones in hearting and these shall not exceed 10 percent of the quantity

of masonry. While using chips it shall be ensured that no hollow spaces are left anywhere in the masonry.

1405.1.4.3 Bond stones

The requirements regarding through or bond stone shall be the same as for random rubble masonry, but these, shall be provided at 1.5 to 1.8 metre apart clear in every course.

1405.1.4.4 Quoin stone

The quoins shall be of the same height as the course in which they occur and shall be formed of header stones not less than 450 mm in length. They shall be laid lengthwise alternately along each face, square in their beds which shall be fairly dressed to a depth of at least 100 mm.

1405.1.4.5 Face stone

Face stones shall tail into the work for not less than their heights and at least one-third of the stones shall tail into the work for a length not less than twice their height. These shall be laid as headers and stretchers alternately.

1405.1.4.6 Laying

The stones shall be laid on horizontal courses and all vertical joints should be truly vertical. The quoin stones should be laid header and stretcher alternately and shall be laid square on their beds, which shall be rough chisel dressed to a depth of at least 100 mm.

1405.1.4.7 Joints

The face joints shall not be more than 10 mm thick, but shall be sufficiently thick to prevent stone-to-stone contact and shall be completely filled with mortar.

1405.1.5 ashlar Masonry (Plain ashlar)

1405.1.5.1 dressing

Every stone shall be cut to the required size and shape, chisel dressed on all beds and joints, so as to be free from all bushing. Dressed surface shall not show a depth of gap of more than 3 mm from straight edge placed on it. The exposed faces and joints, 6 mm from the face shall be fine tooled so that a straight edge can be laid along the face of the stone in contact with every point. All visible angles and edges shall be true and square and free from chippings. The corner stones (quoins) shall be dressed square and corner shall be straight and vertical.

1405.1.5.2 Bond stones

Through bond stones shall be provided for masonry up to 600 mm thickness and for masonry above 600 mm thickness, a set of two or more bond stones overlapping each other at least by 150 mm, shall be provided in a line from face to back. In case of highly absorbent types of stones (porous limestone and sandstones, etc.,) the bond stone shall extend only about two-thirds into the wall, as through stones in such cases may give rise to penetration of dampness. For masonry with such stones, a set of two or more bond stones overlapping each other by at least 150 mm shall be provided. One bond stone or a set of bond stones shall be 1.5 to 1.8 metre apart clear in every course.

1405.1.5.3 Laying

The face stone shall be laid header and stretcher alternately, the header being arranged to come as nearly as possible in the middle of stretchers above and below. Stones shall be laid in regular courses not less than 300 mm in height and all courses of the same height, unless otherwise specified. No stone shall be less in width than its height or less in length than twice its height, unless otherwise specified.

1405.1.5.4 Joints

All joints shall be full of mortar. These shall not be less than 3 mm thick. Face joints shall be uniform throughout, and a uniform recess of 20 mm depth from face shall be left with the help of a stone plate during the progress of work.

1405.2 Concrete Block Masonry

1405.2.1 Laying

The bed, which is to receive the block, shall be cleaned, wetted and covered with a layer of fresh mortar. The masonry works shall be laid to lines, levels, curves and shapes as shown on the drawing. In battered sections, the beds of blocks and the plane of courses shall be horizontal. Face blocks for such sections shall be manufactured specially for the purpose.

The block shall be soaked in water for at least 15 minutes before laying, to prevent absorption of water from mortar.

Concrete block masonry shall be constructed generally like fine tooled ashlar masonry. Each block must be fitted into its place dry in order that discrepancy of figure may be discovered and corrected before it is finally laid in mortar and settled in bed. The block shall be laid full in thin mortar, the bed and side joints being not more than 15 mm in thickness. Each block shall be struck with a wooden mallet when laid in place in mortar to bring it to solid bearing as to bed and joints. All visible edges shall be free from chippings.

The course shall be horizontal and side joints vertical throughout unless otherwise indicated in plans. Joints shall be struck.

For bond, face blocks shall be laid header and stretcher alternately unless otherwise ordered by the Engineer, the header being arranged to come as nearly as possible in the middle of stretchers below. The blocks in the courses above and below shall break joints for about half the height of the course and bond shall be carefully maintained throughout section.

While carrying out masonry work, templates prepared to the correct shape and approved by the Engineer, shall be used to ensure correct batter as well as correct shape of masonry, specially cut and ease water in piers. The finished work shall be checked at every stage by the competent authority to ensure that it has the correct shape and batter as required by design.

In case of skew bridges and for cut and ease water, the acute angle at the corners shall not be less than 45 degree. In case a smaller angle cannot be avoided, then a flat face of 100 mm shall be provided.

1406 Pointing

Pointing shall be carried out using mortar not leaner than 1:3 by volume of cement and sand or as shown on the drawing. The mortar shall be filled and pressed into the raked out joints before giving the required finish. The pointing shall conform to Clause 1312.3 of this specification. The work shall conform to IS:2212. The thickness of joints shall not be less than 3 mm for ashlar masonry. However, the maximum thickness of joints in different works shall be as follows:

Random Rubble	:	20 mm
Coursed Rubble	:	15 mm
Ashlar Masonry	:	5 mm

1407 Curing

Curing shall conform to Clauses 1309 and 1312.5 of these Specifications.

1408 Scaffolding

For scaffolding, Clause 1310 of these Specifications, shall apply.

1409 weep Holes

Weep holes shall conform to Clauses 2706 of these Specifications.

1410 jointing with existing structures

For jointing with existing structures, the specifications as given for brick masonry under Clause 1308 of these Specifications, shall apply for stone masonry also.

1411 coping for wing/return/parapet Walls

Coping for wing/return/parapet walls shall conform to Clause 1313 of these Specifications.

1412 tests and standards of acceptance

All work shall be done to the lines and levels as indicated on the drawing or as directed by the Engineer, subject to tolerances as specified in these specifications.

Mortar cubes shall be taken in accordance with IS:2250 for testing of compressive strength, consistency and water retentivity. The frequency of testing shall be one sample for every two cubic metres of mortar subject to a minimum of 3 samples for a day's work.

1413 Measurements for payment

1413.1 Stone masonry shall be measured in cubic metres.

1413.2 In arches, the length of arch shall be measured as the average of the lengths along the extrados and the intrados

1413.3 The work of pointing shall be measured in square metres.

1413.4 Architectural coping shall be measured in linear metres.

1414 Rate

1414.1 The contract unit rate for stone masonry shall include the cost of all labour, materials, tools and plant, scaffolding, sampling and testing, supervision and other expenses incidental to the satisfactory completion of the work as described in these Specifications.

1414.2 The contract unit rate for pointing shall include erecting and removal of scaffolding, all labour, materials and equipment incidental to completing the pointing, raking out joints, cleaning, wetting, filling with mortar, trowelling, pointing and watering, sampling and testing and supervision as described in these specifications.

1414.3 The contract unit rate for coping shall include the cost of all labour, materials, tools and plant, sampling and testing and supervision as described in these specifications.

1500

Form work

1501 Description

Formwork shall include all temporary or permanent forms required for forming the concrete of the shape, dimensions and surface finish, as shown on the drawing or as directed by the Engineer, together with all props, staging, centering, scaffolding and temporary construction required for their support.

1502 Materials

All materials shall comply with the requirements of IRC:87. Materials and components used for formwork shall be examined for damage or excessive deterioration before use/re-use and shall be used only if found suitable after necessary repairs. In case of timber formwork, the inspection shall not only cover physical damages but also signs of attacks by decay, rot or insect attack or the development of splits.

Forms shall be constructed with metal or timber. The metal used for forms shall be of such thickness that the forms remain true to shape. All bolts should be countersunk. The use of approved internal steel ties or steel or plastic spacers shall be permitted. Structural steel tubes used as support for forms shall have a minimum wall thickness of 4 mm. Other materials conforming to the requirements of IRC:87 may also be used if approved by the Engineer.

1503 Design Of Formwork

1503.1 The design, erection and removal of formwork shall conform to IRC:87 “Guidelines for Formwork, Falsework and Temporary Structures” and these specifications. The forms shall be such as to ensure that they can be conveniently removed without disturbing the concrete. The design shall facilitate proper and safe access to all parts of formwork for inspection.

1503.2 The Contractor shall furnish the design and drawing of complete formwork (i.e. the forms as well as their supports) for approval of the Engineer before any erection is taken up. If proprietary system of formwork is used, the Contractor shall furnish detailed information as per Appendix 1500/I, to the Engineer for approval.

Notwithstanding any approval or review of drawing and design by the Engineer, the Contractor shall be entirely responsible for the adequacy and safety of formwork.

1503.3 In the case of prestressed concrete superstructure, careful consideration shall be given to redistribution of loads on props due to prestressing.

1504 Workmanship

1504.1 The formwork shall be robust and strong and the joints shall be leak-proof.

Ballies shall not be used as staging. Staging must have cross bracings and diagonal bracings in both directions. Staging shall be provided with an appropriately designed base plate resting on firm strata.

1504.2 The number of joints in the formwork shall be kept to a minimum by using large sized panels. The design shall provide for proper “soldiers” to facilitate alignment. All joints shall be leak proof and must be properly sealed. Use of PVC joint sealing tapes, foam rubber or PVC T-section, is essential to prevent leakage of grout.

1504.3 As far as practicable, clamps shall be used to hold the forms together. Where use of nails is unavoidable, minimum number of nails shall be used and these shall be of the double-headed type. Alternatively, if the nails are of the normal type, they shall be left partially projecting without being driven to their full length, so that they can be withdrawn easily.

1504.4 Use of ties shall be restricted, as far as practicable. Wherever ties are used they shall be used with HDPE sheathing so that they can easily be removed. No parts prone to corrosion shall be left projecting or near the surface. The sheathing shall be grouted with cement mortar of the same strength as that of the structure.

1504.5 Unless otherwise specified, or directed, chamfers or fillets of size 25 mm x 25 mm shall be provided at all angles of the formwork to avoid sharp corners. The chamfers, beveled edges and mouldings shall be made in the formwork itself. Opening for fixtures and other fittings shall be provided in the shuttering as directed by the Engineer.

1504.6 Shuttering for walls, sloping members and thin sections of considerable height shall be provided with temporary openings to permit inspection and cleaning out before placing of concrete.

1504.7 The formwork shall be constructed with pre-camber to the soffit to allow for deflection of the formwork. This shall be in addition to the pre-camber for the permanent structure as shown on the drawings.

1504.8 Where centering trusses or launching trusses are adopted for casting of superstructure, the joints of the centering trusses, whether welded, riveted or bolted shall be thoroughly checked periodically. Also, various members of the centering trusses should be periodically examined for proper alignment and unintended deformation before proceeding with the concreting. They shall also be periodically checked for any deterioration in quality due to steel corrosion. Launching truss, casting truss of span more than 40 m and travelling forms, shall be load tested before they are put to use.

1504.9 The formwork shall be so made as to produce a finished concrete true to shape, line and levels and dimensions as shown on the drawings, subject to the tolerances specified in respective Sections of these specifications, or as directed by the Engineer.

1504.10 Where metal forms are used, all bolts and rivets shall be countersunk and well ground to provide a smooth, plane surface. Where timber is used it shall be well seasoned, free from loose knots, projecting nails, splits or other defects that may mar the surface of concrete.

1504.11 Forms shall be made sufficiently rigid by the use of ties and bracings to prevent any displacement or sagging between supports. They shall be strong enough to withstand all pressure, ramming and vibration during and after placing the concrete. Screw

jacks or hard wood wedges where required shall be provided to make up any settlement in the formwork either before or during the placing of concrete.

1504.12 The formwork shall ensure the correct final shape of the structure, with the calculated amount of positive or negative camber. The deformation of falsework, scaffolding or propping and the instantaneous or deferred deformation due to various causes arising in prestressed structures, shall be properly accounted for.

1504.13 Suitable camber shall be provided to horizontal members of structure, specially in long spans, to counteract the effects of deflection. The formwork shall be so fixed as to provide for such camber.

1504.14 The formwork shall be coated with an approved release agent that will effectively prevent sticking and will not stain the concrete surface. Lubricating oils (machine oils) shall be prohibited for use as coating.

1505 Lining Of Formwork

The formwork shall be lined with material approved by the Engineer so as to provide a smooth finish of uniform texture and appearance. This material shall leave no stain on the concrete and shall be so fixed to its backing as not to impart any blemishes. It shall be of the same type and obtained from only one source throughout for the construction of any one structure. The contractor shall make good any imperfections in the resulting finish as required by the Engineer. Internal ties and embedded metal parts shall be carefully detailed and their use shall be subject to the approval of the Engineer.

1506 Precautions

The following precautions shall be observed:

- i) It shall be ensured that any cut-outs or openings provided in any structural member to facilitate erection of formwork, are closed with the same grade of concrete as that of the structure, after formwork is removed.
- ii) Provision for safe access to the formwork shall be made at all levels as required.
- iii) Close watch shall be maintained to check for settlement of formwork during concreting and any settlement shall be promptly rectified.
- iv) Natural ground shall be checked for bearing capacity and likely settlement before erection of the staging.
- v) It shall be ensured that water used for curing or rain water does not stagnate near the base plate of the staging.

- vi) For shutters used for deep and narrow member, temporary openings in the sides shall be provided to facilitate pouring and compaction of concrete.

1507 Preparation Of Formwork Before Concreting

The inside surfaces of forms shall, except in the case of permanent formwork or where otherwise agreed to by the Engineer, be coated with a release agent supplied by approved manufacturer or of an approved material to prevent adhesion of concrete to the formwork. Release agents shall be applied strictly in accordance with the manufacturer's instructions and shall not be allowed to come in contact with any reinforcement or prestressing tendons and anchorages. Different release agents shall not be used in formwork for exposed concrete.

Before re-use of forms, the following actions shall be taken :

- i) The contact surfaces of the forms shall be cleaned carefully and dried before applying a release agent.
- ii) It should be ensured that the release agent is appropriate to the surface to be coated. The same type and make of release agent shall be used throughout on similar formwork materials and different types should not be mixed.
- iii) The form surfaces shall be evenly and thinly coated with release agent. The vertical surface shall be treated before horizontal surface and any excess wiped out.
- iv) It shall be ensured that the reinforcement or the surface of the hardened concrete shall not come in contact with the release agent.

All forms shall be thoroughly cleaned immediately before concreting.

The Contractor shall give the Engineer due notice before placing any concrete in the forms to permit him to inspect and approve the formwork. However, such inspection shall not relieve the contractor of his responsibility for safety of formwork, men, machinery, materials and finish or tolerances of concrete.

1508 Removal Of Formwork

The scheme for removal of formwork (i.e. de-shuttering and de-centering) shall be planned in advance and furnished to the Engineer for scrutiny and approval. No formwork or any part thereof shall be removed without prior approval of the Engineer.

The formwork shall be so removed as not to cause any damage to concrete. Centerings shall be gradually and uniformly lowered in such a manner as to permit the concrete to take stresses due to its own weight uniformly and gradually to avoid any shock or vibration.

Form work shall not be released unless the concrete has achieved strength of at least twice the stress the concrete may be subjected at the time of the removal of formwork. When no test is conducted for determination of strength of concrete and where the time of removal of formwork is not specified, the same shall be as under :

a)	Walls, piers, abutments, columns and vertical faces of structural members	12 to 48 hours as may be decided by the Engineer
b)	Soffits of Slabs (with props left under)	3 days
c)	Props left under slabs	14 days
d)	Soffits of Girders (with props left under)	7 days
e)	Props (left under girders)	21 days

The above time schedule is applicable when ordinary Portland Cement is used without any admixtures at an ambient temperature exceeding 10°C.

For concrete made with Portland pozzolona cement, Portland slag cement or mineral admixtures, additional cube samples shall be taken for verifying the strength of concrete to decide the time of deshuttering.

Where there are re-entrant angles in the concrete sections, the formwork should be removed at these sections as soon as possible after the concrete has set, in order to avoid cracking due to shrinkage of concrete.

Additional precautions as given in Clause 8.17 of IRC: 87, shall also be followed.

1509 Re-use of Formwork

When the formwork is dismantled, its individual components shall be examined for damage and damaged pieces shall be removed for rectification. Such examination shall always be carried out before their use again. Before re-use all components shall be cleaned of deposits of soil, concrete or other unwanted materials. Threaded parts shall be oiled after cleaning.

All bent steel props shall be straightened before re-use. The maximum permissible deviation from straightness is 1/600 of the length. The maximum permissible axial loads in used props shall be

suitably reduced depending upon their condition. The condition of the timber components, plywood and steel shuttering plates shall be examined closely for distortion and defects before re-use.

1510 Specialised Formwork

Specialised formwork such as slipform, floating caisson and travelling form, wherever used shall be designed and detailed by competent agencies and a set of complete working drawings and installation instructions supplied to the Engineer. In case proprietary equipment is used, the supplier shall furnish drawings, details, installation instructions etc, in the form of manuals along with the formwork.

For slipform, the rate of climb of the formwork shall be designed for each individual case taking into account various parameters including the grade of concrete, concrete strength, concrete temperature, ambient temperature and concrete admixtures.

For floating caisson, the details of fabrication, floating to site and placing in position shall be as given in Clause 1203.5 of these Specifications.

In order to verify the time and sequence of striking/removal of specialised formwork, routine field tests for the consistency and strength development of concrete are mandatory.

For specialised formwork, the form lining material may be either plywood or steel sheet of appropriate thickness.

1511 TESTS AND STANDARDS OF ACCEPTANCE

The materials shall be tested in accordance with these Specifications and shall meet the prescribed criteria. The work shall conform to these Specifications and shall meet the prescribed standards of acceptance.

1512 Measurements For Payment

Unless stated otherwise, the rate for concrete in plain concrete or reinforced concrete or prestressed concrete, shall be deemed to include all formwork required in accordance with this Section, which shall not be measured separately.

Where it is specifically stipulated in the Contract that the formwork shall be paid for separately, measurement of formwork shall be taken in square metres of the surface area of concrete which is in contact with formwork.

1513 Rate

The unit rate of plain concrete or reinforced concrete or prestressed concrete as defined in respective Sections of these Specifications, shall be deemed to cover the costs of all formwork and staging, including cost of all materials, labour, tools and plant required for design, construction and removal of formwork and supervision as described in this Section including properly supporting the members until the concrete is cured, set and hardened as required.

Where the contract unit rate for formwork is specially provided as a separate item in the contract, it shall include the cost of all materials, labour, tools and plant required for design, construction and removal of formwork and supervision as described in this Section including properly supporting the members until the concrete is cured, set and hardened as required.

1700

Structural concrete

1701 Description

The work shall consist of producing, transporting, placing and compacting of structural concrete including fixing formwork and temporary works etc. and incidental construction in accordance with these Specifications and in conformity with the lines, grades and dimensions, as shown on the drawings or as directed by the Engineer.

1702 Materials

All materials shall conform to Section 1000 of these Specifications.

1703 Grades Of Concrete

1703.1 The grades of concrete shall be designated by the characteristic strength as given in Table 1700-1, where the characteristic strength is defined as the strength of concrete below which not more than 5 percent of the test results are expected to fall.

table 1700-1 : Grades of Concrete

type of Concrete/Grade designation			Characteristic strength in MPa
nominal Mix Concrete	standard Concrete	High Performance Concrete	
M15	M15		15
M20	M20		20
	M25		25
	M30	M30	30
	M40	M35	35
	M45	M40	40
	M50	M45	45
		M50	50
		M55	55
		M60	60
		M65	65
		M70	70
		M75	75
		M80	80
		M85	85
		M90	90

- 1) Normal Mix Concrete is made on the basis of nominal mix proportioned by weight of its main ingredients – cement, coarse and fine aggregates and water.
- 2) Standard concrete is made on the basis of design mix proportioned by weight of its ingredients, which in addition to cement, aggregates and water, may contain chemical admixtures to achieve certain target values of various properties in fresh condition, achievement of which is monitored and controlled during production by suitable tests. Generally, concrete of grades up to M50 are included in this type.
- 3) High Performance Concrete is similar to standard concrete but contains additional one or more mineral admixtures providing binding characteristics and partly acting as inert filler material which increases its strength, reduces its porosity and modifies its other properties in fresh as well as hardened condition. Concrete of grades up to M90 are included in this type.
- 4) For concrete of grades higher than M90, the design parameters may be obtained from specialized literature and experimental results.

1703.2 The minimum grades of concrete and corresponding minimum cement content and maximum water/cement ratios for different exposure conditions shall be as indicated in Table 1700-2.

1703.3 For concrete subjected to sulphate attack the minimum grades of concrete, minimum cement content and maximum water/cement ratios and types of cement for different concentration of sulphate content shall be as indicated in Table 1700-3.

table 1700-2 : Requirement of Concrete for different exposure Condition using 20 mm aggregate

exposure Condition	Maximum Water Cement Ratio	Minimum Cement Content, kg/m ³	Minimum Grade of Concrete
Moderate	0.45	340	M25
Severe	0.45	360	M30
Very Severe	0.40	380	M40

Note:

- i) All three provisions given in the above table for a particular exposure condition, shall be satisfied.
- ii) The term cement for maximum w/c ratio and minimum cement content shown in Table includes all cementitious materials mentioned in Clause 1715.2. The maximum limit of flyash and ground granulated blast furnace slag in the blended cement shall be as specified in IS:1489 (Part 1) and IS:455 respectively.
- iii) For plain cement concrete, with or without surface reinforcement, the minimum grade of

concrete can be lowered by 5 MPa and maximum water/cement ratio exceeded by 0.05.

Cement content shown in the above table shall be increased by 40 kg/m³ for use of 12.50 mm nominal size aggregates and decreased by 30 kg/m³ for use of 40 mm nominal size aggregates.

table 1700-3 : Requirement of Concrete exposed to sulphate attack

Class	Concentration of sulphates as so ₃			type of Cement (note ii)	Minimum Cement Content, kg/m ³	Maximum Water / Cement Ratio	Minimum Grade of Concrete
	in soils		in Ground Water, g/l				
	total so ₃ , %	so ₃ in 2:1 Water: soil extract, g/l					
1)	Traces	< 1.0	< 0.3	-OPC, PPC or PSC	280	0.5	M25
2)	2.0 to 0.5	1.0 to 1.9	0.3 to 1.2	-OPC, PPC or PSC -SRPC	330	0.5	M25
3)	0.5 to 1.0	1.9 to 3.1	1.2 to 2.5	-SRPC, -PPC or PSC	330 350	0.5 0.45	M25 M30
4)	1.0 to 2.0	3.1 to 5.0	2.5 to 5.0	-SRPC	370	0.45	M35
5)	>2.0	>5.0	>5.0	-SRPC with protective coatings	400	0.4	M40

Note: If the requirements of maximum water/cement ratio, minimum grade of concrete and minimum cement content from other durability considerations as given in Table 1700-2 are more stringent than those given in this table, then the former will govern.

OPC: Ordinary Portland Cement, PPC: Portland Pozzolona Cement. PSC: Portland Slag Cement, SRPC: Sulphate Resisting Portland Cement.

The minimum cement content shall be as low as possible but not less than the quantities specified in Table 1700-2 and 1700-3.

The maximum cement content excluding any mineral admixtures (Portland cement component alone) shall not exceed 450 kg/cu.m.

1703.4 Concrete used in any component or structure shall be specified by designation along with prescribed method of design of mix i.e. 'Design Mix' or 'Nominal Mix'. For all items of concrete, only design mix shall be used, except where nominal mix concrete is permitted as per drawing or by the Engineer. Nominal mix may be permitted only for minor bridges and culverts or other incidental construction, where strength requirements are upto M 20 only. Nominal mix may also be permitted for non-structural concrete or for screed below open foundations.

1703.5 If the Contractor so proposes, the Engineer may permit the use of concrete of higher grade than that specified on the drawing, provided the higher grade concrete meets the specifications applicable. The additional cost of such higher grade concrete shall be borne by the Contractor.

1704 Proportioning Of Concrete

Prior to the start of construction, the Contractor shall design the mix in case of design mix concrete or propose nominal mix in case of nominal mix concrete, and submit to the Engineer for approval, the proportions of materials, including admixtures to be used. Water-reducing admixtures (including plasticisers or super-plasticisers) may be used at the Contractor's option, subject to the approval of the Engineer.

1704.1 Requirements of Consistency

The mix shall have the consistency which will allow proper placement and compaction in the required position. Every attempt shall be made to obtain uniform consistency. Slump test shall be used to measure consistency of the concrete.

The optimum consistency for various types of structures shall be as indicated in Table 1700-4, or as directed by the Engineer. The slump of concrete shall be checked as per IS:516.

table 1700-4 : Requirements of Consistency

type		slump (mm) (at the time of Placing of Concrete)
1)	a) Structure with exposed inclined surface requiring low slump concrete to allow proper compaction	25
	b) Plain cement concrete	25
2)	RCC structure with widely spaced reinforcements; e.g. solid columns, piers, abutments, footings, well steining	40 – 50
3)	RCC structure with fair degree of congestion of reinforcement; e.g. pier and abutment caps, box culverts, well curb, well cap, walls with thickness greater than 300 mm	50 – 75
4)	RCC and PSC structure with highly congested reinforcements e.g. deck slab girders, box girders, walls with thickness less than 300 mm	75 – 125
5)	Underwater concreting through tremie e.g. bottom plug, cast in-situ piling	150 – 200

Notwithstanding the optimum consistency indicated against Sl. No. 1 to 3, the situation should be property assessed to arrive at the desired workability with the adjustment of admixture in each case, where the concrete is to be transported through transit mixer and placed using concrete pump. Under these circumstances, the optimum consistency during placement for the items of work of Sl. No. 1 to 3, can be considered ranging from 75 mm to 150 mm. This is, however, subject to satisfying the other essential criteria of strength, durability etc. and approval of the Engineer.

1704.2 Requirements for design Mixes

1704.2.1 target Mean strength

The target mean strength of specimen shall exceed the specified characteristic compressive strength by at least the current margin.

- i) The current margin for a concrete mix shall be determined by the Contractor and shall be taken as 1.64 times the standard deviation of sample test results taken from at least 40 separate batches of concrete of nominally similar proportions produced at site by the same plant under similar supervision, over a period exceeding 5 days, but not exceeding 6 months.
- ii) Where there is insufficient data to satisfy the above, the current margin for the initial design mix shall be taken as given in Table 1700-5 :

table 1700-5 : Current Margin for initial design Mix

Concrete Grade	Current Margin (MPa)	target Mean strength (MPa)
M 15	10	25
M 20	10	30
M 25	11	36
M 30	12	42
M 35	12	47
M 40	12	52
M 45	13	58
M 50	13	63
M 55	14	69
M60	14	74
M 65	15	80
M 70	15	85
M 75	15	90
M 80	15	95

M85	16	101
M90	16	106

The initial current margin given in Table 1700-5 shall be used till sufficient data is available to determine the current margin as per Sub-Clause 1704.2.1(i).

1704.2.2 trial Mixes

The Contractor shall give notice to the Engineer to enable him to be present at the time of carrying out trial mixes and preliminary testing of the cubes. Prior to commencement of trial mix design, all materials forming constituents of proposed design mix should have been tested and approval obtained in writing from the Engineer. Based on test results of material, draft mix design calculation for all grades of concrete to be used in the works, shall be prepared after taking into account the provisions in the Contract Technical Specifications, Guidelines of IS:10262, IS:SP:23 and IRC:112 and submitted to the Engineer for approval. Prior to commencement of concreting, trial mix design shall be performed for all grades of concrete and trial mix which has been found successful, shall be submitted by the Contractor and approval obtained. During concreting with the approved trial mix design, if source of any constituents is changed, the mix design shall be revised and tested for satisfying the strength requirements.

The initial trial mixes shall be carried out in a laboratory approved by the Engineer. However, Engineer may permit the initial trial mixes to be prepared at the site laboratory of the Contractor, if a full fledged concrete laboratory has been established well before the start of construction, to his entire satisfaction. Sampling and testing procedures shall be in accordance with these Specifications.

When the site laboratory is utilized for preparing initial mix design, the concrete production plant and means of transport employed to make the trial mixes shall be similar to those proposed to be used in the works.

For each trial mix, a set of six cubes shall be made from each of three consecutive batches for purposes of testing. Three cubes from each set of six shall be tested at an age of 28 days and three at an earlier age approved by the Engineer. The cubes shall be made, cured, stored, transported and tested in accordance with these Specifications. The mean strength of the nine cubes at 28 days shall exceed the specified characteristic strength by the current margin minus 3.5 MPa.

1704.2.3 Control of strength of design Mixes

a) Adjustment to Mix Proportions

Adjustment to mix proportions arrived at in the trial mixes, shall be made subject to the Engineer's approval, in order to minimize the variability of

strength and to maintain the target mean strength. Such adjustments shall not be taken to imply any change in the current margin.

b) Change of Current Margin

When required by the Engineer, the Contractor shall recalculate the current margin in accordance with Clause 1704.2.1. The recalculated

value shall be adopted as directed by the Engineer, and it shall become the current margin for concrete produced thereafter.

c) Additional Trial Mixes

In case any changes are observed in the properties of fresh concrete and/or strength of hardened concrete on the basis of early age tests, additional mixes and tests shall be carried out during production, so as to control and bring the quality of concrete within acceptable limits. In case of any change in the source or properties of materials, the design of mix shall be established afresh.

1704.3 Requirements of nominal Mix Concrete

Requirements for nominal mix concrete unless otherwise specified shall be as given in **table 1700-6**.

table 1700-6 : Requirements for nominal Mix Concrete

Concrete Grade	total Quantity of dry aggregate by Mass per 50 kg of Cement to be taken as the sum of individual Masses of Fine and Coarse aggregates (kg)	Proportion of Fine to Coarse aggregate (by Mass)	Maximum Quantity of Water for 50 kg of Cement (litres)	
			PCC	RCC
M 15	350	Generally 1:2, subject to upper limit 1:1.5 and lower limit of 1:2.5	25	
M 20	250		25	22

1704.4 additional Requirements

Concrete shall meet any other requirements as specified on the drawing or as directed by the Engineer. The overall limits of deleterious substances in concrete shall be as follows:

- a) Total acid soluble chloride content in the concrete mix expressed as

chloride ions shall not exceed the following values by mass of cement.

Prestressed concrete	0.10 percent
Reinforced concrete (in severe, very severe or extreme exposure condition)	0.20 percent
Reinforced concrete in moderate exposure condition	0.30 percent

- b) The total water soluble sulphate content of the concrete mix expressed as SO_3 , shall not exceed 4 percent by mass of cement in the mix.

For concrete made with Portland pozzolona cement, Portland blast furnace slag cement or mineral admixtures, the setting time and rate of gain of strength are different from those for concrete made with OPC alone. Such modified properties shall be taken into account while deciding the de-shuttering time, curing period, early age loading and time of prestressing. Additional cube samples may be required to be taken for verifying the concrete properties.

1704.5 suitability of Proposed Mix Proportions

The Contractor shall submit the following information for the Engineer's approval :

- a) Nature and source of each material
- b) Quantities of each material per cubic metre of fully compacted concrete
- c) Either of the following :
 - i) Appropriate existing data as evidence of satisfactory previous performance for the target mean strength, current margin, consistency and water/cement ratio and any other additional requirement (s) as specified.
 - ii) full details of tests on trial mixes.
- d) Statement giving the proposed mix proportions for nominal mix concrete

Any change in the source of material or in the mix proportions shall be subject to the Engineer's prior approval.

1704.6 Checking of Mix Proportions and Water/Cement Ratio

In proportioning concrete, the quantity of both cement and aggregate shall be determined by weight. Where the weight of cement per bag as given by the manufacturer is accepted, a reasonable

number of bags shall be weighed separately to check the net weight. Where cement is weighed from bulk stock at site and not by bag, it shall be weighed separately from the aggregates. Water shall either be measured by volume in calibrated tanks or weighed. All measuring equipment shall be maintained in a clean and serviceable condition. Their accuracy shall be periodically checked.

The specified water/cement ratio shall always be kept constant and at its correct value. To this end, moisture content in both fine and coarse aggregates shall be determined as frequently as possible, the frequency for a given job being determined by the Engineer according to the weather conditions. The amount of water to be added shall then be adjusted to compensate

for variations in the moisture content. For the determination of moisture content in the aggregates IS:2386 (Part III) shall be referred. Suitable adjustments shall also be made in the weight of aggregates to allow for their variation in weight due to variation in their moisture content.

1704.7 Grading of aggregates for Pumped Concrete

Materials for pumped concrete shall be batched consistently and uniformly. Maximum size of aggregate shall not exceed one-third of the internal diameter of the pipe.

The grading of aggregates shall be continuous and shall have sufficient ultra fine materials (material finer than 0.25 mm). Proportion of fine aggregates passing through 0.25 mm shall be between 15 and 30 percent and that passing through 0.125 mm sieve shall not be less than 5 percent of the total volume of aggregate. Admixtures to increase workability can be added. When pumping long distances and in hot weather, set-retarding admixtures can be used. Fluid mixes can be pumped satisfactorily after adding plasticisers and super plasticisers. Suitability of concrete shall be verified by trial mixes and by performing pumping test.

1705 ADMIXTURES

1705.1 Chemical admixtures

Chemical admixtures such as superplasticisers, or air entraining, water reducing, accelerating and retarding agents for concrete, may be used with the approval of the Engineer.

As the selection of an appropriate concrete admixture is an integral part of the mix design, the manufacturers shall recommend the use of any one of their products only after obtaining complete information of all the actual constituents of concrete as well as methodologies of manufacture, transportation and compaction of concrete proposed to be used in the work. Admixtures/additives conforming to IS:9103 may be used subject to approval of the Engineer. However,

admixtures/additives generating hydrogen or nitrogen and containing chlorides, nitrates, sulphides, sulphates or any other material likely to adversely affect the steel or concrete, shall not be permitted.

The general requirements for admixtures are given in Clause 1007 of these Specifications.

Compatibility of the admixtures with the cement and any other pozzolona or hydraulic additions shall be ensured by for avoiding the following problems

- i) Requirement of large dosage of superplasticiser for achieving the desired workability,
- ii) Excessive retardation of setting,
- iii) Excessive entrainment of large air bubbles,
- iv) Unusually rapid stiffening of concrete,
- v) Rapid loss of slump
- vi) Excessive segregation and bleeding.

1705.2 Mineral admixtures

For use of mineral admixtures, refer Clauses 1714.1 and 1715.2.

1706 Size Of Coarse Aggregates

The size (maximum nominal) of coarse aggregates for concrete to be used in various components shall be as given in Table 1700-7.

table 1700-7 : Maximum nominal size of Coarse aggregates

Components	Maximum nominal size of Coarse aggregate (mm)
I) RCC well curb	20
ii) RCC/PCC well steining	40
iii) Well cap or Pile Cap Solid type piers and abutments	40
iv) RCC work in girder, slabs wearing coat, kerb, approach slab, hollow piers and abutments, pier/abutment caps, piles	20
v) PSC Work	20
vi) Any other item	As specified by the Engineer

Maximum nominal size of aggregates shall also be restricted to the smaller of the following values :

- a) 10 mm less than the minimum lateral clear distance between individual reinforcements
- b) 10 mm less than the minimum clear cover to the reinforcement
- c) One quarter of minimum thickness of member

The proportions of the various individual sizes of aggregates shall be so adjusted that the grading produces the densest mix and the grading curve corresponds to the maximum nominal size adopted for the concrete mix.

1707 Equipment

Unless specified otherwise, equipment for production, transportation and compaction of concrete shall be as under :

- a) Production of Concrete :
 - i) For overall bridge length of less than 200 m – batch type concrete mixer, diesel or electric operated, with a minimum size of 200 litres automatic water measuring system and integral weigher (hydraulic/pneumatic type).
 - ii) For overall bridge length of 200 m or more – concrete batching and mixing plant fully automatic, with minimum capacity of 15 cum per hour.

All measuring devices of the equipment shall be maintained in a clean and serviceable condition. Their accuracy shall be checked over the range in use, when set up at each site and thereafter, periodically as directed by the Engineer.

The accuracy of the measuring devices shall fall within the following limits :

Measurement of Cement	:	± 3 percent of the quantity of cement in each batch
Measurement of Water	:	± 3 percent of the quantity of water in each batch
Measurement of Aggregate	:	± 3 percent of the quantity of aggregate in each batch
Measurement of Admixture	:	± 3 percent of the quantity of admixture in each batch

- b) Transportation of Concrete:
- i) Concrete dumpers minimum 2 tonnes capacity
 - ii) Powered hoists minimum 0.5 tonne capacity
 - iii) Chutes
 - iv) Buckets handled by cranes
 - v) Transit truck mixer
 - vi) Concrete pump
 - vii) Concrete distributor booms
 - viii) Belt conveyor
 - ix) Cranes with skips
 - x) Tremies
- c) For Compaction of Concrete :
- i) Internal vibrators size 25 mm to 70 mm
 - ii) Form vibrators minimum 500 watts
 - iii) Screed vibrators full width of carriageway
(upto two lanes)

1708 Batching, Mixing, Transporting, Placing And Compaction

1708.1 General

Prior to start of concreting, the Contractor shall submit for approval of the Engineer, his programme along with list of equipment proposed to be used by him for batching, mixing, transporting and placing concrete.

1708.2 Batching of Concrete

In batching concrete:

- The quantity of cement, aggregate and mineral admixtures, if used, shall be determined by mass.
- Chemical admixtures, if solid, shall be determined by mass.
- Liquid admixtures may be measured in volume or mass, and
- Water shall be weighed or measured by volume in a calibrated tank.

The concrete shall be sourced from on-site or off-site batching and mixing plants, or from approved Ready Mixed Concrete plants, preferably having quality certification.

Except where supply of properly graded aggregate of uniform quality can be maintained over a period of work, the grading of aggregate should be controlled by obtaining the coarse aggregate in different sizes and blending them in the right proportions when required, the different sizes being stocked in separate stock piles. The materials should be stock piled several hours, preferably a day before use. The grading of coarse and fine aggregate should be checked as frequently as possible to ensure that the specified grading is maintained.

The water/cement ratio shall always be maintained constant at its correct value. To this end, determination of moisture content in both fine and coarse aggregates shall be made as frequently as possible, depending on weather conditions. The amount of added water shall be adjusted to compensate for any observed variations in the moisture content. To allow for the variation in mass of aggregate due to variation in moisture content, suitable adjustment in the mass of aggregate, shall also be made. Accurate control shall be kept on the quantity of mixing water, which when specified, shall not be changed without approval.

1708.3 Mixing Concrete

1708.3.1 Mixing at site

All concrete shall be machine mixed. In order to ensure uniformity and good quality of concrete the ingredients shall be mixed in a power driven batch mixer with hopper and suitable weigh batching arrangement or in a central mix plant. Hand mixing shall not be permitted. The mixer or the plant shall be at an approved location considering the properties of the mixes and the transportation arrangements available with the Contractor. The mixer or the plant shall be approved by the Engineer.

Mixing shall be continued till materials are uniformly distributed, a uniform colour of the entire mass is obtained and each individual particle of the coarse aggregate shows complete coating of mortar containing its proportionate amount of cement. In no case shall mixing be done for less than 2 minutes. It shall be ensured that the mixers are not loaded above their rated capacities and are operated at a speed recommended by the manufacturer. When mineral admixtures are added at the mixing stage, their thorough and uniform blending with cement shall be ensured, if necessary by longer mixing time. The addition of water after the completion of the initial mixing operation, shall not be permitted.

Mixers which have been out of use for more than 30 minutes shall be thoroughly cleaned before putting in a new batch and also before changing from one type of cement to another.

1708.3.2 Ready Mix Concrete

Use of ready mix concrete proportioned and mixed off the project site and delivered to site in a freshly mixed and unhardened state conforming to IS:4926, shall be allowed with the approval of the Engineer.

1708.4 transporting Concrete

Mixed concrete shall be transported from the place of mixing to the place of final deposit as rapidly as possible by methods which will prevent the segregation or loss of the ingredients. The method of transporting or placing of concrete shall be approved by the Engineer. Concrete shall be transported and placed as near as practicable to its final position so that no contamination, segregation or loss of its constituents materials take place.

Concrete may be transported by transit mixers or properly designed buckets or by pumping. Transit mixers or other hauling equipment when used should be equipped with the means of discharge of concrete without segregation. During hot or cold weather, concrete shall be transported in deep containers. Other suitable methods to be reduce the loss of water by evaporation in hot weather and heat loss in cold weather may also be adopted.

When concrete is conveyed by chute, the plant shall be of such size and design as to ensure practically continuous flow. Slope of the chute shall be so adjusted that the concrete flows without excessive quantity of water and without any segregation of its ingredients. The delivery end of the chute shall be as close as possible to the point of deposit. The chute shall be thoroughly flushed with water before and after each working period and the water used for this purpose shall be discharged outside the formwork.

In case concrete is to be transported by pumping, the fresh concrete should have adequate fluidity and cohesiveness to be pumpable. Proper concrete mix proportioning and initial trials should ensure this. The conduit shall be primed by pumping a batch of mortar through the line to lubricate it. Once the pumping is started, it shall not be interrupted, as concrete standing idle in the line is liable to cause plug. The operator shall ensure that some concrete is always there in the pump's receiving hopper during operation. The lines shall always be maintained clean and free of dents.

Pipelines from the pump to the placing area shall be laid with minimum bends. For large quantity placements, standby pumps shall be available. Suitable air release valves, shutoff valves etc. shall be provided as per site requirements. The pumping of priming mix i.e. rich mix of creamy consistency, to lubricate the concrete pump and pipelines, shall precede the pumping of concrete. Continuous

pumping shall be done to the extent possible. After concreting, the pipelines and accessories shall be cleaned immediately. The pipes for pumping shall not be made of material which has adverse effect on concrete. Aluminium alloy pipelines shall not be used.

1708.5 Placing of Concrete

All formwork and reinforcement contained in it shall be cleaned and made free from standing water, dust, snow or ice immediately before placing of concrete.

No concrete shall be placed in any part of the structure until the approval of the Engineer has been obtained. If concreting is not started within 24 hours of the approval being given, the approval shall have to be obtained again from the Engineer. Concreting shall proceed continuously over the area between the construction joints. Fresh concrete shall not be placed against concrete which has been in position for more than 30 minutes, unless a proper construction joint is formed.

The concrete shall be deposited as nearly as practicable in its original position to avoid re-handling. Methods of placing should be such as to preclude segregation. Care should be taken to avoid displacement of reinforcement or movement of formwork. To achieve this, concrete should be lowered vertically in the form and horizontal movement of concrete inside the forms should, as far as practicable, be minimised.

The concrete shall be placed and compacted before its initial setting so that it is amenable to compaction by vibration. The workability of concrete at the time of placement shall be adequate for the compaction equipment to be used. If there is considerable time gap between mixing and placing of concrete, as in the case of ready mixed concrete plants or off-site batching and mixing plants, concrete mix shall be designed to have appropriately higher workability at the time of discharge from the mixer, in order to compensate the loss of workability during transit. This is generally achieved by suitable chemical admixtures. Keeping these considerations in view, the general requirement for ready mixed concrete plants or off-site batching and mixing plants, is that concrete shall be discharged from the truck mixer within two hours of the time of loading. A longer period may be permitted if suitable retarding admixtures are used.

In wall forms, drop chutes attached to hoppers at the top should preferably be used to lower concrete to the bottom of the form. As a general guidance, the permissible free fall of concrete may not exceed 1.5 metres and under no circumstances shall it be more than 2 metres. When free fall of larger height is involved, self compacting concrete having adequate fluidity, cohesiveness and viscosity and which uniformly and completely fills every corner of the formwork by its own weight without segregation, shall be used.

Except where otherwise agreed to by the Engineer, concrete shall be deposited in horizontal layers to a compacted depth of not more than 450 mm when internal vibrators are used and not more than 300 mm in all other cases.

Concrete when deposited shall have temperature of not less than 5°C and preferably not more than 30°C and in no case more than 40°C. In case of site mixing, fresh concrete shall be placed and compacted in its final position within 30 minutes of its discharge from the mixer. When the concrete is carried in properly designed agitator operating continuously, the concrete shall be placed and compacted within 1 hour of the addition of cement to the mix and within 30 minutes of its discharge from the agitator. It may be necessary to add retarding admixtures to concrete, if trials show that the periods indicated above are unacceptable. In all such matters, the Engineer's decision shall be final.

1708.6 Compaction of Concrete

Concrete shall be thoroughly compacted by vibration or other means during placing and worked around the reinforcement, tendons or duct formers, embedded fixtures and into corners of the formwork to produce a dense homogeneous void-free mass having the required surface finish. When vibrators are used, vibration shall be done continuously during the placing of each batch of concrete until the expulsion of air has practically ceased and in a manner that does not promote segregation. Over-vibration shall be avoided to minimize the risk of forming a weak surface layer. When external vibrators are used, the design of formwork and disposition of vibrator shall be such as to ensure efficient compaction and to avoid surface blemishes. Vibrations shall not be applied through reinforcement and where

vibrators of immersion type are used, contact with reinforcement and all inserts like ducts etc., shall be avoided.

When internal vibrators are used, they shall be inserted vertically to the full depth of the layer being placed and ordinarily shall penetrate the layer below for a few centimetres. The vibrator should be kept in place until air bubbles cease escaping from the surface and then withdrawn slowly to ensure that no hole is left in the concrete, care being taken to see that it remains in continued operation while being withdrawn. The internal vibrators shall be inserted in an orderly manner and the distance between insertions should be about one and half times the radius of the area visibly affected by vibration. Additional vibrators in serviceable condition shall be kept at site so that they can be used in the event of breakdown.

Mechanical vibrators used shall comply with IS:2502, IS:2506, IS:2514 and IS:4656.

1709 Construction Joints

Construction joints shall be avoided as far as possible. In no case shall the locations of such joints be changed or increased from those shown on the drawings except with the express approval of the Engineer.

Joints should be positioned where they are readily accessible for preparation and concreting. Construction joints should be positioned to minimize the effects of the discontinuity of the durability, structural integrity and appearance of the structure. As far as possible, joints should be provided in non-aggressive zones, but if joints in aggressive zones cannot be avoided, they should be sealed. Joints should be located away from the regions of maximum stress caused by loading; particularly where shear and bond stresses are high.

In beams and slabs joints should not be near the supports. Construction joints between slabs and ribs in composite beams, shall be avoided. For box girders, there shall be no construction joint between the soffit and webs.

Joints should be either vertical or horizontal. For a vertical construction joint, the lifts of concrete shall finish level or at right angles to the axis of the member. Concreting shall be continued right up to the joint.

Before resuming work at a construction joint when concrete has not yet fully hardened, all laitance shall be removed thoroughly. The surface shall be roughened, taking care to avoid dislodgement of coarse aggregates. Concrete shall be brushed with a stiff brush soon after casting, while the concrete has only slightly stiffened. If the concrete has partially hardened, it may be treated by wire brushing or with a high pressure water jet, followed by drying with an air jet, immediately before the new concrete is placed. Fully hardened concrete shall be treated with mechanical hand tools or grit blasting, taking care not to split or crack aggregate particles. The practice of first placing a layer of mortar or grout when concreting joints, shall

be avoided. The old surface shall be soaked with water, without leaving puddles, immediately before starting concreting. The new concrete shall be thoroughly compacted against it.

Where there is likely to be a delay before placing the next concrete lift, protruding reinforcement shall be protected. In all cases, where construction joints are made, the joint surface shall not be contaminated with release agents, dust, or sprayed curing membrane and reinforcement shall be firmly fixed in position at the correct cover.

The sequence of concreting, striking of forms and positioning of construction joints for every individual structure, shall be decided well in advance of the commencement of work.

1710 **Concreting Under Water**

When it is necessary to deposit concrete under water, the methods, equipment, materials and proportions of mix to be used, shall be got approved from the Engineer before any work is started.

Concrete shall not be placed in water having a temperature below 5°C. The temperature of the concrete, when deposited, shall not be less than 16°C, nor more than 30°C.

Coffer dams or forms shall be sufficiently tight to ensure still water conditions, if practicable, and in any case to reduce the flow of water to less than 3 m per minute through the space into which concrete is to be deposited. Coffer dams or forms in still water shall be sufficiently tight to prevent loss of mortar through the joints in the walls. Pumping shall not be done while concrete is being placed, or until 24 hours thereafter. To minimise the formation of laitance, care shall be exercised not to disturb the concrete as far as possible while it is being deposited.

All under water concreting shall be carried out by tremie method only. The number and spacing of the tremies should be worked out to ensure proper concreting. However, it is necessary to have a minimum number of 2 tremies for any concreting operation, so that even if one of the tremies goes out of commission during concreting, the other one can be used to complete the work. The tremie concreting when started, should continue without interruption for the full height of the member being concreted. The capacity of the concrete production and placement equipment should be sufficient to enable the underwater concreting to be completed uninterrupted within the stipulated time.

The top section of the tremie shall have a hopper large enough to hold one full batch of the mix or the entire contents of the transporting bucket, as the case may be. The tremie pipe shall not be less than 200 mm in diameter and shall be large enough to allow a free flow of concrete and strong enough to withstand the external pressure of the water in which it is suspended, even if a partial vacuum develops inside the pipe. Preferably, flanged steel pipe of adequate strength shall be used. A separate lifting device shall be provided for each

tremie pipe with its hopper at the upper end. Unless the lower end of the pipe is equipped with an approved automatic check valve, the upper end of the pipe shall be plugged with a wadding of gunny sacking or other approved material before delivering the concrete to the tremie pipe through the hopper, so that when the concrete is forced down from the hopper to the pipe, it will force the plug (and along with it any water in the pipe) down the pipe and out of the bottom end, thus establishing a continuous stream of concrete. It will be necessary to raise the tremie slowly in order to allow a uniform flow of concrete. At all times after placing of concrete is started and until all the required quantity has been placed, the lower end of the tremie pipe shall be kept below the surface of the plastic concrete and shall not be taken out of concrete. This will cause the concrete to build up from below instead of flowing out over the surface and thus avoid formation of layers of laitance. It is advisable

to use retarders or suitable superplasticizers to retard the setting time of concrete, which shall be established before the commencement of work.

1711 concreting in extreme weather 1711.1
Concreting in Cold Weather

Where concrete is to be deposited at or near freezing temperature, precautions shall be taken to ensure that at the time of placing, it has a temperature of not less than 5°C and that the temperature shall be maintained above 4°C until the concrete has hardened. When necessary, concrete ingredients shall be heated before mixing but cement shall not be heated artificially other than by the heat transmitted to it from other ingredients of the concrete. Stock-piled aggregate may be heated by the use of dry heat or steam. Aggregates shall not be heated directly by gas or on sheet metal over fire. In general, the temperature of aggregates or water shall not exceed 65°C. Salt or other chemicals shall not be used for the prevention of freezing. No frozen material or materials containing ice shall be used. All concrete damaged by frost shall be removed. Concrete exposed to freezing weather shall have entrained air and the water content of the mix shall not exceed 30 litres per 50 kg of cement. To counter slower setting of concrete, accelerators can be used with the approval of the Engineer. However, accelerators containing chloride shall not be used.

1711.2 Concreting in Hot Weather

When depositing concrete in hot weather, precautions shall be taken so that the temperature of wet concrete does not exceed 30°C while placing. This shall be achieved by using chilled mixing water, using crushed ice as a part of mixing water, shading stock piles of aggregates from direct rays of the sun, sprinkling the stock piles of coarse aggregate with water to keep them moist, limiting temperature of cement below 30°C at the time of use, starting curing before concrete dries out and restricting time of concreting as far as possible to early mornings and late evenings. When ice is used to cool mixing water, it will be considered as part of the water in design mix. Under no circumstances shall the mixing operation be considered complete until all ice in the mixing drum has melted. The Contractor will be required to state

his methodology for the Engineer's approval when temperatures of concrete are likely to exceed 30°C during the work.

1712 Protection And Curing

1712.1 General

Concreting operations shall not commence until adequate arrangements for concrete curing have been made by the Contractor. Curing and protection of concrete shall start immediately after compaction of the concrete.

The concrete shall be protected from:

- a) Premature drying out particularly by solar radiation and wind

- b) High internal thermal gradients
- c) Leaching out by rain and flowing water
- d) Rapid cooling during the first few days after placing
- e) Low temperature or frost
- f) Vibration and impact which may disrupt the concrete and interfere with its bond to the reinforcement.
- g) Vibration caused by traffic including construction traffic.

Concrete shall be protected, without allowing ingress of external water, by means of wet (not dripping) gunny bags, hessian etc. Once the concrete has attained some degree of hardening (approximate 12 hrs after mixing), moist curing shall commence and be continued through the requisite period. Where members are of considerable size and length, with high cement content, accelerated curing methods may be applied, as approved by the Engineer.

1712.2 Water Curing

Water for curing shall be as specified in **section 1000** of these specifications.

Sea water shall not be used for curing. Sea water shall not come into contact with concrete members before they have attained adequate strength.

The concrete should be kept constantly wet by ponding or covering or use of sprinklers/ perforated pipes for a minimum period of 14 days after concreting, except in the case of concrete with rapid hardening cement, where it can be reduced to 5 days. Water should be applied on surfaces after the final set. Curing through watering shall not be done on green concrete. On formed surfaces, curing shall start immediately after the forms are stripped. The concrete shall be kept constantly wet with a layer of sacking, canvas, hessian or similar absorbent material.

1712.3 steam Curing

Where steam curing is adopted, it shall be ensured that it is done in suitable enclosure to contain the live steam in order to minimize moisture and heat losses. The initial application of the steam shall be after about four hours of placement of concrete to allow the initial set of the concrete to take place.

Where retarders are used, the waiting period before application of the steam shall be increased to about six hours.

The steam shall be at 100 percent relative humidity to prevent loss of moisture and to provide excess moisture for proper hydration of the cement. The application of steam shall not be directly on the concrete. Steam curing is applied in enclosures or tunnels through which concrete members are transported on a conveying system. Alternatively, portable enclosures or plastic covers are placed over precast members and steam is supplied to the enclosures. The rate of increase or decrease of temperature should not be more than 10°C to 20°C per hour and the maximum temperature shall be about 70°C. The maximum temperature shall be maintained until the concrete has attained the desired strength required at the end of steam curing period and shall be decided by prior trials. When steam curing is discontinued, the air temperature shall not drop at a rate exceeding 10°C per hour, until a temperature of about 10°C above the ambient temperature outside has been reached. Steam curing of concrete shall be followed by water curing for at least 7 days. The concrete shall not be exposed to temperatures below freezing for at least six days after curing.

1712.4 Curing Compound

Membrane forming curing compounds consisting of waxes, resins, chlorinated rubbers etc. may be permitted by the Engineer in special circumstances. Curing compounds shall not be used on any surface which requires further finishing to be applied. All construction joints shall be moist cured and no curing compound shall be permitted in locations where concrete surfaces are required to be bonded together.

Liquid membrane forming compounds shall conform to ASTM C 309 and the curing efficiency shall be as per ASTM C 156.

Curing compounds shall be continuously agitated during use. All concrete cured by this method shall receive two applications of the curing compound. The first coat shall be applied immediately after acceptance of concrete finish. If the surface is dry, the concrete shall be saturated with water and curing compound applied as soon as the surface film of water disappears. The second application shall be made after the first application has set. Placement in more than two coats may be required to prevent streaking. The membrane formed shall be stripped off after 14 days, when curing is complete. Impermeable membranes, such as sheet materials for curing concrete conforming to ASTM C 171 or polyethylene sheeting

covering closely the concrete surface, may also be used to provide effective barrier against evaporation.

1713 Finishing

Immediately after the removal of forms, exposed bars or bolts, if any, shall be cut inside the concrete member to a depth of at least 50 mm below the surface of the concrete and the resulting holes filled

with cement mortar. All fins caused by form joints, all cavities produced by the removal of form ties and all other holes and depressions, honeycomb spots, broken edges or corners, and other defects, shall be thoroughly cleaned, saturated with water and carefully pointed and rendered true with mortar. The mortar shall be of cement and fine aggregate mixed in the proportions used in the grade of concrete that is being finished and of as dry a consistency as possible. Considerable pressure shall be applied in filling and pointing to ensure thorough filling in all voids. Surfaces which have been pointed shall be kept moist for a period of twenty four hours. Special pre-packaged proprietary mortars shall be used where appropriate or where specified in the drawing.

All construction and expansion joints in the completed work shall be left carefully tooled and free from any mortar and concrete. Expansion joint filler shall be left exposed for its full length with clean and true edges.

Immediately on removal of forms, the concrete work shall be examined by the Engineer before any defects are made good. The work that has sagged or contains honeycombing to an extent detrimental to structural safety or architectural appearance of the member, shall be rejected. Surface defects of a minor nature may be accepted. On acceptance of such work, the same shall be rectified as directed by the Engineer.

1714 concrete with Blended cements or mineral admixtures 1714.1 Production of Concrete

In order to improve the durability of the concrete, use of blended cement or blending of mineral admixtures, is permitted. The maximum limit of flyash and ground granulated blast furnace slag in concrete, shall be as specified in Clause 1715.2. Blending at site shall be permitted only through a specific facility with complete automated process control to achieve the specified design quality or through RMC plants with similar facility.

1714.2 Modified Properties

For concrete made with Portland Pozzolona Cement, Portland Blast furnace slag cement or mineral admixtures, the setting time and rate of gain of strength are different from those of concrete made with OPC alone. Cognizance of such modified properties shall be taken

in deciding de-shuttering time, initial time of prestressing, curing period and for early age loading.

1714.3 Compatibility of Chemical admixtures

Compatibility of chemical admixtures and superplasticizers with Portland Pozzolona cement, Portland blast furnace slag cement and mineral admixtures shall be ensured by trials outlined in **Clause 1705**.

1714.4 additional tests

In addition to the strength tests prescribed in other Sections of these Specifications, the following additional tests are required to be carried out from considerations of durability.

i) Rapid Chloride Ion Permissibility Test

Rapid Chloride Ion permeability test on as per ASTM C 1202 at 56 days for extreme, very severe and severe conditions of exposure. The permissible value of Chloride-Ion permeability for extreme condition 800 Coulombs very severe condition 1200 coulombs and severe exposure condition 1500 coulombs.

ii) Water Permeability Test

Water permeability test as per DIN: 1048 Part 5-1991 shall be carried out as described in Clause 1717.2.5.5.

1715 high performance concrete

1715.1 General

High Performance Concrete shall be used where special performance requirements of high strength, high early strength, high workability, low permeability and high durability for severe service environments, are required. Production and use of such concrete in the field shall be carried out with high degree of uniformity between batches and very stringent quality control.

1715.2 Materials

Cement, mineral admixtures, chemical admixtures, aggregates and water shall conform to **section 1000** of these Specifications and this Section.

Flyash when used, shall neither be less than 20 percent nor shall be greater than 35 percent of the total by mass of ordinary Portland cement and flyash and shall conform to grade-1 of IS:3812.

Ground granulated blast furnace (GGBS) slag when used, shall neither be less than 50 percent nor greater than 70 percent of the total mass of ordinary Portland cement and GGBS and shall conform to IS:12089.

Silica fume conforming to IS:15388 shall be used.

The cement content of concrete inclusive of any mineral admixtures shall not be less than 380 kg/m³. The cement content excluding any mineral admixtures (Portland cement content alone) shall not exceed 450 kg/m³. The water/cement (cement plus all cementitious materials) ratio should generally not exceed 0.33 but in no case shall be more than 0.40.

1715.3 Compatibility of admixtures

Compatibility of the superplasticiser and admixtures with the cement and any other Pozzolanic or hydraulic dilutes shall be ensured by trials as outlined under Clause 1705.

1715.4 Characteristic strength and target Mean strength

Characteristic strength and the initial target mean strength of concrete, shall be as given in **table 1700-8**.

The target mean strength shall be calculated as per Clause 1704.2 after obtaining data on standard deviation from sufficient samples.

table 1700-8 : Characteristic Compressive strength and target Mean strength

Grade designation	Specified Characteristic Compressive strength at 28 days (MPa)	target Mean strength (MPa)
M 40	40	52
M 45	45	58
M 50	50	63
M 55	55	69
M 60	60	74
M 65	65	80
M 70	70	85
M 75	75	90
M 80	80	95
M85	85	101
M90	90	106

1715.5 Workability and other Requirements

Workability, concrete mix design, field trial mixes, chloride and sulphate contents shall be as laid down in other Sections of these Specifications.

1715.6 Mixing of Concrete

The concreting plant and means of transportation employed to make trial mixes and to transport them to representative distances shall be similar to the corresponding plant and transport to be used in the works. The optimum sequence of mixing of ingredients shall be established by trials. Mixing time may be longer than in normal grade concrete mixes.

The temperature of concrete at the time of placement shall not exceed 25°C. The temperature of concrete at the mixing stage should be lower, to allow for rise in temperature during transport. When considerable distance of transport is involved, particular attention should be paid to ensure retention of slump as targeted for placement.

1715.7 Prototype testing

Mock-up trials or prototype testing may be carried out to ensure that the concrete can be satisfactorily placed and compacted, taking into account the location of placement and provision of reinforcement, and required adjustments made in concrete mix design and/or detailing of reinforcement.

1715.8 Curing of Concrete

High performance concrete containing silica fume is more cohesive than normal mixes hence, there is a little or no bleeding and no bleed water to rise to the surface to offset water loss due to evaporation. Plastic shrinkage cracking is possible, if curing is not proper. Initial curing should commence soon after initial setting of concrete. Concrete should be covered with moist covers, opaque colour plastic sheets or suitable curing compound. Final moist curing should commence after final setting of concrete and continue for at least 14 days.

1715.9 additional tests for Concrete

Apart from the strength tests prescribed in other Sections of these Specifications, the additional tests as specified under Clause 1714.3, shall also be carried out.

1716 tolerances

Tolerances for dimensions/shape of various components shall be as indicated in these Specifications or shown on the drawings or as directed by the Engineer.

1717 tests and standards of acceptance

1717.1 Concrete shall conform to the surface finish and tolerance as prescribed in these Specifications for respective components.

1717.2 Random sampling and lot by lot acceptance inspection, shall be made for the 28 days cube strength of concrete.

1717.3 Concrete under acceptance, shall be notionally divided into lots for the purpose of sampling before commencement of work. The basis of delimitation of lots shall be as follows:

- i) No individual lot shall be more than 30 cu.m in volume
- ii) Different grades of mixes of concrete shall be divided into separate lots.
- iii) Concrete of a lot shall be used in the same identifiable component of the bridge.

1717.4 sampling and testing

Concrete for preparing 3 test cubes shall be taken from a batch of concrete at point of delivery for construction, according to procedure laid down in IS:1199.

A random sampling procedure shall be adopted which ensures that each of the concrete batches forming the lot under acceptance inspection has equal chance of being chosen for taking cubes.

150 mm cubes shall be made, cured and tested at the age of 28 days for compressive strength in accordance with IS:516. The 28 day test strength result for each cube shall form an item of the sample. Tests at other age shall also be performed, if specified.

Where automated batching plant/Ready Mixed Concrete Plant is located away from the place of use and the time gap between production and placement is more than the initial setting time or where any ingredients are added subsequent to mixing, separate sets of samples shall be collected and tested at batching plant and at location of placement. The results shall be compared and used to make suitable adjustment at batching plants so that properties of concrete at placement are as per the requirements.

1717.5 test specimen and sample strength

Three test specimens shall be made from each sample for testing at 28 days. Additional cubes may be required for various purposes such as to determine the strength of concrete at 7 days or for any other purpose.

The test strength of the sample shall be the average of the strength of 3 cubes. The individual variation should not be more than ± 15 percent of the average. If variation is more, the test results of the sample are invalid.

1717.6 Frequency

The minimum frequency of sampling of concrete of each grade shall be in accordance with Table 1700-9.

table 1700-9 : Minimum Frequency of sampling

Quantity of Concrete in Work, m ³	no. of samples
1 – 5	1
6 – 15	2
16 – 30	3
31 – 50	4
51 and above	4 plus one additional sample for each additional 50 m ³ or part thereof

At least one sample shall be taken from each shift of work.

1717.7 acceptance criteria

1717.7.1 Compressive strength

1) Cubes

The concrete shall be taken as having the specified compressive strength when both the following conditions are met:

- a) The mean strength determined from any group of four consecutive non-overlapping samples exceeds the specified characteristic compressive strength by 3 MPa.
- b) Strength of any sample is not less than the specified characteristic compressive strength minus 3 MPa.

The quantity of concrete represented by the test results include the batches from which the first and last samples were taken, together with all intervening batches.

2) Cores

When the concrete does not satisfy both the conditions given in (1) above, representative cores shall be extracted from the hardened concrete for compression test in accordance with the method described in IS:1199 and tested to establish whether the concrete satisfies the requirement of compressive strength.

Evaluation of compressive strength by taking cores may also be done in case of doubt regarding the grade of concrete used either due to poor workmanship or based on results of cube strength tests.

The locations from which core samples are to be taken and their number shall be decided so as to be representative of the whole of the concrete under consideration. However, in no case shall fewer than three cores be tested. Cores shall be prepared and tested as described in

IS:516. Concrete in the member represented by a core test shall be considered acceptable if the average equivalent cube strength of the cores is equal to at least 85 percent of the cube strength of the grade of concrete specified for the corresponding age and no individual core has strength less than 75 percent of the specified strength.

1717.7.2 Chloride and sulphate Content

The total chloride and sulphuric anhydride (SO₃) content of all the constituents of concrete as a percentage of mass of cement in the mix, shall not exceed the values given in this Section.

1717.7.3 density of Fresh Concrete

Where minimum density of fresh concrete is specified, the mean of any four consecutive non-overlapping samples shall not be less than the specified value and any individual sample result shall not be less than 97.5 percent of the specified value.

1717.7.4 density of Hardened Concrete

Where minimum density of hardened concrete is specified, the mean of any four consecutive non-overlapping samples shall not be less than the specified value and any individual sample result shall not be less than 97.5 percent of the specified value.

1717.7.5 Permeability test

Water permeability test as per DIN:1048 Part 5–1991 shall be carried out as described below :

- i) A cylindrical test specimen 150 mm dia and 160 mm high shall be prepared.
- ii) After 28 days of curing, the test will be conducted between 28 and 35 days. The test specimen shall be fitted in a machine such that specimen can be subjected to a water pressure of up to 7 bars. A typical machine is shown in Appendix-1700/1.
- iii) The concrete specimen shall be subjected to a water pressure of

0.5 N/mm² from the top for a period of 3 days. The pressure shall be maintained constant throughout the test period. If the water penetrates through to the underside of the specimen, the test may be terminated and the specimen rejected as failed.

- iv) After 3 days, the pressure shall be released and the sample shall be taken out. The specimen shall be split in the middle by compression applied on two round bars on opposite sides above and below.
- v) When the split faces show signs of drying (after 5 to 10 minutes), the maximum depth of penetration in the direction of height shall be measured with the scale and extent of water penetration established.
- vi) The mean of maximum depth of penetration obtained from three specimens thus tested, shall be taken as the test result and it shall not exceed 25 mm.

1717.7.6 If the concrete is not able to meet any of the standards of acceptance as prescribed, the effect of such deficiency on the structure shall be investigated by the Contractor as directed by the Engineer. The Engineer may accept the concrete as sub-standard work. Any additional work required by the Engineer for such acceptance, shall be carried out by the Contractor at his cost. In case the concrete is not found to be acceptable even after investigation, the Contractor shall remove the rejected concrete forthwith.

1717.7.7 When durability of concrete is desired the rapid chloride ion permeability test as stated under Clause 1714.3.1 shall also be performed in addition to above tests.

1718 Measurements For Payment

Structural concrete shall be measured in cubic metres. In reinforced or prestressed concrete, the volume occupied by reinforcement or prestressing cables and sheathing shall not be deducted. The slab shall be measured as running continuously through and the beam as the portion below the slab.

1719 Rate

The contract unit rate for structural concrete shall cover costs of all materials, labour, tools, plant and equipment required for mixing, transporting and placing in position, vibrating and compacting, finishing and curing as per this Section or as directed by the Engineer, including all incidental expenses, sampling and testing, quality assurance and supervision. Unless mentioned separately as an item in the contract, the contract unit rate for concrete shall also include the cost of providing, fixing and removing formwork required for concrete work as per **section 1500** of these Specifications.

If the concrete is found to be acceptable by the Engineer as sub-standard work, the Contractor shall be subjected to reduction in his contact unit rate. For deficiency in compressive strength of concrete when accepted by the Engineer, the reduction in rate shall be applied as under:

$$\text{Percentage reduction in rate} = \frac{\text{Design Strength} - \text{Observed Strength}}{\text{Design Strength}} \times 100$$

2900

PIPE CULVERTS

2901 SCOPE

This work shall consist of furnishing and installing reinforced cement concrete pipes, of the type, diameter and length as per design and details and at locations shown on the drawings or as ordered by the Engineer and in accordance with the requirements of these Specifications.

2902 MATERIALS

All materials used in the construction of pipe culverts shall conform to the requirements of **Section 1000**.

Each consignment of cement concrete pipes shall be inspected, tested, if necessary, and approved by the Engineer either at the place of manufacture or at the site before their incorporation in the works.

2903 EXCAVATION FOR PIPE

The foundation bed for pipe culverts shall be excavated true to the lines and grades shown on the drawings or as directed by the Engineer. The pipes shall be placed in shallow excavation of the natural ground or in open trenches cut in existing embankments, taken down to levels as shown on the drawings. In case of high embankments where the height of fill is more than three times the external diameter of the pipe, the embankment shall first be built to an elevation above the top of the pipe equal to the external diameter of the pipe, and to width on each side of the pipe of not less than five times the diameter of pipe, after which a trench shall be excavated and the pipe shall be laid.

Where trenching is involved, its width on either side of the pipe shall be a minimum of 150 mm or one-fourth of the diameter of the pipe whichever is more and shall not be more than one-third the diameter of the pipe. The sides of the trench shall be as nearly vertical as possible.

The pipe shall be placed where the ground for the foundation is reasonably firm. Installation of pipes under existing bridges or culverts shall be avoided as far as possible. When during excavation the material encountered is soft, spongy or other unstable soil, and unless other special construction methods are called for on the drawings or in special provisions, such unsuitable material shall be removed to such depth, width and length as directed by the Engineer. The excavation shall then be backfilled with approved granular material which shall be properly shaped and thoroughly compacted upto the specified level.

Where bed-rock or boulder strata are encountered, excavation shall be taken down to at least 200 mm below the bottom level of the pipe with prior permission of the Engineer and all rock/boulders in this area be removed and the space filled with approved earth, free from stone or fragmented material, shaped to the requirements and thoroughly compacted to provide adequate support for the pipe.

Trenches shall be kept free from water until the pipes are installed and the joints have hardened.

2904 BEDDING FOR PIPE

The bedding surface shall provide a firm foundation of uniform density throughout the length of the culvert, shall conform to the specified levels and grade, and shall be of one of the following two types as specified on the drawings :

- i) **First Class Bedding** : Under first class bedding, the pipe shall be evenly bedded on a continuous layer of well compacted approved granular material, shaped concentrically to fit the lower part of the pipe exterior for at least ten percent of its overall height or as otherwise shown on the drawings. The bedding material shall be well graded sand or another granular material passing 5.6 mm sieve suitably compacted/rammed. The compacted thickness of the bedding layer shall be as shown on the drawings and in no case shall it be less than 75 mm.
- ii) **Concrete Cradle Bedding** : When indicated on the drawings or directed by the Engineer, the pipe shall be bedded in a cradle constructed of concrete having a mix not leaner than M 15 conforming to Section 1700. The shape and dimensions of the cradle shall be as indicated on the drawings. The pipes shall be laid on the concrete bedding before the concrete has set.

2905 LAYING OF PIPE

No pipe shall be laid in position until the foundation has been approved by the Engineer. Where two or more pipes are to be laid adjacent to each other, they shall be separated by a distance equal to at least half the diameter of the pipe subject to a minimum of 450 mm.

The arrangement for lifting, loading and unloading concrete pipes from factory/yard and at site shall be such that the pipes do not suffer any undue structural strain, any damage due to fall or impact. The arrangement may be got approved by the Engineer.

Similarly, the arrangement for lowering the pipe in the bed shall be got approved by the Engineer. It may be with tripod-pulley arrangement or simply by manual labour in a manner that the pipe is placed in the proper position without damage.

The laying of pipes on the prepared foundation shall start from the outlet and proceed towards the inlet and be completed to the specified lines and grades. In case of use of pipes with bell-mouth, the belled end shall face upstream. The pipes shall be fitted and matched so that when laid in work, they form a culvert with a smooth uniform invert.

Any pipe found defective or damaged during laying shall be removed at the cost of the Contractor.

2906 JOINTING

The pipes shall be jointed either by collar joint or by flush joint. In the former case, the collar shall be of RCC 150 to 200 mm wide and having the same strength as the pipes to be jointed. Caulking space shall be between 13 and 20 mm according to the diameter of the pipe. Caulking material shall be slightly wet mix of cement and sand in the ratio of 1:2 rammed with caulking irons. Before caulking, the collar shall be so placed that its center coincides with the joint and an even annular space is left between the collar and the pipe.

Flush joint may be internal flush joint or external flush joint. In either case, the ends of the pipes shall be specially shaped to form a self centering joint with a jointing space 13 mm wide. The jointing space shall be filled with cement mortar, 1 cement to 2 sand, mixed sufficiently dry to remain in position when forced with a trowel or rammer. Care shall be taken to fill all voids and excess mortar shall be removed.

For jointing pipe lines under light hydraulic pressure, the recess at the end of the pipe shall be filled with jute braiding dipped in hot bitumen or other suitable approved compound. Pipes shall be so jointed that the bitumen ring of one pipe shall set into the recess of the next pipe. The ring shall be thoroughly compressed by jacking or by any other suitable method.

All joints shall be made with care so that their interior surface is smooth and consistent with the interior surface of the pipes. After finishing, the joint shall be kept covered and damp for at least four days.

2907 BACKFILLING

Trenches shall be backfilled immediately after the pipes have been laid and the jointing material has hardened. The backfill soil shall be clean, free from boulders, large roots, excessive amounts of sods or other vegetable matter, and lumps and shall be approved by the Engineer. Backfilling upto 300 mm above the top of the pipe shall be carefully done and the soil thoroughly rammed, tamped or vibrated in layers not exceeding 150 mm, particular

care being taken to thoroughly consolidate the materials under the haunches of the pipe. Approved pneumatic or light mechanical tamping equipment can be used.

Filling of the trench shall be carried out simultaneously on both sides of the pipe in such a manner that unequal pressures do not occur.

In case of high embankment, after filling the trench upto the top of the pipe in the above said manner, a loose fill of a depth equal to external diameter of the pipe shall be placed over the pipe before further layers are added and compacted.

2908 HEADWALLS AND OTHER ANCILLARY WORKS

Headwalls, wing walls, aprons and other ancillary works shall be constructed in accordance with the details shown on the drawings or as directed by the Engineer. Masonry for the walls shall conform to Sections 1300, 1400 or 1700 as applicable. Aprons shall conform to Section 2500.

2909 OPENING TO TRAFFIC

No traffic shall be permitted to cross the pipes unless height of filling above the top of the pipes is at least 600 mm.

2910 MEASUREMENTS FOR PAYMENT

RCC pipe culvert shall be measured as complete work in linear metres along its length between the inlet and outlet ends. Culverts with multiple rows of pipes shall be measured as one unit, irrespective of the number of rows.

2911 RATE

The Contract unit rate for the pipe culvert shall include the cost of pipes including loading, unloading, hauling, handling, storing, laying in position and jointing and all ancillary works such as excavation, bedding for pipes, backfilling, concrete, masonry and aprons and incidental costs to complete the work as per these Specifications.

(B) TECHNICAL SPECIFICATION FOR BUILDING WORKS

SPECIAL CONDITIONS

1.0 General Specifications (Material) :

- 1.1 The quoted rates for various items in the tender shall be inclusive of all terms and conditions such as additional conditions, special conditions, particular specifications etc. and for adherence to all terms, conditions and specifications mentioned in the tender document. No extra payment shall be made to the contractor on account of this. Any infringement and/or breach of these specification and condition(s) etc. shall render the contractor liable for action(s) under various clauses of the contract and such action stipulated in conditions therein.
- 1.2 GST Building and other Construction workers Welfare Cess or any other tax or cess in respect of this contract shall be payable by the contractor and **JIADA** shall not entertain any claim whatsoever in this respect.
- 1.3. The Contractor shall make his own arrangements for electricity required for the execution of the work. Necessary payment shall be made by the Contractor directly to the department concerned. In case the statutory authority fails to sanction the electric connection or delays the sanction of electric connection, the Contractor shall make his own arrangements by providing diesel generators of adequate capacity at his own cost. No delay on this account shall be accepted. Nothing extra shall be paid on this account.
- 1.4. The Contractor shall make his own arrangement for backup power at his own cost. No interruption of work shall be accepted due to power failure. Nothing extra shall be paid on this account.
- 1.5. No walls or terraces shall be cut for making any opening after water proofing has been done without written approval of Engineer-in-Charge. When permitted, cutting of water proofing work shall be done very carefully so that other portion of water proofing is not damaged. On completion of work at such place the water proofing work shall be made good and ensured that the opening / cutting is made fully water proof as per contract specifications/ directions of Engineer-in-Charge. Nothing extra shall be payable on this account.
- 1.6. No structural member shall be chased or cut without the written permission of the Engineer-in-Charge.
- 1.7. Material and methods of construction for all civil works shall be as per relevant Indian Standard Specification part of which are incorporated in Indian the standard specification of the CPWD and PWD Jharkhand and will be followed during the execution of the work. The work shall be executed as per the guidelines and provision of BIS All material shall be confirm to Indian Standard

Code of practice non and Building code and CPWD works manual to maintain quality of work.

A references made to any Indian Standard Specifications in these documents, shall imply to the latest version of that standard, including such revisions / amendments as issued by the Bureau of Indian Standards upto last date of receipt of tenders. The contractor shall keep at his own cost all such publications of relevant Indian Standard applicable to the work at site.

Decision of Engineer-in-charge shall be final and binding.

- 1.8. The Contractor shall be bound to follow the instructions and restrictions imposed by the Local Administration / Police authorities on the working and /or movement of labour, materials etc. and or due to less/ restricted working hours or any detours in movement of vehicles. Nothing extra shall be payable on this account.
- 1.9. The Contractor shall take all precautions to avoid accidents by exhibiting necessary caution boards such as day and night boards, speed limit boards and flags, red lights and providing barriers, etc. He shall be responsible for all damages and accidents caused due to negligence on his part. No hindrance shall be caused to traffic during the execution of work. Nothing extra shall be payable on this account.
- 1.10. All material shall only be brought at site as per programme finalized with the respective Engineer-In-Charge. Any pre-delivery of the material, not required for immediate consumption shall not be accepted and thus not paid for.
- 1.11. Large scale details and manufacture's dimensions for material to be incorporated shall take precedence over small scale drawings.
- 1.12. No foreign exchange shall be made available by the **JIADA** for the purchase of equipments, plants, machinery, material of any kind or other items required to be carried out in execution of work .
- 1.13. In accordance with requirements of the pollution control board, the contractor shall ensure that, the vehicles for bringing construction material to the site shall be in good condition and should conform to applicable air and noise emission standards and should be operated only during non-peak hours/ at such hours as are permitted by the local authorities. Nothing extra shall be payable on this account.
- 1.14. In accordance with requirements of the pollution control board, the contractor shall ensure that, ambient noise levels should conform to residential standards both during day and night. Incremental pollution loads on the ambient air and noise quality should be closely monitored during construction phase. Nothing extra shall be payable on this account.
- 1.15. In accordance with requirements of the pollution control board, the contractor shall ensure that, adequate measures to reduce air and noise pollution during construction have been adopted as per CPCB norms on noise limits. Nothing extra shall be payable on this account.

- 1.16. In accordance with requirements of the pollution control board, the contractor shall ensure that, the temporary roads inside the site must be sprinkled with water to control the dust arising due to movement of vehicles. Nothing extra shall be payable on this account.
- 1.17. Construction spoils, including bituminous material and other hazardous materials, must not be allowed to contaminate watercourses and the dump sites for such material must be secured so that they should not leach into the ground water. Nothing extra shall be payable on this account.
- 1.18. In accordance with requirements of the pollution control board, the DG sets installed during construction activity must be provided with necessary acoustic measures and exhaust pipe above the height of nearest tall building. Nothing extra shall be payable on this account.
- 1.19. In accordance with requirements of the pollution control board, the diesel generator sets to be used during construction phase shall be low sulphur diesel type and shall conform to E(P) Rules prescribed for air and noise emission standards. Nothing extra shall be payable on this account.
- 1.20. In accordance with requirements of the pollution control board, the safety equipments like boots, helmets, safety belts, gloves etc. must be provided for the workers and best and safe engineering practices must be adopted. Nothing extra shall be payable on this account.
- 1.21. In accordance with requirements of the pollution control board, the stipulations under the provisions of Water(Prevention and Control of Pollution) Act, 1974, the Air (Prevention and control of Pollution) Act 1981, the Environment (Protection) Act, 1986, the Public Liability (Insurance) Act,1991 and EIA Notification, 2006 shall be ensured. Nothing extra shall be payable on this account.
- 1.22. If, any levy / fine is imposed by the regulatory authorities / inspecting authorities on account of violation of the above specified norms, the same shall be recovered from the contractor.
- 1.23. Except for the items, for which Particular Specifications are given or where it is specifically mentioned otherwise in the description of the items in the schedule of quantities, the work shall generally be carried out in accordance with the "Indian Standard Specification of CPWD and PWD Jharkhand" and as per instructions of Engineer-in-Charge. Wherever Indian Standard Specification of CPWD and PWD Jharkhand Specifications are silent, the latest IS Codes / Specifications shall be followed and the rates should be all inclusive.
- 1.24. Any reference made to any Indian Standard Specifications, shall imply to the latest version of that standard, including such revisions / amendments as issued by the Bureau of Indian Standards up to last date of receipt of tenders. The Contractor shall keep at his own cost all such publications including relevant Indian Standard applicable to the work at site.

- 1.25 The work shall be executed and measured as per metric dimensions given in the Schedule of Quantities, drawings etc. (FPS units wherever indicated are for guidelines only).
- 1.26 The work should be planned in a systematic manner so that chase cuttings in the walls, ceilings and floors is minimized. Wherever absolutely essential, the chase shall be cut using chase cutting machines. Chases will not be allowed to be cut using hammer / chisel. The electrical boxes should be fixed in walls simultaneously while raising the brick work. The contractor shall ensure proper co-ordination of various disciplines viz. sanitary & water supply, horticulture & electrical etc.
- 1.27 All the hidden items such as water supply lines, drainage pipes, conduits, sewers etc. are to be properly tested before covering.
- 1.28 Samples including brand / quality of materials and fittings to be used in the work shall be got approved from the Engineer-in-Charge, well in advance of actual execution and shall be preserved till the completion of the work.
- 1.29 Equipment like concrete pump excavators/Transit mixer etc. shall be allowed to be moved away from the site when, in written opinion of Engineer-in-Charge, the same are no longer required at site of work.
- 1.30 The contractor, his agents / representative, workman etc. shall strictly observe orders pertaining to fire precautions prevailing in the area.
- 1.31 Contractor(s) shall study the soil investigation report for the site, available in the office of the Engineer-in-Charge and satisfy himself about complete characteristics of soil and other parameters at site. However, no claim on the alleged inadequacy or incorrectness of the soil data supplied by the department shall be entertained.
- 1.32 The tenderer shall see the approaches to the site. In case any approach from main road is required at site or existing approach is to be improved and maintained for cartage of materials by the contractor, the same shall be provided, improved and maintained by the contractor at his own cost.
- 1.33 Contractor shall take all precautionary measures to avoid any damage to adjoining property. All necessary arrangement shall be made at his own cost.
- 1.34 The contractor shall take all precautions to avoid accidents by exhibiting necessary caution boards day and night, speed limit boards, red flags, red lights and providing barriers. He shall be responsible for all damages and accidents caused to work due to negligence on his part. No hindrances shall be caused to traffic, during the execution of the work.
- 1.35 The contractor shall take instructions from the Engineer-in-Charge regarding collection and stacking of materials at any place. No excavated earth or building rubbish shall be stacked on areas where other buildings, roads, compound wall, services etc are to be constructed.
- 1.36 The contractor shall provide at his own cost suitable weighing, surveying and leveling and measuring arrangements as may be necessary at site for checking. All such equipments shall be got calibrated in advance from

laboratory, approved by the Engineer-in-Charge. Nothing extra shall be payable on this account.

- 1.37 Contractor shall provide permanent bench marks, flag tops and other reference points for the proper execution of work and these shall be preserved till the end of work. All such reference points shall be in relation to the levels and locations, given in the Architectural and plumbing drawings.
- 1.38 Water tanks, taps, sanitary, water supply and drainage pipes, fittings and accessories should conform to byelaws and municipal body / corporation where Indian Standard Specification of CPWD and PWD Jharkhand Specifications are not applicable. The contractor should get the materials (fixtures/fittings) tested by the Municipal Body / Corporation authorities wherever required at his own cost.
- 1.39 The work shall be carried out in accordance with the Architectural drawings and Structural drawings, to be issued from time to time, by the Engineer-in-Charge. Before commencement of any item of work, the contractor shall correlate all the relevant architectural and structural drawings issued for the work, nomenclature of items, specifications etc. and satisfy himself that the information available there from is complete and unambiguous. The figures & the written dimensions of the drawing shall supersede the measurement by scale. The discrepancy, if any, shall be brought to the notice of the Engineer-in-Charge for immediate decision before execution of the work. The contractor alone shall be responsible for any loss or damage occurring by the commencement of work on the basis of any erroneous and/ or incomplete information and no claim, whatsoever shall be entertained on this account.
- 1.40 The Architectural drawings other than those indicated in nomenclature of items are only indicative of the nature of the work and materials/fittings involved unless and otherwise specifically mentioned.
- 1.41 The contractor should submit the shop drawing of staging and shuttering for approval of Engineer-in-Charge before actually commencing the execution of work under the item. Nothing extra shall be payable on this account.
- 1.42 Other agencies may also simultaneously execute and install the works and the contractor shall afford necessary facilities for the same. The contractor shall leave such recesses, holes, openings, trenches etc. as may be required for such related works (for which inserts, sleeves, brackets, conduits, base plates, clamps etc. shall be available as specified elsewhere in the contract) and the contractor shall fix the same at the time of casting of concrete, stone work and brick work, if required, and nothing extra shall be payable on this account.
- 1.43 The contractor shall conduct his work, so as not to interfere with or hinder the progress or completion of the work being performed by other contractor(s) or by the Engineer-in-Charge and shall as far as possible arrange his work and shall place and dispose of the materials being used or removed so as not to interfere with the operations of other contractor or he shall arrange his work with that of the others in an acceptable and coordinated

manner and shall perform it in proper sequence to the complete satisfaction of others.

- 1.44 All material shall only be brought at site as per program finalized with the Engineer-in-Charge. Any pre-delivery of the material not required for immediate consumption shall not be accepted and thus not paid for.
- 1.45 The contractor shall procure the required materials in advance so that there is sufficient time for testing of the materials and approval of the same before use in the work.
- 1.46 Existing drains, pipes, cables, over-head wires, sewer lines, water lines and similar services encountered in the course of the execution of work shall be protected against the damage by the contractor at his own expense. The contractor shall not store materials or otherwise occupy any part of the site in a manner likely to hinder the operation of such services. In case temporary supporting/shifting of such services is required to facilitate the work, the same shall be done by the contractor at no extra cost.
In case the existing services are to be shifted permanently, then before dismantling the existing services, alternate/diversion of service lines has to be laid by the contractor so that there is no interruption in use of existing services. The contractor has to plan the alternate suitable route for diversion/shifting of service lines and get the same approved from the Engineer-in-Charge before starting shifting of services. Nothing extra shall be paid except the payment of dismantling and laying of new service lines as per conditions of contract.
- 1.47 The contractor shall be responsible for the watch and ward / guard of the buildings, safety of all fittings and fixtures including sanitary and water supply fittings and fixtures provided by him against pilferage and breakage during the period of installations and thereafter till the building is physically handed over to the department. No extra payment shall be made on this account.
- 1.48 The contractor shall be fully responsible for the safe custody of materials brought by him/ issued to him even though the materials may be under double lock key system.
- 1.49 For construction works which are likely to generate malba / rubbish to the tune of more than a tempo / truck load, contractor shall dispose of malba, rubbish & other unserviceable materials and wastes at his own cost to the notified /specified dumping ground and under no circumstances these shall be stacked / dumped even temporarily, outside the construction premises.
- 1.50 Surplus excavated earth which is beyond the requirement of the **JIADA** shall have to be disposed of the contractor at his own cost beyond the municipal limits or at places identified by the local bodies or as directed by the Engineer-in-Charge after obtaining written permission of the Engineer-in-Charge and no payment will be made by the Department for such disposal of this surplus excavated earth.

- 1.51 The work is to be carried out in the compound where free movement of contractor's vehicle and labour may be restricted. The contractor has to follow the security requirement of campus area viz. entry passes for the labour and vehicles, security checks at entry/ exit gates, restriction on movement of vehicles, restricted timings of working etc. The **JIADA** however shall assist the contractor in obtaining such passes for movement of vehicles and labour. No claim whatsoever shall be entertained on account of delay in entry of vehicles and labour in the campus area including restrictions in working hours, if there is any.
- 1.52 Communication and commuting:
In order to maintain instant and effective communication at all times, the contractor shall provide one set of communication system to the site so as to receive and pass on the instructions to and from the staff of department/ contractor irrespective their place and location. The rates quoted by the contractor shall be deemed to be inclusive of this cost. No additional payment shall be made to the contractor for providing these facilities.
- 1.53 The contractor shall take all precautions to avoid accidents by exhibiting necessary caution boards day and night, speed limit boards, red flags, red lights and providing barriers. He shall be responsible for all damages and accidents caused to work due to negligence on his part. No hindrances shall be caused to traffic, during the execution of the work.
- 1.54 With each Running Bill, the details of test carried out shall be submitted by the contractor as per perform given in the document.
- 1.55 On completion of work, the contractor shall submit at his own cost four prints of "as built" drawings to the Engineer-in-Charge. These drawings shall have the following information.
- a) Run off of all piping and their diameters including soil, waste pipes and vertical stacks.
 - b) Ground and invert level of all drainage pipes together with locations of all manholes and connections, upto out fall.
 - c) Run off of all water supply lines with diameters, location of control valves, access panels etc. In case the contractor fails to supply "as built drawing" aforesaid within 30 days of the date of completion, then the recovery @ Rs.10, 000/- each for such set of drawings shall be made from the contractor's final bill.
- 1.56 In the item of providing and fixing precast reinforced cement concrete in shelves the cost of cutting chases and making good the same shall be inclusive in the item and nothing extra shall be paid on this account.
- 1.57 In the item of finishing walls with exterior paint, only the plain/flat area shall be measured for payment and nothing extra shall be paid on account of pointed wall surface.

2.0 Rates:

Unless otherwise specified in the schedule of quantities, the rates for respective items shall be all inclusive and apply to the following: -

- (i) All lifts & all heights, floors including terrace, leads and depths.
- (ii) All labour, material, tools and plants and other inputs involved in the execution of the item.
- (iii) Any of the conditions and specifications mentioned in the tender documents.
- (iv) Pumping / bailing out surface water / rain water / sub soil water, if necessary for any reason.
- (v) Providing sunk flooring in bath-rooms, kitchen, etc.
- (vi) Any legal or financial implications resulting out of disposal of earth, unserviceable building materials, debris, malba, if any.
- (vii) Payment of Royalty at the prevailing rates, if any, on the boulders, metal, shingle, sand and bajri etc. or any other material collected by him for the work direct to revenue authorities.
- (viii) Performance test of the entire installation(s) before the work is finally accepted.
- (ix) Any cement slurry added over base surface (or) for continuation of concreting for better bond is deemed to have been built in the items.
- (x) All incidental charges for cartage, storage and safe custody of materials brought to site.

3.0 SECRECY

- 3.1 The contractor shall take all steps necessary that all persons employed on any work in connection with the contract have notice that the Indian Official Secrets Act 1923 applies to them & will continue so to apply even after the execution of such works under the contract.
- 3.2 The contract is confidential and must be strictly confined to the contractor's own use (except so far as confidential disclosure to sub-contractors or suppliers as necessary) and to the purpose of the contract.
- 3.3 All documents, copies thereof & extracts there from furnished to the contractor shall be returned to the Engineer-in-Charge on the completion of the work / works or the earlier determination of the contract.

4.0 LABOUR AND SECURITY

- 4.1 The contractor shall employ only Indian Nationals after verifying their antecedents and loyalty. The contractor shall, on demand submit list of his agents, employees and work people concerned & shall satisfy as to the bonafides of such people.
- 4.2 The contractor & his work people shall observe all relevant rules regarding security promulgated in which work is to be carried out by the Controlling Administrative Authority of the IISER campus/area (hereinafter referred to as "Administrator").
- 4.3 The contractor, his representative, workman shall be allowed to enter through specified gates & timing as laid down by the controlling authority.

They shall be issued an identity card or an individual pass in accordance with the standing rules & regulations & they should possess the same while working. The contractor shall be responsible for the conduct & actions of his workman, agents / representatives.

- 4.4 Normally contractor shall be allowed to carryout work between 7 AM to 6 PM. However, he may also be allowed to carryout the work beyond 6 PM & up to 7 AM if the site conditions / circumstances so demand with prior written permission from the "Administrator". However, if the work is carried out in more than one shift or at night, no claim on this account shall be entertained.
- 4.5 Normally contractor's material / vehicles etc shall be allowed to move in / go-out between 7 AM to 7 PM only & no movement of material / vehicles out of site of work shall be allowed during night hours unless specific permission is obtained from the "Administrator".
- 4.6 In case if a separate entry has been allowed, the contractor has to make all arrangement for making a separate entry gate and barricading of the working area to segregate/separate the same from other areas. All these have to be done by the contractor at his own cost including safeguarding any untoward incident in the restricted area due to separate entry gate and barricading arranged by the contractor. No extra amount on this account shall be payable by the department.
- 5.0 **PROGRAM CHART:** -
- 5.1 The Contractor shall prepare an integrated program chart for the execution of work, showing clearly all activities from the start of work to completion, with details of manpower, equipment and machinery required for the fulfillment of the program within the stipulated period or earlier and submit the same for approval of the Engineer-in-Charge within 15 days of the issue of letter of acceptance for the contract.
- 5.2 The work has to be completed in stages as indicated in the Milestones under clause 5 and the program should be prepared in such a manner to achieve these Milestones as indicated therein or even earlier.
- 5.3 The program chart should include the following: -
 - a) Descriptive note explaining sequence of various activities.
 - b) Network (PERT / CPM / BAR CHART) which will indicate resources in financial terms, manpower and specialized equipment for every important stage.
 - c) Program for procurement of materials by the contractor.
 - d) Program of procurement of machinery / equipments having adequate capacity, commensurate with the quantum of work to be done within the stipulated period, by the contractor.
- 5.4 If at any time, it appears to the Engineer-in-Charge that the actual progress of work does not conform to the approved program referred above, the contractor shall produce a revised program showing the modifications to the approved program by additional inputs to ensure completion of the work within the stipulated time.

- 5.5 The submission of revised program or approval by the Engineer-in-Charge of such program or the furnishing of such particulars shall not relieve the contractor of any of his duties or responsibilities under the contract. This is without prejudice to the right of Engineer-in-Charge to take action against the contractor as per terms and conditions of the agreement.
Notwithstanding the fact that the contractor will have to pay to the labourers and other staff engaged directly or indirectly on the work according to the provisions of the labour regulations and the agreement entered upon and/or extra amounts for any other reason.

6.0 PROGRESS AND MONITORING OF WORK:

Contractor shall give the Engineer-in-Charge on the 10th day of each month, progress report of the work done during the previous month. Such progress report will include the project progress summary, work progress (planned v/s. actual), PERT chart, milestone status, financial progress status, manpower deployment status, important materials consumed, materials at site at the beginning of the month, materials consumed during the month and the balance quantities at the end of month and progress of the work stating the reasons for shortfall, if any including the steps and measures to be taken for making good the shortfall in the succeeding period. Non submission of aforesaid progress report shall make contractor liable for action under breach of contract conditions.

7.0 SAMPLE OF MATERIALS:-

- 7.1 All materials and fittings brought by the contractor to the site for use shall conform to the samples approved by the Engineer-in-Charge which shall be preserved till the completion of the work. If a particular brand of material is specified in the item of work in Schedule of Quantity, the same shall be used after getting the same approved from Engineer-in-Charge. Wherever brand / quality of material is not specified in the item of work, the contractor shall submit the samples as per **List of Preferred Makes stated in the document** for approval of Engineer-in-Charge. For all items, ISI Marked materials and fittings shall be used with the approval of Engineer-in-Charge. Wherever ISI Marked material / fittings are not available, the contractor shall submit samples of materials / fittings manufactured by firms of repute conforming to relevant Specifications or IS codes for the approval of Engineer-in-Charge.
- 7.2 To avoid delay, contractor should submit samples as stated above well in advance so as to give timely orders for procurement. If any material, even though approved by Engineer-in-Charge is found defective or not conforming to specifications shall be replaced / removed by the contractor at his own risk & cost.
- 7.3. BIS marked materials, except otherwise specified, shall also be subjected to quality test besides testing of other materials as per the specifications described for the item/material. Wherever BIS marked materials are brought to the site of work, the contractor shall, furnish manufacturer's test certificate or test certificate from approved testing laboratory to establish that the material procured by the contractor for incorporation in the work

satisfies the provisions of specifications relevant to the material and / or the work done.

BIS marked items (except cement & steel for which separate provisions have been made in para 10.0) required on the work shall be got tested, for only important tests, which govern the quality of the product, as decided by the Engineer-in-Charge. For mandatory test, frequency shall be as specified in Indian Standard Specification of CPWD and PWD Jharkhand Specifications.

- 7.4 For certain items, if frequency of tests is neither mentioned in the Indian Standard Specification of CPWD and PWD Jharkhand Specifications & BIS, then tests shall be carried out as per decision of Engineer-in-Charge.

8.0 CEMENT & STEEL REINFORCEMENT

- 8.1 Contractor has to produce manufacturers test certificate for each lot of Cement & Steel Reinforcement procured at site.

8.2 CEMENT:-

- 8.2.1 The contractor shall procure Ordinary Portland cement conforming to relevant BIS Code, as required in the work, from reputed manufacturers of cement having a production capacity of one million tonnes per annum or more such as Ambuja, A.C.C., Ultratech, Vikram, Shri Cement, Reliance, Lafarge etc. as approved by Ministry of Industry, Govt of India, holding license to use ISI certification mark for their product. If cement of any other manufacturer is used the same shall be got approved from the Engineer-in-Charge. Supply of cement shall be taken in 50 kg bags bearing manufacture's name and ISI marking, along with manufacturers test certificate for each lot of cement. Samples of cement arranged by the contractor shall be taken by the Engineer-in-Charge and got tested in accordance with provisions of the relevant BIS codes. In case test results indicate that the cement arranged by the contractor does not conform to the relevant BIS codes, the same shall stand rejected and shall be removed from the site by the contractor at his own cost within a week's time of written order from the Engineer-in-Charge to do so.

- 8.2.2 The Cement shall be brought at site in quantity of lots as decided by the Engineer-in-Charge. Cement bags shall be stored in separate godowns. Separate godowns for tested cement and fresh cement (under testing) to be constructed by the contractor at his own cost as per sketches given in C.P.W.D Specifications having weather-proof roofs and walls. The size of the cement godown is indicated in the sketches for guidance. The actual size of godown shall be as per site requirements and nothing extra shall be paid for the same. Double lock provision shall be made to the door of the cement godown. The keys of one lock shall remain with the Engineer-in-Charge or his authorised representative and the key of other lock shall remain with the contractor. The contractor shall facilitate the inspection of the cement godown by the Engineer-in-Charge at any time.

8.2.3 The contractor shall supply free of charge the cement required for testing.
The

cost of tests

shall be borne by the contractor/ Department in the manner indicated below:

- i. By the contractor, if the results show that the cement does not conform to relevant BIS codes.
- ii. By the Department, if the results show that the cement conforms to relevant BIS codes.

8.2.3 If the quantity of cement actually used in the work is found to be more than the theoretical quantity of cement including authorized variation, nothing extra shall be payable to the contractor on this account. In the event of it being discovered that after the completion of the work, the quantity of cement used is less than the quantity ascertained as herein before provided (allowing variation on the minus side as stipulated in Clause - 42), the cost of quantity of cement not so used shall be recovered from the contractor as specified in schedule. Decision of the Engineer-in-Charge in regard to theoretical quantity of cement which should have been actually used as per the schedule and recovered at the rate specified, shall be final and binding on the contractor.

For non-scheduled items, the decision of the Superintending Engineer regarding theoretical quantity of the cement, which should have been actually used, shall be final and binding on the contractor.

8.2.4 In case the contractor brings surplus quantity of cement the same shall be removed from the site after completion of work by the contractor at his own cost after approval of the Engineer-in-Charge.

8.3 STEEL REINFORCEMENT: -

8.3.1 The contractor shall procure TMT steel reinforcement bars confirming to **relevant BIS codes** from approved **Primary producers** having BIS License to produce TMT bars as per list of preferred makes stated in the document only / as specified in schedule -F. The documents in support of the purchase of steel shall be produced by the contractor along with the particulars of the manufacturer/supplier of steel and test report for every lot of steel. The contractor shall obtain Original Vouchers and Test Certificates and furnish the same to the Engineer-in-Charge in respect of all the lots of steel brought by him from approved supplier to the site of work. The original vouchers and test certificates shall be defaced by the Site staff and kept on record in the site office

8.3.2 The steel reinforcement shall be brought to the site in quantity of lots as approved by the Engineer-in-charge along with manufacturer test certificate for each lot.

8.3.3 The steel reinforcement shall be stored by the contractor at site of work about 30cm. to 45 cm. above ground in such way as to prevent distortion and corrosion. A coat of cement wash shall be given to steel bars when stored at site for long duration so as to prevent corrosion. Nothing extra shall be paid on these accounts. Bars of different sizes and lengths shall be stored separately to facilitate easy counting and checking.

- 8.3.4 In case the contractor bring surplus quantity of steel, the same after completion of the work will be removed from the site by the contractor at his own cost after approval of the Engineer-in- Charge. Nothing shall be paid on this account.
- 8.3.5 Reinforcement including authorised spacer bars and lap pages shall be measured in length of different diameters as actually (not more than as specified in the drawings) used in the work nearest to a centimeter. Wastage and unauthorized overlaps shall not be measured.
- 8.3.6 Samples of steel reinforcement of each diameter shall also be taken and got tested by Engineer-in-Charge as per the provisions in this regard in the relevant BIS codes. In case test results indicate that the steel arranged by the contractor does not conform to the BIS codes, the same shall stand rejected and shall be removed from the site by the contractor at his own cost within a week's time of written order from the Engineer-in-Charge to do so.
- 8.3.7 For steel procured from main producers or secondary producer, for checking nominal mass, tensile strength, bend test, etc. specimen of sufficient length shall be cut from each diameter of the bar at random at frequency not less than that specified below. In case of works costing more than Rs. 2 Crores and when the steel is procured from other than main producers, additional tests such as, retest, re-bend test, elongation test, proof stress may also be conducted.

Size (Diameter) of bar	For consignment	
	Below 100 tones	Over 100 tones
Under 10m dia.	One sample for each 25 tones or part thereof	One sample for each 40 tones or part thereof
10mm to 16 mm dia.	One sample for each 35 tones or part thereof	One sample for each 45 tones or part thereof
Over 16mm dia	One sample for each 45 tones or part thereof	One sample for each 50 tones or part thereof

- 8.3.8 The contractor shall supply free of charge the steel bars required for testing. The cost of tests shall be borne by the contractor/ Department in the manner indicated below:
- By the contractor, if the results show that the steel does not conform to relevant BIS codes.
 - By the Department, if the results show that the steel conforms to relevant BIS codes.
- 8.3.9 Coefficient of weight i.e. the weight per unit length of the steel procured by the contractor shall be ascertained at site before using it and certified by the Engineer-in-charge. In case weight per unit length is beyond the rolling margin as laid down in the BIS: 1786, the steel will be rejected and shall be removed from the site of work within; a week's time from written order from the Engineer-in - Charge to do so. In case weight per unit length is more than the standard coefficient of weight for the diameter, but is within the rolling margin, then the payment shall be made as per the standard weight per unit length, and, where the weight per unit length is lesser than the standard

coefficient of weight for the diameter, but is within the rolling margin, the payment shall be restricted with respect to the actual weight per unit length of the diameter.

8.3.10 The standard sectional weights referred to in standard table under para 5.3.3, page 75 of the revised CPWD specifications 2002 and PWD, Jharkhand for cement mortar, cement Concrete and RCC works, are to be considered for conversion of length of various sizes of Steel Reinforcement bars into weight and are reproduced below ready reference.

Size (mm)	Weight (Kg/M)	Size (mm)	Weight(Kg/M)
6	0.222	20	2.470
8	0.395	22	2.980
10	0.617	25	3.850
12	0.888	28	4.830
16	1.580	32	6.310
18	2.000	36	7.990

8.4 Steel and Cement brought to site and remaining unused shall not be removed from site without written permission of the Engineer-in-charge.

8.6 Cement used in ready mix concrete shall be evaluated based on the certification by the in-charge of the RMC plant in accordance with design approved by the Engineer in-charge.

9.0

10.1 Some restrictions may be imposed by the Statutory Authority etc. on the working and/ or movement of labour, materials etc. and the contractor shall be bound to follow all such restrictions/ instructions and nothing extra shall be payable on this account.

10.2 The contractor shall comply with proper and legal orders and directions of the local or public authority or municipality and abide by their rules and regulations and pay all fees and charges which he may be liable and nothing extra shall be payable on this account. The work shall be carried out without infringing on any of the local Municipal Bye-Laws.

10.3 The rate for every item of work to be done under this contract shall be for all heights, depths, lengths and widths of the structure (except where specially mentioned in the item) and nothing extra will be paid on this account.

10.4 The contractor shall take all precautions to avoid all accidents by exhibiting necessary caution boards such as day and night boards, speed limit boards and flags, red lights and providing barriers etc. He shall be responsible for all damages and accidents caused due to negligence on his part. No hindrance shall be caused to traffic during the execution of work. Nothing extra shall be paid on this account.

10.5 The contractor will work in close liaison, during the works, with other contractors of water supply, sanitary, drainage arrangements, electrical installation and any other works and adjust his work plan accordingly.

11. Stone Aggregate :-

Stone aggregate used in the work shall be of hard broken stone to be obtained from approved source and shall conform to the relevant provisions in the C.P.W.D. Specifications 2009 (vol -I) as mentioned in Para (I) above.

12. Coarse Sand :-

Coarse sand used in the work shall be obtained from approved sources and conform to the relevant provisions in the C.P.W.D. Specifications 2009, Vol. I as mentioned in Para -I (1) above as per grading zone - III in case of RCC Work & Brick Work and grading zone-IV for plastering.

13. Fine Sand :-

Fine sand used in the work shall be obtained from approved sources and shall conform to the relevant provisions in the C.P.W.D. Specifications 2009 (vol. I) as mentioned in Para I (1) above as per grading zone IV. In case sand available at above source does not conform to the required specifications coarse sand shall be fixed in it to the required specifications. Nothing extra shall however be paid for it.

NOTE :-

Where only one variety of sand is available, the sand will be sieved for use in finishing work, as directed by the Engineer-in-charge, in order to obtain smooth surface and nothing extra will be paid on this account.

14. Brick Work :-

Brick used in the work shall be FPS to be obtained from approved sources. They shall be well burnt and shall have a compressive strength of not less than **50 Kgs./ Sq. cm.** And water absorption percentage of not more than 20% of its dry weight when immersed in the water for 24 hours. In all other respects they shall conform to the bricks of class designations provisions in C.P.W.D. Specifications for works 2009 (Vol.-I) with up to date correction slip.

15. Other Taxes and Royalties

15.1 **Income Tax and surcharges over Income Tax etc.** at the rates fixed by the Ministry of finance, Government of India, shall be deducted from all the running and final bills of the contractor. Should there be any increase in rate of Income Tax and surcharge during execution of the contract, the same shall be payable by the contractor.

15.2 **Royalty** shall have to be paid by the contractor on all materials such as stone, bricks, boulders, metal, shingle, bajri, stone aggregate, coarse sand and fine sand etc. or any other materials used for the execution of the work direct to the Revenue Authority of the District/State Govt. concerned. The contractor shall obtain "No Demand" certificate from the District/State Govt. authority concerned before the final bill is paid, failing which necessary recovery will be effected at the applicable rates in the final bill.

16.0 ENGAGING SPECIALISED AGENCIES FOR WORKS: -

16.1 The Contractor shall engage specialized agency unless otherwise approved by any Government Department having adequate technical capability and experience of having executed at least one work of similar items of 80% or more magnitude or two works of similar items of minimum 60% magnitude or three works of similar items of minimum 40% magnitude individually for executing the following items of the work and/or any other items of work where specialized firm is required to be engaged as per contract conditions. For determining the required magnitude, the value of the work executed may be suitably enhanced with the prevailing approved cost index.

- i) Water proofing treatment work of all types
- ii) Fabrication and erection of steel truss ,
- iii) False ceiling , wall paneling and Furnishing of auditorium
- iv) Tube well
- v) Road work

16.2 The Specialized agency for the work shall be got approved from the Engineer-in-Charge well before actual commencement of the item of work. The contractor shall submit the list of Specialized agencies, proposed to be engaged by him along with necessary performance certificates, within 15 days from the date of issue of acceptance letter to substantiate technical capability and experience of the agency for prior approval of the Engineer-in-Charge.

16.3 The conditions of approval of specialized agency shall be final and binding on the contractor and he shall comply with such conditions of approval.

17.0 **QUALITY ASSURANCE & QUALITY CONTROL**

17.1. The work shall be subjected to a strict quality assurance and quality control as prescribed in the tender documents and as may be further required by the Engineer-in-charge.

17.2. The Contractor shall be required to carry out all mandatory tests as per the Indian Standard Specification of CPWD and PWD Jharkhand Specifications and other tests prescribed in this tender document. In addition, the Engineer-in-charge may at his discretion, order carrying out additional tests, as may be felt necessary by him.

17.3. Tests shall be carried out from one of the following laboratories/test houses as shall be decided by the Engineer in- charge.

- (i) National Test issue, Kolkata.
- (ii) Shri Ram Institute for Industrial Research, New Delhi.
- (iii) NABL accredited labs.
- (iv) Any Government Technical Institute

17.4 The agency shall essentially deploy equipment & machinery (owned or hired) as per the list given the document, in addition to any other T & P required to achieve the Milestone(s) at his own cost.

Name of work:

List of Preferred Makes for Civil & Public Health Works		
S. No.	Name of Materials	Preferred Makes
1	Cement (OPC)	Ambuja, A.C.C., Ultratech, Shri Cement, Jaypee etc.
2	White Cement	Birla White / J. K. White
3	Reinforcement Steel	Primary producer- SAIL / TATA Steel / RINL
4	Commercial Board	Greenply/Century

5	Laminated Particle Board	Greenply/ Century
6	Flush Door Shutters	Century / ALPRO / NATIONAL
7	Water Proofing Compound	Fosroc / Pidilite / Sika
8	PVC Pipe & Fittings	Supreme / Finolex / Prince
9	Acrylic smooth exterior paint / Plastic Emulsion Paint / OBD	ICI / Asian Paints/Nerolac
10	Synthetic Enamel Paint	ICI / Asian Paints / Nerolac
11	Steel Primer	ICI / Asian Paints/ Nerolac
12	Wood Primer	ICI / Asian Paints/ Nerolac
13	Nuts / Bolts & Screws	GKW / Atul
14	Stainless Steel Sink (Out of Salem Steel only)	NIRALI / Jayna
15	Float Valve	Viking / Prayag.
16	Vitreous China Sanitary Ware	Parryware / Hindware / Cera
17	Plastic Seat Cover of W.C. (ISI Mark only)	Hindware / Admiral / Parryware / Cera
18	CP Fittings / Mixer Pillar taps Washers	ESSCO/ESS-ESS / Marc / Orient
19	CP Accessories	ESSCO/ ESS-ESS / Marc / Orient
21	G.I. Pipes	Jindal / TATA/BANSAL
22	G.I. Fittings	Unik / UU
23	Gun metal Valves	Leader / Zoloto / Sant
24	Mirror Glass	Modi Guard / Saint Gobain
25	Aluminum Sections	Jindal / Hindalco
26	Aluminum Fittings	Classic / Everite
27	6 mm / 12 mm thick Ply	Century / Green ply
28	Ceramic Glazed Tiles (Matt Finish)	Johnson / Kajaria
29	Glazed Vitrified Tiles Rectified (Pure Matt Finish)	Johnson/ Kajaria
30	Glazed Vitrified Tiles Rectified (Satin Finish)	Johnson / Kajaria
31	Glass	Saint Gobain / Modi Guard
32	Wall Putty	Birla / JK White

It is certified that I have gone through the above list of preferred make of materials and the rates has been quoted accordingly.

(Signature of Contractor)

PARTICULAR SPECIFICATIONS OF WORK

1.0 R.C.C. WORK:-

1.1 Design Mix Concrete

1.1.1 The Contractor shall design mixes for each class of concrete indicating that the concrete ingredients and proportions will result in concrete mix meeting the requirements specified at his own cost. Nothing shall be paid on this account to the contractor .

- a) The contractor has to submit design mix without use of admixtures.
- b) Admixture may be added (by maintaining the minimum cement content as given under para- 2.1.3) in case of specific technical requirement so as to meet the workability / slump requirement or for any other reason but nothing extra is to be paid to contractor on account of adding admixtures.

1.1.2 The sources of coarse aggregate, fine aggregate, water, admixture, fly ash & cement to be used in concrete work shall be identified by the contractor & he will satisfy himself regarding their conforming to the relevant specifications & their availability before getting the same approved from the Engineer-In-Charge.

- a) **Coarse Aggregate:-**As per Indian Standard Specification of CPWD and PWD Jharkhand Specifications
- b) **Fine Aggregate:-**As per Indian Standard Specification of CPWD and PWD Jharkhand Specifications
- c) **Water:-**It shall conform to requirements laid down in IS:456-2000 / Para 5.4 or JSOR Specifications
- d) **Cement:-**As per Indian Standard Specification of CPWD and PWD Jharkhand Specifications.
- e) **Admixture / Plasticizer** – As per Indian Standard Specification of CPWD and PWD Jharkhand Specifications. The admixture shall conform to IS: 9103. Whenever required, the admixture of approved quality & approved make only shall be used to attain the required workability. Nothing extra on account of use of Admixture / Plasticizer shall be payable.

1.1.3 The Contractor shall engage, at his own cost, one of the following approved laboratories / test house for designing the concrete mix in accordance with relevant IS Code and to conduct laboratory tests to ensure the target strength & workability criteria for a given grade of concrete:-

Tests shall be carried out from one of the following laboratories/test houses as shall be decided by the Engineer in- charge.

- (i) National Test House, Kolkata
- (ii) Shri Ram Institute for Industrial Research, New Delhi
- (iii) NABL accredited labs.
- (iv) Any Government Technical Institute / Lab.

2.0 **BATCHING & MIXING:-**

- (a) All design mix concrete shall be done using fully automatic / semi automatic batching plant conforming to IS: 4925 of minimum 6 cum per hour capacity. The automatic / semi automatic batching plant shall be charged by devices when actuated by a single starter switch, will automatically start the weighing operation of each material (i.e. stone aggregate, sand, cement, water, admixture etc.) and stop automatically when designated weight of each material has been reached and also it should have rated capacity (in terms of concrete in a single batch). It shall have control panel for operation of the batching plant complete with printing facility.
- (b) In the event of mal functioning of batching plant or for any other reason for non production of batched concrete at site the contractor shall be free to use Ready Mix Concrete (RMC) at his cost. The contractor shall ensure that transit mixtures shall transport the concrete to site. All the precautions shall be taken during the transportation and handling of concrete to achieve the desired strength, durability, etc. as envisaged in the Mix Design. Contractor has to get the approval from Engineer-In-Charge regarding source of RMC by giving the details of such plants indicating name of owner / company, its location, technical establishment, past experience and text of Memorandum of Understanding (proposed to be entered between purchaser and supplier). The Engineer-in-Charge, after satisfying himself about quality / capability of the company shall give approval in writing (subject to drawing of MOU). The MOU shall be drawn with RMC plant owner / company and submitted to Engineer-in-Charge within a week of such approval. The contractor will not be allowed to purchase RMC without completion of above formalities for use in the project. Notwithstanding the approval granted by Engineer-in-Charge in aforesaid manner, the contractor shall be fully responsible for quality of concrete including input control, production, transportation and placement etc. The Engineer-in-Charge will reserve the right to deploy his supervisor at plant site to inspect at any such stage and reject the material / concrete etc if he is not satisfied about quality of material / product.
- (c) All measuring equipment shall be maintained in a clean and serviceable condition and their accuracy shall be checked at least once a month.
- (d) Only single sized good quality stone aggregate shall be brought to site of work from the approved source. The grading of the stone aggregate shall be controlled by blending the aggregate of different sizes in the required proportions at site of work. The aggregate of different sizes shall be stock-piled separately, preferably a day before use.

The grading of coarse and fine aggregates shall be checked as frequently as possible and as directed by the Engineer-In-Charge to ensure that the specified grading and quality of aggregate is maintained.

- (e) It is important to maintain the Water Cement Ratio constant at its specified or approved value by making adjustment for the moisture contents of both fine and coarse aggregates. The moisture contents in the aggregate shall be determined as frequently as possible in keeping with the weather conditions and as per the provisions of IS: 2386 (Part-III).
- (f) If the quantity of cement in approved design mix is less than the minimum quantity of cement specified in the item, the same shall be recovered from the contractor. However, If the quantity of cement in approved design mix is more than the minimum quantity of cement specified in the item, nothing extra shall be paid.

5.0 Pumping and placing in position:

- 5.1 The concrete shall be laid in position with the stationary pump or truck mounted pump connected with pipe lines. It may also be placed in position with the help of tower crane etc.
- 5.2. Placing :
 - 5.2.1. Concreting shall be commenced only after Engineer-in-charge has inspected and approved the centering, shuttering and reinforcement arrangements. Shuttering shall be clean and free from all shavings, saw dust, pieces of wood, or other foreign materials. Concrete shall not be deposited under water.
 - 5.2.2 In case of concreting of slabs and beams, wooden plank or cat walks of chequered MS plates or bamboo chalties or any other suitable material supported directly on the centering by means of wooden blocks or lugs shall be provided to convey the concrete to the place of deposition without disturbing the reinforcement in any way. Labour shall not be allowed to walk over the reinforcement.
 - 5.2.3 In case of columns and walls, it is desirable to place concrete without construction joints. The progress of concreting in the vertical direction, shall be restricted to one metre per hour.
 - 5.2.4 The concrete shall be deposited in its final position in a manner to preclude segregation of ingredients. In deep trenches and footings concrete shall be placed through flexible pipe / chutes or as directed by the Engineer-in-Charge. In case of columns and walls, the shuttering shall be so adjusted that the vertical drop of concrete is not more than 1.5 metres at a time.
 - 5.2.5. The Concrete shall be deposited by pumps / tower crane as nearly as practicable in its final position to avoid re-handling. It shall be laid gently (not thrown) and shall be thoroughly vibrated and compacted before setting commences and should not be subsequently disturbed. Method of placing shall be such as to preclude segregation. Care shall be taken to avoid displacement of reinforcement or movement of form work and damage due to rains.

5.2.6 Construction Joint

5.2.6.1 Concreting shall be carried out continuously upto the construction joints, the position and details of which shall be as shown in structural drawing or as indicated in JSOR Specification or as directed by Engineer-in-charge. Number of such joints shall be kept to minimum. These shall be straight and shall be at right angles to the direction of main reinforcement.

Construction joints should comply with IS : 11817.

5.2.6.2 In case of columns the joints shall be horizontal and 10 to 15 cm below the bottom of the beam running into the column head. The portion of the column between the stepping off level and the top of the slab shall be concreted with the beam.

5.2.6.3 When stopping the concrete on a vertical plane in slabs and beams, an approved stop-board in JSOR Specification) shall be placed with necessary slots for reinforcement bars or any other obstruction to pass the bars freely without bending. The construction joints shall be keyed by providing a triangular or trapezoidal fillet nailed on the stop-board. Inclined or feather joints shall not be permitted. Any concrete flowing through the joints of stop-board shall be removed soon after the initial set. When concrete is stopped on a horizontal plane, the surface shall be roughened and cleaned after the initial set.

5.2.6.4 When the concrete is to be resumed, the joint shall be thoroughly cleaned with wire brush and loose particles removed. A coat of neat cement slurry at the rate of 2.75 kg of cement per square meter shall then be applied on the roughened surface before fresh concrete is laid.

6. **Compaction:**

6.1 Concrete shall be thoroughly compacted and fully worked around embedded fixtures and into corners of the form work. Compaction shall be done by mechanical vibrator of appropriate type till a dense concrete is obtained. The Mechanical vibrators shall conform to IS 2505, IS:2506, IS:2514, and IS:4656. To prevent segregation, over vibration shall be avoided.

6.2 Compaction shall be completed before the initial setting starts. For the items where mechanical vibrators are not possible to be used, the contractor shall take permission of the Engineer-in-charge in writing before the start of the work. After compaction, the top surface shall be finished even and smooth with wooden trowel before the concrete begins to set.

6.3 Concrete shall be compacted into dense mass immediately after placing by means of mechanical vibrators designed for continuous operations. The Engineer-in-Charge may however relax this conditions at his discretion for certain items, depending on the thickness of the members and feasibility of vibrating the same and permit hand compaction instead. Hand compaction

shall be done with the help of tamping rods so that concrete is thoroughly compacted and completely worked around the reinforcement, embedded fixtures, and into corners of the form. The layers of concrete shall be so placed that the bottom layer does not finally set before the top layer is placed. The vibrators shall maintain the whole of concrete under treatment in an adequate state of agitation, such that de-aeration and effective compaction is attained at a rate commensurate with the supply of concrete. The vibration shall continue during the whole period occupied by placing of concrete, the vibrators being adjusted so that the centre of vibrations approximates to the centre of the mass being compacted at the time of placing.

- 6.4 Concrete shall be judged to be properly compacted, when the mortar fills the spaces between the coarse aggregate and begins to cream up to form an even surface. When this condition has been attained, the vibrator shall be stopped in case of vibrating tables and external vibrators. Needle vibrators / internal vibrators shall be withdrawn slowly so as to prevent formation of loose pockets. In case both internal and external vibrators are being used, the internal vibrator shall be first withdrawn slowly after which the external vibrators shall be stopped so that no loose pocket is left in the body of the concrete. The specific Contractor instructions of the makers of the particular type of vibrator used shall be strictly complied with. Shaking of reinforcement for the purpose of compaction should be avoided. Compaction shall be completed before the initial setting starts or extended initial setting time in case where retarder is used.

7. Curing:

- 7.1. As soon as concrete is compacted and levelled, the exposed surface shall be covered with polythene sheet for initial two to three hours after laying of the concrete so that moisture loss from the concrete can be prevented.
- 7.2. When the concrete begins to harden i.e. two to three hours after compaction, the exposed surfaces shall be kept damp with moist gunny bags, sand or any other material approved by the Engineer – in - charge. 24 hours after compaction, the exposed surface shall be kept continuously in damp or wet conditions by ponding or by covering with a layer of sacking , canvass, Hessian or similar absorbent materials and kept constantly wet for at least 10 days from the date of placing of concrete.
- 7.3 Approved curing compounds may be used in lieu of moist curing with the written permission of the Engineer-in-Charge. Such compounds shall be applied to all exposed surfaces of the concrete as soon as possible after the concrete has set.

- 7.4 Freshly laid concrete shall be protected from rain by suitable covering.
- 7.5 Over the foundation concrete, the masonry work may be started after 48 hours of its compaction but the curing of exposed surfaces of cement concrete shall be continued along with the masonry work for at least 10 days. And where cement concrete is used as base concrete for flooring, the flooring may be commenced before the curing period of base concrete is over but the curing of base concrete shall be continued along with top layer of flooring for a minimum, period of 10 days.

9. Finishing :

- 8.1. In case of roof slabs the top surface shall be finished even and smooth with wooden trowel, before the concrete begins to set.
- 8.2. Immediately on removal of forms, the RCC work shall be examined by the Engineer-in-Charge, before any honey combs / defects are made good.
- 8.3 Surface defects of a minor nature may be accepted. On acceptance of such a work by the Engineer - in - Charge, the same shall be rectified as follows:
- a)** Surface defects which require repair when forms are removed, usually consist of bulges due to movement of forms, ridges at form joints, honey combed areas, damage resulting from the stripping of forms and bolt holes, bulges and ridges are removed by careful chipping or tooling and the surface is then rubbed with a grinding stone. Honey-combed and other defective areas shall be chipped out, the edges being cut as straight as possible and perpendicular to the surface, or preferably slightly undercut to provide a key at the edge of the patch.
 - b)** Shallow patches shall first treated with a coat of thin grout composed of one part of cement and one part of fine sand and then filled with mortar similar to that used in the concrete. The mortar is placed in layers not more than 10 mm thick and each layer is given a scratch finish to secure bond with the succeeding layer. The last layer is finished to match the surrounding concrete by floating, rubbing or tooling on formed surfaces by pressing the form material against the patch while the mortar is still plastic.
 - c)** Large and deep patches require filling up with concrete held in place by forms. Such patches are reinforced and carefully dowelled to the hardened concrete.
 - d)** Holes left by bolts are filled with mortar carefully packed into places in small amounts. The mortar is mixed as dry as possible, with just enough water so that it will be tightly compacted when forced into place.
 - e)** Tiered holes extending right through the concrete may be filled with mortar with a pressure gun similar to the gun used for greasing motor cars

- f) Normally, patches appear darker than the surrounding concrete, possibly owing to the presence on their surface of less cement laitance. Where uniform surface colour is important, this defect shall be remedied by adding 10 to 20 percent of white Portland cement to the patching mortar. The exact quantity being determined by trial.
 - g) The same amount of care to cure the material in the patches should be taken as with the whole structure, Curing must be started as soon as possible, after the patch is finished to prevent early drying. Damp Hessian may be used but in some locations it may be difficult to hold it in place. A membrane curing compound in these cases will be most convenient.
- 8.4 The surface which is to receive plaster or where it is to be joined with brick masonry wall, shall be properly roughened immediately after the shuttering is removed, taking care to remove the laitance completely without disturbing the concrete. The roughening shall be done by hacking. Before the surface is plastered, it shall be cleaned and wetted so as to give bond between concrete and plaster. RCC work shall be done carefully so that the thickness of plaster required for finishing the surface is not more than 6 mm.
- 8.5 The surface of RCC slab on which the flooring with cement base is to be laid shall be roughened with brushes while the concrete is green. This shall be done without disturbing the concrete.

9.0 FORM WORK

- 9.1 The work shall be done in general as per Indian Standard Specification of CPWD and PWD Jharkhand Specifications
- 9.2 Only M.S. centring / shuttering and scaffolding material unless & otherwise specified shall be used for all R.C.C. work to give an even finish of concrete surface.
- 9.3 In order to keep the floor finish as per architectural drawings and to provide required thickness of the flooring as per specifications, the level of top surface of R.C.C. shall be accordingly adjusted at the time of its centring, shuttering and casting for which nothing extra shall be paid to the Contractor.
- As per general engineering practice, level of floors in toilet / bath, balconies, shall be kept 12 to 20mm or as required, lower than general floors shuttering should be adjusted accordingly. Nothing extra is payable on this account.
- 9.4 Steel shuttering as approved by the Engineer-in-Charge shall be used by the contractor. Minimum size of shuttering plates shall be 600mm x 900mm except for the case when closing pieces are required to complete the shuttering panels. Dented, broken, cracked, twisted or rusted shuttering

plates shall not be allowed to be used on the work. The shuttering plates shall be cleaned properly with electrically driven sanders to remove any cement slurry or cement mortar or rust. Proper shuttering oil or de-bonding compound shall be applied on the surface of the shuttering plates in the requisite quantity before assembly of steel reinforcement.

10.0 **REINFORCEMENT:-**

The reinforcement shall be done as per JSOR Specifications.

10.1 The rate of item of reinforcement of RCC work includes all operations including straightening, cutting, bending, welding, binding with annealed steel or welding and placing in position at all the floors with all leads and lift complete as per Indian Standard Specification of CPWD and PWD Jharkhand Specifications.

10.2 The contractor shall provide approved type of support for maintaining the bars in position and ensuring required spacing and correct cover of concrete to reinforcement as called for in the drawings, spacer blocks of required shape and size. Chairs and spacer bars shall be used in order to ensure accurate positioning of reinforcement. **Spacer blocks shall be cast well in advance with approved proprietary pre-packed free flowing mortars (Conbextra as manufactured by M/S Fosroc Chemicals India Ltd. or approved equivalent)** of high early strength and same colour as surrounding concrete, Pre-cast cement mortar/concrete blocks/blocks of polymer shall not be used as spacer blocks unless specially approved by the Engineer-in-charge, rate of RCC items is inclusive of cost of such cover blocks.

11.0 **PRE-CAST RCC WORK:-**

11.1 The work shall be done in accordance with Indian Standard Specification of CPWD and PWD Jharkhand Specifications.

11.2 Pre-cast reinforced concrete units shall be of grade or mix as specified. Provision shall be made in the mould to accommodate fixing devices such as hooks etc. and forming of notches and holes. Each unit shall be cast in one operation. A sample of the unit shall be got approved from Engineer-in-charge before taking up the work.

11.3 Pre-cast units shall be clearly marked to indicate the top of member and its location.

11.4 Pre-cast units shall be stored, transported and placed in position in such a manner that these are not damaged.

- 11.5 The compaction of the concrete shall be done by vibrating, table or external vibrator, as approved by Engineer-in-charge. The rate quoted for the item shall include the element for framework and mechanical vibration.
- 11.6 Rate for item includes cost of all materials, labour, and all operations involved. Cost of M.S. frames, lugs including their welding, lifting hooks is also included.

12.0 BRICK WORK:-

- 12.1 The brickwork shall be carried out with good quality well burnt FPS bricks/ clay fly ash bricks of class designation 50 as per CPWD and PWD, Jharkhand Specification, as specified in the item.
- 12.2 The rate shall also include for leaving chases / notches for dowels / cramps for all kinds of cladding to come over brick work.
- 12.3 Brick work provided around shaft or lift walls or around slab cutouts shall be measured in the brick for corresponding floor level. Nothing extra shall be paid on this account.

13.0 FINISHING:-

- 13.1 The work shall be done in accordance with Indian Standard Specification of CPWD and PWD Jharkhand Specifications.
- 13.2 All painting material of approved brand and manufacturer shall be brought to the site of work in the original sealed containers. The material brought to the site of work shall be sufficient for at least 30 days of work. The material shall be kept under the joint custody of contractor and representative of the Engineer-in-charge. The empty containers shall not be removed from the site till the completion of the work without permission of the Engineer-in-charge.

TECHNICAL SPECIFICATION FOR SITC OF ELECTRICAL INSTALLATIONS & FANS, COMPOUND LIGHTING, PUMP SETS AND CONNECTED WORKS.

I) TECHNICAL SPECIFICATION FOR LT/ MV SWITCH BOARDS

1.1.0 SCOPE

This specification covers the technical requirements of manufacture, supply, installing, testing & commissioning L.T/MV Switch Boards complete with all accessories for efficient and trouble free operation at site.

1.2.0 STANDARDS

The equipment covered by this specification shall, unless otherwise stated, shall be designed, constructed and tested in accordance with the latest revisions of relevant Indian Standards/ Indian Standard Specification of CPWD and PWD Jharkhand Specifications (Internal) and shall conform to the regulations of local statutory Authorities.

1.3.0 CONSTRUCTION

- 1.3.1 The panel shall be metal-enclosed, freestanding compartmentalized type suitable for indoor installation. The panel shall be dust and vermin proof. The panel shall be of uniform overall height not exceeding 2300 mm.
- 1.3.2 The panel shall be fabricated out of 2mm thick CRCA mild steel structural sections. All the doors and covers shall be fabricated out of 1.60mm thickness CRCA mild steel sheet.
- 1.3.3 Each of the outgoing feeder terminals in the switch board, terminal are brought out to the cable chamber to form convenient connection of the outgoing cables.
- 1.3.4 (a) Incomers and outgoing feeders shall be provided with their own separate modules having separate doors, isolating switch of each units shall be mechanically interlocked with its respective doors.
(B) However a provision shall be made to defeat this interlock for testing the switch in its closed position.
- 1.3.5 (a) Each cable chamber shall have cable entry from bottom / Top and suitable removable gland plates shall be provided for this purpose.
(b) The cable chamber shall be provided with suitable supporting arrangement between the gland plate and terminals, in the middle.
(c) The cable chamber shall have a minimum width of 300 mm depending upon the outgoing cables.
- 1.3.6 Out going links from feeder shall be rigidly supported and suitably extended in cable chamber for easy cable connection.
- 1.3.7 (a) All retaining catches, screws and bolts for doors and covers shall be cadmium plated.
(b) Screws and bolts shall be captive.
(c) All covers, doors and joints shall be gasketed.
- 1.3.8 (a) Equipment to be mounted outside cubicles shall be flush mounted on cubicle door.

- (b) No externally mounted equipment shall be mounted above 1.8m or below 0.3m above floor level.
- 1.3.9 (a) All panels and covers shall be properly fitted and square with the frames and holes in the panel correctly positioned.
- (b) The board shall be of totally enclosed design, completely dust proof and vermin proof.
- (c) Gaskets between all adjacent and beneath all covers shall be used to render the joint effectively dust proof.
- (d) Soft compressible gasket shall be used between all metal joints, doors and covers to prevent ingress of dust.
- 1.3.10 (a) All similar materials and removable parts of the switchboard shall be interchangeable.
- (b) The switchboards shall be fitted with the same family of switches of various ratings with a view to ensure uniformity of design, maintenance and replacements.
- (c) Separate and adequate compartments shall be provided for accommodating instruments, indicating lamps, control contractors and control fuses etc. These shall be accessible for testing and maintenance without any danger of accidental contact with live parts of the circuit breaker bus bar connections.
- 1.3.11 (a) A base channel of 75 mm x 40 mmx3mm thick hot rolled sheet steel channel section, painted black shall be provided to prevent corrosion of the sheet steel cubicles and facilitate cleaning of floors. For convenience of operation and cable termination, there shall be a gap of at least 150 mm between the floor level and bottom most unit.

2.4.0 BUSBARS

- 2.4.1 (a) The busbars shall be air insulated and made up of high conductivity, Aluminium.
- (b) All busbars shall be fully screened by means of PVC sleeves in their own compartment running throughout the length of the panel and also suitable allowance shall be made for bus expansion.
- (a) Suitable segregation shall be provided in between busbar chamber and adjoining compartments.
- (d) The busbar shall be PVC sleeved with colour strips of red, yellow, blue and black.
- (e) The busbars shall be TP and N, the section of the neutral bus being same size of the phase busbar.
- (f) The busbar shall be properly segregated, suitably braced with insulated supports (DMC/FRP/SMC) placed at appropriate (450mm) intervals to withstand the electromagnetic stresses during short circuit.
- (g) Minimum electrical clearances shall be maintained between phase,

neutral and body as per standards.

2.5.0 INTERCONNECTION

- 2.5.1 (a) Switchboard shall be completely factory wired ready for connecting to equipment.
- (b) Power connection of the circuit shall be done by Aluminum flats or by adequate size of PVC insulated stranded copper wires.
- 2.5.2 (c) Control wiring shall be done by PVC insulated wires of minimum size 1.5 sq.mm copper.
- (d) All control wiring shall be fitted with identical identification ferrules at each end.
- (e) Not more than two connections shall be made at any one terminal. The wires shall be arranged and supported in such a manner that there shall be no strain on terminations.
- 2.5.3 (a) Suitable size and capacity of aluminium/ copper busbars shall be provided for interconnections between switches and main busbars for switches above 63Amps.
- (b) The interconnections of all the phases between the busbars and the incoming side of the switch cubicle shall be inaccessible when the doors of the controls are opened for removal of fuses etc.
- 2.5.4 For each and every tapplings from the busbars, separate connections shall be made. No direct tapplings from the busbar shall be made for any feeder without control and protection.
- 2.5.5 (a) The incoming and outgoing cable shall be properly identified and also the circuit to which it is connected on each outlet.
- (b) The size and number of runs of cables and load which it feeds shall be clearly written on the cable near the termination.

2.6.0 AIR CIRCUIT BREAKERS

2.6.1 General

- a. Air circuit breakers shall be of 3 poles / 4 poles and shall have over load, short Circuit and Earth Fault protections as specified in the schedule of work.
- b. Should be suitable for Isolation as per standard and shall have the Isolation between power circuit and Control circuit.
- c. Shall have Micro Processor trip-release.
- d. Should have facility of local fault identification (O/C, SC, E/F).

2.6.2 Construction

(a) General: It shall have / be

- i) Motor wound spring closing mechanism wherever specified.

- ii) Full draw-out type with indication for service, test and isolated positions.
- iii) Trip free mechanism.
- iv) Mechanical open, closed and spring charges indicator.
- v) Main contacts made up of copper.
- vi) Magnetic blow out arc control device.
- vii) Facilities for pad locking.
- viii) ACB shall have Line and Load Reversibility.
- (b) The circuit breaker shall be fully draw out type. Suitable guides shall be provided to facilitate easy withdrawal of the trolley. All identical feeder compartments shall be inter-changeable.
- (c) All current carrying contacts of the breaker shall be silver plated. Contacts subjected to arcing shall be tipped with suitable arc resisting material.
- (d) Shall have facility of O/C Pre-Trip alarm at set current.
- (e) The contacts shall be self-aligning, plug-in type, designed to ensure adequate contact pressure on the main busbars requiring minimum maintenance.

2.6.3 Operating Mechanism

- (a) The operating mechanism shall be trip-free.
- (b) Failure of spring, vibrations or shocks shall not cause unintended operation of breaker or prevent intended tripping operation.
- (c) Closing of breakers shall be prevented unless the spring is fully charged.

2.6.4 Interlocks

- (a) The breaker shall be provided with all necessary interlocks to prevent inadvertent operations and to ensure safety of operating personnel and also the equipment.
- (b) It shall not be possible to push in a drawn out breaker in closed condition or withdraw a breaker in closed condition.
- (c) Compartment doors shall be interlocked against opening when breaker is in 'Closed' condition.
- (d) It shall not be possible to operate the breaker in intermediate position while inserting or withdrawing a circuit breaker.

- 2.6.5 The frame of the circuit breaker should be positively earthed, when the breaker is racked in back to the cubicle.

2.7.0 MOULDED CASE CIRCUIT BREAKERS

2.7.1 General:

- i. MCCB shall have Thermal Magnetic release up to 250A & shall have Micro – Processor releases of above 250A.

- ii. Micro processor releases should be EMC (electronic module control) compatibility.
 - iii. Should have the facility to change the setting in on condition.
 - iv. Shall have the Isolation between power circuit and Control circuit.
 - v. Shall have front door handles.
- 2.7.2. (a) The MCCB shall comprise of switching mechanism, contact system, arc extinguishing device and the tripping unit all mounted inside a molded case.
- (b) The MCCB shall be provided with field settable over load protection and S/C protection.
- 2.7.3 (a) MCCB shall employ quick make and quick break switching mechanism independent of the speed of operation of the operating handle.
- (b) The operating mechanism also be trip free. The operating handle shall indicate the position of the MCCB in ON / OFF / TRIPPED. The operating handle shall have provision for padlocking.
- (c) Door interlocking shall be provided.

2.7.4 CHANGEOVER SYSTEM :

- i. MCCBS should be electrically and mechanically interlocked as per the drawings and schedule of work.
- ii. Mechanical interlock should be done with MCCB fitted in the mechanical frame with interlock lever. Frame should be fitted in either direction (vertical or horizontal)

2.8.0 CABLE COMPARTMENT

- i. A full height compartment shall be provided for easy terminations of all incoming and outgoing cables entering either from top or from bottom. Adequate supports shall be provided for the cable wherever necessary.**
- ii. The cable compartment shall have its own-hinged cover that can be removed for easy access during cabling.

2.9.0 CONTACTORS

- i. Contactor shall be of electromagnetic type rated for uninterrupted duty unless otherwise specified and also suitable for capacitor duty.
- ii. The main contacts shall be of silver or silver alloy.
- iii. Each contactor shall be provided with 2 N/O and N/C aux. contacts.
- iv. Contactor coil rating shall be minimum pick up of 85% of rated voltage and minimum drop out of 75% rated voltage.

2.10.0 PUSH BUTTONS

- (a) Push buttons shall be generally shrouded.
- (b) Each push button shall be provided with 1 N/O and 1 N/C aux. contacts. "Stop" push button shall have, 'stay-put' feature.

2.11.0 INDICATION

2.11.1 Indication lamps shall be provided in each feeder with indication 'ON' or 'OFF' under trip.

2.11.2 Potential free contact shall be provided for monitoring ON / OFF / Trip status from remote.

2.12.0 SPACE HEATERS

Anti condensation space heaters, with thermostat suitable for 230 V, 1 Ph supply along with a switch / fuse/indication lamps shall be provided in each panel.

2.13.0 CONTROL SWITCHES

- (a) A general purpose control switch shall be provided for selection of "Auto" & "Manual".
- (b) The switch shall be provided with engraving plate in the front with "Auto", "Manual" & "Off" inscription.
- (c) This switch shall be normally of the fixed-control bar type heavy duty unit.

2.14.0 MEASURING INSTRUMENTS

- (a) Ammeters and Voltmeters shall be of digital type. They shall be industrial grade and shall have means of zero adjustment from the front without dismantling them.
- (b) They shall be capable of carrying the normal full load current (via CTS) and shall not be damaged by effects of rated fault current.
- (c) The instruments shall have an accuracy class of 1.0.

2.15.0 CONTROL WIRING

2.15.1 Panel shall be supplied with all internal wiring comprising of PVC insulated 1.1 KV grade, multi stranded flexible copper conductor of 1.5 Sq.mm cross section.

2.15.2 Wiring associated with a particular phase shall be the colour of that phase viz. Red / Yellow, or Blue, wiring associated with earthing shall be with green colour insulation and for neutral it shall be with black colour insulation.

2.15.3 Wiring shall be neatly laid and run on insulated cleats of limited compression type insulated straps.

2.15.4 All cables shall have crimped terminations and shall be identified by means of glossy plastic ferrules at both ends, showing the wire number as indicated in the schematic diagrams. The ferrules shall be indelibly marked.

2.15.5 Wiring to items mounted on hinged doors or wiring that is subject to movement, shall run in helical binding. The binding shall be securely anchored at both ends and sufficient slack provided to prevent any strain being imposed on wiring.

2.16.0 EARTHING

- 2.16.1 All the metal parts of all equipment supplied within the panel (including doors and gland plates) other than those forming part of all electric circuit, shall be connected by means of two independent earth conductors to continuous copper earth bar of size 25 x 5 mm running along the full length of the panel.
- 2.16.2 The panel shall be provided with two brass earthing stud terminals, with suitable nuts, washers etc. for connection to ground bus.

2.17.0 TERMINAL BLOCK

- 2.17.1 Terminal blocks shall preferably be grouped according to circuit functions and each terminal block group shall have atleast 10% spare terminals. Terminal blocks for control circuit shall be of 650V grade with contact ratings not less than 10A and stud/clamp type.
- 2.17.2 Not more than two wires shall be connected to any terminal block.

2.18.0 LABELS

- 2.18.1 Labels shall be provided to describe the duty of or otherwise identify every Instrument, or other item of equipment mounted internally and externally. Switch positions shall be fully identified. Wording shall be clear, concise and unambiguous.
- 2.18.2 Each label shall be permanently secured to the panel surface below the item to which it refers.
- 2.18.3 The labels shall be engraved plastic with white letters in black background.
- 2.18.4 In addition to component labels, each cubicle door shall bear a large identification labels and the panel shall include large, prominent overall identification label.

2.19.0 PAINTING

- 2.19.1 Care shall be taken in workmanship and selection of materials to prevent the occurrence of any form of damage or corrosion due to damp or highly humid conditions.
- 2.19.2 The panel shall be prepared, primed, filled and painted to the highest standards. All items shall be cleaned and deburred after fabrication and welding is complete. External surfaces shall be filled and rubbed down as necessary to obtain a perfectly flat smooth surface free from blemishes and imperfections and the whole shall be Powder Coated with Epoxy paint and the shade shall be as per approved Engineer-in-charge .
- 2.19.3 The panels shall be fabricated at such work shops where the following facilities are available and the panels are subject to the following processes. Necessary certificate to this effect shall be submitted.
- Sand blasting
Pretreatment (Seven tank process)

Spray booth
 Heating in the oven for all sizes of panels.
 Heat shrinking of PVC sleeves.

II) SPECIFICATION FOR CABLE LAYING

- 3.1.1 The work shall be carried out strictly in accordance with general Indian Standard Specification of CPWD and PWD Jharkhand Specifications for electrical works {Part 2 External} 1994 amended upto date.
- 3.1.2 All cables shall be laid in ground, trenches & or on walls, trays as may be specified and as per schematic diagram.
- 3.1.3 Cables shall be laid in the routes marked in the drawings. Where the route is not marked, the contractor shall mark it out on the drawings and also on the site and obtain the approval of the Engineer-in-charge before laying the cable.
- 3.1.4. All cables shall be clamped properly when laid along the wall /ceiling /cable tray. Cables laid in built-up trenches shall be on steel supports. Aluminium identification tags shall be provided at every 20 m.
- 3.1.5. Cables shall be bent to a radius not less than 12 times the overall diameter of the cable, or in accordance with the manufacturer's recommendations whichever is higher.
- 3.1.6. Cables shall be identified at end terminations indicating the feeder number and size and no. of runs and the Panel / Distribution Board from where it is being laid.
- 3.1.7 (a) For Cables laid in soil, the cable route shall be parallel or perpendicular to roadways, walls, etc.,
 (b) Cables shall be laid in an excavated, graded trench, over sand cushion to provide protection against abrasion.
 (c) Width of excavated trenches shall be as per drawings/ department specifications.

	<u>Width of trench</u>	<u>Height of trench</u>	<u>Sand cushioning</u>	
i. For MV cable	350mm	750mm	750mm	250mm
ii. For HT cable	350mm	1200mm	1200mm	250mm

- 3.1.8 The cables laid in the excavated trenches shall be protected with bricks over the cable. The bricks should be laid laterally to the trench.
- 3.1.9 The cables laid in buried underground trench shall be provided with cable markers at every 10 metres.
- 3.1.10 (a) All cable terminations for conductors' upto 4 sq.mm may be insertion type and all higher sizes shall have compression lugs.
 (b) Cable terminations shall have necessary brass glands.
- 3.1.11. Wherever cables pass through floor or through wall openings, it shall be taken through HDPE PVC/GI sleeves. The open ends of the sleeves shall be

sealed by cold setting compound after cables are pulled through them to prevent entry of vermin and ingress of water.

- 3.1.12. In making connection on switches and other terminals no strand of conductor shall be cut to facilitate termination.
- 3.1.13. Cable armouring shall be earthed at both ends.
- 3.1.13. The cable shall be as per the relevant IS amended from time to time, Test certificate should be submitted by the contractor for the cables supplied by him.
- 3.1.14. The contractor at his own cost and risk shall arrange all necessary tools & plants. The contractor will be held responsible for any damage to the building or equipment at the time execution of work.

TESTING:

- 3.1.14. Testing of complete cable installation shall be done as provided in general Specification for electrical works (Part 2 External) 1994/1995 amended up to date.
- 3.1.15. MV cables shall be tested after installation with a 500 V Muggger and the following readings established.
 - 1) Continuity on all phases
 - 2) Insulation Resistance (a) between conductors
(b) All conductors and ground

All test readings shall be recorded in the separate book and the same to be handed over to the Engineer-in-charge.

III) SPECIFICATION FOR THE WORK OF PROVIDING EI&FANS

- 4.1 The works shall be done as per current JSOR Specifications for electrical works (Internal, External) as amended from time to time and Indian Electricity rules as amended up to date.

- 4.2. The work shall be supervised by qualified Electrical staff.
- 4.3. The layout of the work will be given by Engineer-in-charge or his duly authorized representative at site of work.
- 4.4. The following wiring shall be done on separate conduits.
 - a. Power plug wiring
 - b. Light and fan wiring.
 - c. Emergency Light wiring(DC/AC supply)
 - d. Telephone/LAN Wiring
 - e. AC units wiring
- 4.5. The earthing has to be done in the presence of Engineer-in-charge or his authorized representative.
- 4.6.
 - a. The MS conduit shall be of IS marked, stove enameled.
 - b. The conduits shall be delivered to site in original bundles and each length shall bear the label of the manufacturer.
 - c. The materials brought at site shall be with proper challan with quantity mentioned on it.
- 4.7.
 - a. The makes of material have been indicated in the list of approved makes. No other make will be acceptable.
 - b. The material to be used in the work shall be got approved from the Engineer-in-charge before its use at site. The Engineer-in-charge shall reserve the right to instruct the contractor to remove the material which, in his opinion, is not as per specifications.
- 4.8. The no. of light points fed from the AC / DC supply shall not exceed 10 points or 800 watts per Circuits, whichever is less.
- 4.9. All the Copper wires shall be multi-stranded conductor. Termination of multi-stranded conductors shall be done using crimping type thimbles at both the ends. Nothing extra shall be paid for the same
- 4.10. All hardware material such as nuts/bolts /screws/washers etc. to be used in the work shall be zinc/cadmium galvanized iron.
- 4.11.
 - a. Extra module 1No. for switch boxes where 4Nos. and above 4Nos. of switches shall be provided in the modular switch box for future use without any extra cost.
 - b. The extra modules shall be provided with blanking plates without any extra cost.
- 4.12. Modular type switches/sockets/telephone outlets to be provided shall be as per approved makes.
- 4.13. Different categories of conduit/ runs/ face plates catering for different types of electrical wiring as mentioned in clause (4.4) above shall be painted with different colour each signifying a particular category mentioned, so as to avoid mixing of various circuits and their wiring and nothing extra will be paid for this.

- 4.14 a. The outer surface of conduits including all bends, unions, tees, junction boxes etc. forming part of the conduit system, shall be adequately protected against rust.
- b. The conduits are to be painted with 2 coats of red oxide paint before they are fixed.
- c. All bare threaded portions shall be treated with anticorrosive preservative (or) approved plastic compound.
- 4.15 (a) At the time of laying conduit pipe in the slab in recess, the contractor will keep fish wires of 16 SWG GI wire throughout conduit pipe and will have to take special care so that the conduits do not pass through air-conditioning ducts, grills, beams etc.
- (b) If any, such necessity is foreseen special written permission of the Engineer-in-charge will be obtained before such work is carried out.
- (c) In case of failure, to do as above, the contractor will not be paid on this account and the work has to be redone by the contractor as per direction of Engineer-in-charge.
- 4.16 (a) The conduits are to be concealed in the walls before the walls are plastered and work is to be done in coordination with building work. Any damage thus done will have to be made good by the contractor at his own risk and cost.
- (b) The conduit pipe should mechanically and electrically be continuous.
- 4.17 The circuit wiring is to be meticulously planned and carried out in the most economical manner avoiding columns crossing etc.
- 4.18 a. The point wiring will be extended up to the fitting/ceiling rose etc. directly without provision of any termination arrangement in between.
- b. The wiring from the end point up to the fixture shall be considered to be included in the respective item of installation of that fixture. Nothing extra shall be paid for the same.
- 4.19. Wherever it is not possible to provide rigid conduits, flexible metallic pipe shall be provided for running the wires. However, such arrangement has to be kept to the barest minimum and to be done only with the prior approval of Engineer-in-charge.
- 4.20. All fittings/fans will be earthed with 1.5 Sq.mm PVC insulated multi strand copper conductor.
- 4.21. (a) All the distribution board, sub-main board and their complete fitting shall be signwritten clearly indicating the number of distribution board, the type of load it is serving and the number of circuit contained in the distribution box which shall be done in a tabular form and shall be fixed on the reverse of the cover of the distribution box.
- (b) All the switchboards, DBs etc., shall be signwritten showing the circuit no and type of load etc.
- 4.22. UG cable of 1.1KV grade should be subject to pressure /insulation tests before and after laying the same. In case of unsatisfactory test, the cost of all

repair and replacements and all extra work of removal and relaying will have to be made good by the contractor at his own risk.

- 4.23. (a) Terminations of all the end connections of wires at Main boards/sub main boards, sub distribution boards will be done by crimping of lugs/ferrules/thimble as per EI internal specification 1994.
(b) No strand shall be cut and termination of wire shall be done with proper crimping tools without any extra payment.
- 4.24 The clearing of debris should be done by the contractor as soon as the work is completed.
- 4.25 Any damage done to the building, by the Contractor during the execution of work shall have to be made good at his cost and risk. If he does not do it himself within a reasonable time determined by the Engineer –in-charge then the same will be got done at his cost and risk departmentally after giving notice to him.
- 4.26 The bus bars shall be provided with heat shrinkable type insulation tapes/sleeves of respective colours of phases and neutral.
- 4.27 Suitable lugs shall be provided while terminating 8 SWG Copper / GI wire for earth continuity without any extra payment.
- 4.28 Knock out arrangement should be provided in the adopter/Junction/DB boxes for the entry of Conduits/cables.
- 4.29 Load balancing in three phases in all the sub main boards, sub distribution boards etc shall be planned before commencement of the wiring in consultation with the Engineer-in-charge and shall be strictly adhered to.
- 4.30 The lighting system shall be connected to IBMS and accordingly the contractor have to provide before the isolator of each switch board. Further extension from the switch board (SMB) is to be done through the IBMS contract.

TECHNICAL SPECIFICATION FOR SITC OF ELECTRICAL INSTALLATIONS & FANS, COMPOUND LIGHTING, PUMP SETS AND CONNECTED WORKS.

I) TECHNICAL SPECIFICATION FOR LT/ MV SWITCH BOARDS

1.1.0 SCOPE

This specification covers the technical requirements of manufacture, supply, installing, testing & commissioning L.T/MV Switch Boards complete with all accessories for efficient and trouble free operation at site.

1.2.0 STANDARDS

The equipment covered by this specification shall, unless otherwise stated, shall be designed, constructed and tested in accordance with the latest revisions of relevant Indian Standards/ Indian Standard Specification of CPWD and PWD Jharkhand Specifications (Internal) and shall conform to the regulations of local statutory Authorities.

1.3.0 CONSTRUCTION

- 1.3.1 The panel shall be metal-enclosed, freestanding compartmentalized type suitable for indoor installation. The panel shall be dust and vermin proof. The panel shall be of uniform overall height not exceeding 2300 mm.
- 1.3.2 The panel shall be fabricated out of 2mm thick CRCA mild steel structural sections. All the doors and covers shall be fabricated out of 1.60mm thickness CRCA mild steel sheet.
- 1.3.3 Each of the outgoing feeder terminals in the switch board, terminal are brought out to the cable chamber to form convenient connection of the outgoing cables.
- 1.3.4 (a) Incomers and outgoing feeders shall be provided with their own separate modules having separate doors, isolating switch of each units shall be mechanically interlocked with its respective doors.
(B) However a provision shall be made to defeat this interlock for testing the switch in its closed position.
- 1.3.5 (a) Each cable chamber shall have cable entry from bottom / Top and suitable removable gland plates shall be provided for this purpose.
(b) The cable chamber shall be provided with suitable supporting arrangement between the gland plate and terminals, in the middle.
(c) The cable chamber shall have a minimum width of 300 mm depending upon the outgoing cables.
- 1.3.6 Out going links from feeder shall be rigidly supported and suitably extended in cable chamber for easy cable connection.
- 1.3.7 (a) All retaining catches, screws and bolts for doors and covers shall be cadmium plated.
(b) Screws and bolts shall be captive.
(c) All covers, doors and joints shall be gasketed.
- 1.3.8 (a) Equipment to be mounted outside cubicles shall be flush mounted on cubicle door.
(b) No externally mounted equipment shall be mounted above 1.8m or below 0.3m above floor level.

- 1.3.9 (a) All panels and covers shall be properly fitted and square with the frames and holes in the panel correctly positioned.
- (b) The board shall be of totally enclosed design, completely dust proof and vermin proof.
- (c) Gaskets between all adjacent and beneath all covers shall be used to render the joint effectively dust proof.
- (d) Soft compressible gasket shall be used between all metal joints, doors and covers to prevent ingress of dust.
- 1.3.10 (a) All similar materials and removable parts of the switchboard shall be interchangeable.
- (b) The switchboards shall be fitted with the same family of switches of various ratings with a view to ensure uniformity of design, maintenance and replacements.
- (c) Separate and adequate compartments shall be provided for accommodating instruments, indicating lamps, control contractors and control fuses etc. These shall be accessible for testing and maintenance without any danger of accidental contact with live parts of the circuit breaker bus bar connections.
- 1.3.11 (a) A base channel of 75 mm x 40 mmx3mm thick hot rolled sheet steel channel section, painted black shall be provided to prevent corrosion of the sheet steel cubicles and facilitate cleaning of floors. For convenience of operation and cable termination, there shall be a gap of at least 150 mm between the floor level and bottom most unit.

2.7.0 BUSBARS

- 2.7.1 (a) The busbars shall be air insulated and made up of high conductivity, Aluminium.
- (b) All busbars shall be fully screened by means of PVC sleeves in their own compartment running throughout the length of the panel and also suitable allowance shall be made for bus expansion.
- (c) Suitable segregation shall be provided in between busbar chamber and adjoining compartments.
- (d) The busbar shall be PVC sleeved with colour strips of red, yellow, blue and black.
- (e) The busbars shall be TP and N, the section of the neutral bus being same size of the phase busbar.
- (f) The busbar shall be properly segregated, suitably braced with insulated supports (DMC/FRP/SMC) placed at appropriate (450mm) intervals to withstand the electromagnetic stresses during short circuit.
- (g) Minimum electrical clearances shall be maintained between phase, neutral and body as per standards.

2.8.0 INTERCONNECTION

- 2.8.1 (a) Switchboard shall be completely factory wired ready for connecting to equipment.
- (b) Power connection of the circuit shall be done by Aluminum flats or by adequate size of PVC insulated stranded copper wires.
- 2.8.2 (c) Control wiring shall be done by PVC insulated wires of minimum size 1.5 sq.mm copper.
- (d) All control wiring shall be fitted with identical identification ferrules at each end.
- (e) Not more than two connections shall be made at any one terminal. The wires shall be arranged and supported in such a manner that there shall be no strain on terminations.
- 2.8.3 (a) Suitable size and capacity of aluminium/ copper busbars shall be provided for interconnections between switches and main busbars for switches above 63Amps.
- (b) The interconnections of all the phases between the busbars and the incoming side of the switch cubicle shall be inaccessible when the doors of the controls are opened for removal of fuses etc.
- 2.8.4 For each and every tapping from the busbars, separate connections shall be made. No direct tappings from the busbar shall be made for any feeder without control and protection.
- 2.8.5 (a) The incoming and outgoing cable shall be properly identified and also the circuit to which it is connected on each outlet.
- (b) The size and number of runs of cables and load which it feeds shall be clearly written on the cable near the termination.

2.9.0 AIR CIRCUIT BREAKERS

2.9.1 General

- a. Air circuit breakers shall be of 3 poles / 4 poles and shall have over load, short Circuit and Earth Fault protections as specified in the schedule of work.
- b. Should be suitable for Isolation as per standard and shall have the Isolation between power circuit and Control circuit.
- c. Shall have Micro Processor trip-release.
- d. Should have facility of local fault identification (O/C, SC, E/F).

2.9.2 Construction

(a) General: It shall have / be

- ix) Motor wound spring closing mechanism wherever specified.
- x) Full draw-out type with indication for service, test and isolated positions.
- xi) Trip free mechanism.
- xii) Mechanical open, closed and spring charges indicator.

- xiii) Main contacts made up of copper.
- xiv) Magnetic blow out arc control device.
- xv) Facilities for pad locking.
- xvi) ACB shall have Line and Load Reversibility.
 - (b) The circuit breaker shall be fully draw out type. Suitable guides shall be provided to facilitate easy withdrawal of the trolley. All identical feeder compartments shall be inter-changeable.
 - (c) All current carrying contacts of the breaker shall be silver plated. Contacts subjected to arcing shall be tipped with suitable arc resisting material.
 - (d) Shall have facility of O/C Pre-Trip alarm at set current.
 - (e) The contacts shall be self-aligning, plug-in type, designed to ensure adequate contact pressure on the main busbars requiring minimum maintenance.

2.9.3 Operating Mechanism

- (a) The operating mechanism shall be trip-free.
- (b) Failure of spring, vibrations or shocks shall not cause unintended operation of breaker or prevent intended tripping operation.
- (c) Closing of breakers shall be prevented unless the spring is fully charged.

2.9.4 Interlocks

- (a) The breaker shall be provided with all necessary interlocks to prevent inadvertent operations and to ensure safety of operating personnel and also the equipment.
- (b) It shall not be possible to push in a drawn out breaker in closed condition or withdraw a breaker in closed condition.
- (c) Compartment doors shall be interlocked against opening when breaker is in 'Closed' condition.
- (d) It shall not be possible to operate the breaker in intermediate position while inserting or withdrawing a circuit breaker.

- 2.9.5 The frame of the circuit breaker should be positively earthed, when the breaker is racked in back to the cubicle.

2.7.0 MOULDED CASE CIRCUIT BREAKERS

2.7.2 General:

- vi. MCCB shall have Thermal Magnetic release up to 250A & shall have Micro – Processor releases of above 250A.
- vii. Micro processor releases should be EMC (electronic module control) compatibility.

- viii. Should have the facility to change the setting in on condition.
 - ix. Shall have the Isolation between power circuit and Control circuit.
 - x. Shall have front door handles.
- 2.7.2.** (a) The MCCB shall comprise of switching mechanism, contact system, arc extinguishing device and the tripping unit all mounted inside a molded case.
- (b) The MCCB shall be provided with field settable over load protection and S/C protection.
- 2.7.3** (a) MCCB shall employ quick make and quick break switching mechanism independent of the speed of operation of the operating handle.
- (b) The operating mechanism also be trip free. The operating handle shall indicate the position of the MCCB in ON / OFF / TRIPPED. The operating handle shall have provision for padlocking.
- (c) Door interlocking shall be provided.

2.7.5 CHANGEOVER SYSTEM :

- iii. MCCBS should be electrically and mechanically interlocked as per the drawings and schedule of work.
- iv. Mechanical interlock should be done with MCCB fitted in the mechanical frame with interlock lever. Frame should be fitted in either direction (vertical or horizontal)

2.8.0 CABLE COMPARTMENT

- iii. **A full height compartment shall be provided for easy terminations of all incoming and outgoing cables entering either from top or from bottom. Adequate supports shall be provided for the cable wherever necessary.**
- iv. The cable compartment shall have its own-hinged cover that can be removed for easy access during cabling.

2.9.0 CONTACTORS

- v. Contactor shall be of electromagnetic type rated for uninterrupted duty unless otherwise specified and also suitable for capacitor duty.
- vi. The main contacts shall be of silver or silver alloy.
- vii. Each contactor shall be provided with 2 N/O and N/C aux. contacts.
- viii. Contactor coil rating shall be minimum pick up of 85% of rated voltage and minimum drop out of 75% rated voltage.

2.10.0 PUSH BUTTONS

- (a) Push buttons shall be generally shrouded.
- (b) Each push button shall be provided with 1 N/O and 1 N/C aux. contacts. "Stop" push button shall have, 'stay-put' feature.

2.11.0 INDICATION

2.11.1 Indication lamps shall be provided in each feeder with indication 'ON' or 'OFF' under trip.

2.11.2 Potential free contact shall be provided for monitoring ON / OFF / Trip status from remote.

2.12.0 SPACE HEATERS

Anti condensation space heaters, with thermostat suitable for 230 V, 1 Ph supply along with a switch / fuse/indication lamps shall be provided in each panel.

2.13.0 CONTROL SWITCHES

- (a) A general purpose control switch shall be provided for selection of "Auto" & "Manual".
- (b) The switch shall be provided with engraving plate in the front with "Auto", Manual" & "Off" inscription.
- (c) This switch shall be normally of the fixed-control bar type heavy duty unit.

2.14.0 MEASURING INSTRUMENTS

- (a) Ammeters and Voltmeters shall be of digital type. They shall be industrial grade and shall have means of zero adjustment from the front without dismantling them.
- (b) They shall be capable of carrying the normal full load current (via CTS) and shall not be damaged by effects of rated fault current.
- (c) The instruments shall have an accuracy class of 1.0.

2.15.0 CONTROL WIRING

2.15.1 Panel shall be supplied with all internal wiring comprising of PVC insulated 1.1 KV grade, multi stranded flexible copper conductor of 1.5 Sq.mm cross section.

2.15.2 Wiring associated with a particular phase shall be the colour of that phase viz. Red / Yellow, or Blue, wiring associated with earthing shall be with green colour insulation and for neutral it shall be with black colour insulation.

2.15.3 Wiring shall be neatly laid and run on insulated cleats of limited compression type insulated straps.

2.15.4 All cables shall have crimped terminations and shall be identified by means of glossy plastic ferrules at both ends, showing the wire number as indicated in the schematic diagrams. The ferrules shall be indelibly marked.

2.15.5 Wiring to items mounted on hinged doors or wiring that is subject to movement, shall run in helical binding. The binding shall be securely anchored at both ends and sufficient slack provided to prevent any strain being imposed on wiring.

2.16.0 EARTHING

- 2.16.1 All the metal parts of all equipment supplied within the panel (including doors and gland plates) other than those forming part of all electric circuit, shall be connected by means of two independent earth conductors to continuous copper earth bar of size 25 x 5 mm running along the full length of the panel.
- 2.16.2 The panel shall be provided with two brass earthing stud terminals, with suitable nuts, washers etc. for connection to ground bus.

2.17.0 TERMINAL BLOCK

- 2.17.1 Terminal blocks shall preferably be grouped according to circuit functions and each terminal block group shall have atleast 10% spare terminals. Terminal blocks for control circuit shall be of 650V grade with contact ratings not less than 10A and stud/clamp type.
- 2.17.2 Not more than two wires shall be connected to any terminal block.

2.18.0 LABELS

- 2.18.1 Labels shall be provided to describe the duty of or otherwise identify every Instrument, or other item of equipment mounted internally and externally. Switch positions shall be fully identified. Wording shall be clear, concise and unambiguous.
- 2.18.2 Each label shall be permanently secured to the panel surface below the item to which it refers.
- 2.18.3 The labels shall be engraved plastic with white letters in black background.
- 2.18.4 In addition to component labels, each cubicle door shall bear a large identification labels and the panel shall include large, prominent overall identification label.

2.19.0 PAINTING

- 2.19.1 Care shall be taken in workmanship and selection of materials to prevent the occurrence of any form of damage or corrosion due to damp or highly humid conditions.
- 2.19.2 The panel shall be prepared, primed, filled and painted to the highest standards. All items shall be cleaned and deburred after fabrication and welding is complete. External surfaces shall be filled and rubbed down as necessary to obtain a perfectly flat smooth surface free from blemishes and imperfections and the whole shall be Powder Coated with Epoxy paint and the shade shall be as per approved Engineer-in-charge .
- 2.19.3 The panels shall be fabricated at such work shops where the following facilities are available and the panels are subject to the following processes. Necessary certificate to this effect shall be submitted.
- Sand blasting
 - Pretreatment (Seven tank process)
 - Spray booth

Heating in the oven for all sizes of panels.
Heat shrinking of PVC sleeves.

II) SPECIFICATION FOR CABLE LAYING

- 3.1.1 The work shall be carried out strictly in accordance with general Indian Standard Specification of CPWD and PWD Jharkhand Specifications for electrical works {Part 2 External} 1994 amended upto date.
- 3.1.2 All cables shall be laid in ground, trenches & or on walls, trays as may be specified and as per schematic diagram.
- 3.1.3 Cables shall be laid in the routes marked in the drawings. Where the route is not marked, the contractor shall mark it out on the drawings and also on the site and obtain the approval of the Engineer-in-charge before laying the cable.
- 3.1.4. All cables shall be clamped properly when laid along the wall /ceiling /cable tray. Cables laid in built-up trenches shall be on steel supports. Aluminium identification tags shall be provided at every 20 m.
- 3.1.5. Cables shall be bent to a radius not less than 12 times the overall diameter of the cable, or in accordance with the manufacturer's recommendations whichever is higher.
- 3.1.6. Cables shall be identified at end terminations indicating the feeder number and size and no. of runs and the Panel / Distribution Board from where it is being laid.
- 3.1.9 (a) For Cables laid in soil, the cable route shall be parallel or perpendicular to roadways, walls, etc.,
(d) Cables shall be laid in an excavated, graded trench, over sand cushion to provide protection against abrasion.
(e) Width of excavated trenches shall be as per drawings/ department specifications.
- | <u>Width of trench</u> | <u>Height of trench</u> | <u>Sand cushioning</u> | |
|------------------------|-------------------------|------------------------|-------|
| i. For MV cable | 350mm | 750mm | 250mm |
| ii. For HT cable | 350mm | 1200mm | 250mm |
- 3.1.10 The cables laid in the excavated trenches shall be protected with bricks over the cable. The bricks should be laid laterally to the trench.
- 3.1.9 The cables laid in buried underground trench shall be provided with cable markers at every 10 metres.
- 3.1.10 (a) All cable terminations for conductors' upto 4 sq.mm may be insertion type and all higher sizes shall have compression lugs.
(b) Cable terminations shall have necessary brass glands.
- 3.1.15. Wherever cables pass through floor or through wall openings, it shall be taken through HDPE PVC/GI sleeves. The open ends of the sleeves shall be sealed by cold setting compound after cables are pulled through them to prevent entry of vermin and ingress of water.

- 3.1.16. In making connection on switches and other terminals no strand of conductor shall be cut to facilitate termination.
- 3.1.16. Cable armouring shall be earthed at both ends.
- 3.1.17. The cable shall be as per the relevant IS amended from time to time, Test certificate should be submitted by the contractor for the cables supplied by him.
- 3.1.18. The contractor at his own cost and risk shall arrange all necessary tools & plants. The contractor will be held responsible for any damage to the building or equipment at the time execution of work.

TESTING:

- 3.1.17. Testing of complete cable installation shall be done as provided in general Specification for electrical works (Part 2 External) 1994/1995 amended up to date.
- 3.1.18. MV cables shall be tested after installation with a 500 V Muggger and the following readings established.
- 1) Continuity on all phases
 - 2) Insulation Resistance (a) between conductors
(b) All conductors and ground

All test readings shall be recorded in the separate book and the same to be handed over to the Engineer-in-charge.

III) SPECIFICATION FOR THE WORK OF PROVIDING EI&FANS

- 4.2 The works shall be done as per current JSOR Specifications for electrical works (Internal, External) as amended from time to time and Indian Electricity rules as amended up to date.
- 4.4. The work shall be supervised by qualified Electrical staff.
- 4.5. The layout of the work will be given by Engineer-in-charge or his duly authorized representative at site of work.
- 4.7 The following wiring shall be done on separate conduits.
- f. Power plug wiring
 - g. Light and fan wiring.
 - h. Emergency Light wiring(DC/AC supply)
 - i. Telephone/LAN Wiring
 - j. AC units wiring
- 4.8 The earthing has to be done in the presence of Engineer-in-charge or his authorized representative.
- 4.9
- a. The MS conduit shall be of IS marked, stove enameled.
 - d. The conduits shall be delivered to site in original bundles and each length shall bear the label of the manufacturer.
 - e. The materials brought at site shall be with proper challan with quantity mentioned on it.

- 4.7 a. The makes of material have been indicated in the list of approved makes. No other make will be acceptable.
- b. The material to be used in the work shall be got approved from the Engineer-in-charge before its use at site. The Engineer-in-charge shall reserve the right to instruct the contractor to remove the material which, in his opinion, is not as per specifications.
- 4.9 The no. of light points fed from the AC / DC supply shall not exceed 10 points or 800 watts per Circuits, whichever is less.
- 4.11 All the Copper wires shall be multi-stranded conductor. Termination of multi-stranded conductors shall be done using crimping type thimbles at both the ends. Nothing extra shall be paid for the same
- 4.12 All hardware material such as nuts/bolts /screws/washers etc. to be used in the work shall be zinc/cadmium galvanized iron.
- 4.11 a. Extra module 1No. for switch boxes where 4Nos. and above 4Nos. of switches shall be provided in the modular switch box for future use without any extra cost.
- b. The extra modules shall be provided with blanking plates without any extra cost.
- 4.19 Modular type switches/sockets/telephone outlets to be provided shall be as per approved makes.
- 4.20 Different categories of conduit/ runs/ face plates catering for different types of electrical wiring as mentioned in clause (4.4) above shall be painted with different colour each signifying a particular category mentioned, so as to avoid mixing of various circuits and their wiring and nothing extra will be paid for this.
- 4.21 a. The outer surface of conduits including all bends, unions, tees, junction boxes etc. forming part of the conduit system, shall be adequately protected against rust.
- b. The conduits are to be painted with 2 coats of red oxide paint before they are fixed.
- c. All bare threaded portions shall be treated with anticorrosive preservative (or) approved plastic compound.
- 4.22 (a) At the time of laying conduit pipe in the slab in recess, the contractor will keep fish wires of 16 SWG GI wire throughout conduit pipe and will have to take special care so that the conduits do not pass through air-conditioning ducts, grills, beams etc.
- (b) If any, such necessity is foreseen special written permission of the Engineer-in-charge will be obtained before such work is carried out.
- (c) In case of failure, to do as above, the contractor will not be paid on this account and the work has to be redone by the contractor as per direction of Engineer-in-charge.
- 4.23 (a) The conduits are to be concealed in the walls before the walls are plastered and work is to be done in coordination with building work. Any

damage thus done will have to be made good by the contractor at his own risk and cost.

- (c) The conduit pipe should mechanically and electrically be continuous.
- 4.24 The circuit wiring is to be meticulously planned and carried out in the most economical manner avoiding columns crossing etc.
- 4.25 a. The point wiring will be extended up to the fitting/ceiling rose etc. directly without provision of any termination arrangement in between.
c. The wiring from the end point up to the fixture shall be considered to be included in the respective item of installation of that fixture. Nothing extra shall be paid for the same.
- 4.24. Wherever it is not possible to provide rigid conduits, flexible metallic pipe shall be provided for running the wires. However, such arrangement has to be kept to the barest minimum and to be done only with the prior approval of Engineer-in-charge.
- 4.25. All fittings/fans will be earthed with 1.5 Sq.mm PVC insulated multi strand copper conductor.
- 4.26. (a) All the distribution board, sub-main board and their complete fitting shall be signwritten clearly indicating the number of distribution board, the type of load it is serving and the number of circuit contained in the distribution box which shall be done in a tabular form and shall be fixed on the reverse of the cover of the distribution box.
(b) All the switchboards, DBs etc., shall be signwritten showing the circuit no and type of load etc.
- 4.27. UG cable of 1.1KV grade should be subject to pressure /insulation tests before and after laying the same. In case of unsatisfactory test, the cost of all repair and replacements and all extra work of removal and relaying will have to be made good by the contractor at his own risk.
- 4.28. (a) Terminations of all the end connections of wires at Main boards/sub main boards, sub distribution boards will be done by crimping of lugs/ferrules/thimble as per EI internal specification 1994.
(b) No strand shall be cut and termination of wire shall be done with proper crimping tools without any extra payment.
- 4.31 The clearing of debris should be done by the contractor as soon as the work is completed.
- 4.32 Any damage done to the building, by the Contractor during the execution of work shall have to be made good at his cost and risk. If he does not do it himself within a reasonable time determined by the Engineer -in-charge then the same will be got done at his cost and risk departmentally after giving notice to him.
- 4.33 The bus bars shall be provided with heat shrinkable type insulation tapes/sleeves of respective colours of phases and neutral.
- 4.34 Suitable lugs shall be provided while terminating 8 SWG Copper / GI wire for earth continuity without any extra payment.

- 4.35 Knock out arrangement should be provided in the adopter/Junction/DB boxes for the entry of Conduits/cables.
- 4.36 Load balancing in three phases in all the sub main boards, sub distribution boards etc shall be planned before commencement of the wiring in consultation with the Engineer-in-charge and shall be strictly adhered to.
- 4.37 The lighting system shall be connected to IBMS and accordingly the contactor have to be provide before the isolator of each switch board. Further extension from the switch board (SMB) is to be done through the IBMS contract.

IV GENERAL AND TECHNICAL SPECIFICATION FOR INTERNAL ELECTRICAL INSTALLATION

5.1.0 SCOPE

The general technical requirements and specification of the various components in internal electrical Installation works.

5.2.1 TERMINOLOGY

- 5.2.1.1 The definition of terms shall be in accordance with IS: 732-1989 (Indian Standard Code of Practice for Electrical Wiring), except for the definitions of point, circuit, and sub main wiring, which are defined in clauses 5.2.2, 5.4.1 and 5.4.2 hereunder.
- 5.2.1.2 The conventional signs and symbols for technical work as per the Indian Standard Specification of CPWD and PWD Jharkhand Specifications.

5.2.2 POINT WIRING

5.2.2.1 Definition

A point (other than socket outlet point) shall include all work necessary in complete wiring to the following outlets from the controlling switch or MCB. The scope of wiring for a point shall, however, include the wiring work necessary in tapping from another point in the same distribution circuit.

- (a) Ceiling rose or connector (in the case of points for ceiling / exhaust fan points, prewired light fittings, and call bells).
- (b) Ceiling rose (in the case of pendants except stiff pendants).
- (c) Back plate (in the case of stiff pendants).
- (d) Lamp holder (in the case of goose neck type wall brackets, batten holders and fittings which are not prewired).

Note: - In the case of call bell points, the words “from the controlling switch or MCB” shall be read as “from the ceiling rose meant for connection to bell push”.

5.2.2.2 Scope

Following shall be deemed to be included in point wiring.

- (a) Conduit / casing and capping / batten as the case may be, accessories for the same and wiring cables between the switch box and the point outlet.
- (b) All fixing accessories such as clips, nails, screws, Phil plug, rawl plug etc. as required.
- (c) Metal switch boxes for control switches, regulators, sockets etc, recessed or surface type, and modular top plate sheet covers over the same.
- (d) Outlet boxes, junction boxes, pull-through boxes etc, but excluding metal boxes if any, provided with switch boards for loose wires / conduit terminations.
- (e) 3 pin or 6 pin socket, ceiling rose or connector as required. (2 pin and 5 pin socket outlet shall not be permitted).
- (f) Connections to ceiling rose, connector, socket outlet, lamp holder, switch etc.
- (g) Interconnecting wiring between points on the same circuit, in the same switch box or from another.
- (h) Protective (loop earthing) conductor from SDB to switch board and one metallic switch box to another in the distribution circuits, and for socket outlets on switch board. (The length of protective conductor run along with the submains is excluded from the scope of points).
- (i) Bushed conduit or GI/MS piping where wiring cables pass through wall etc.
- (j) Circuit wiring from SDB to switch box.

5.3 Measurement

5.3.1 Point Wiring (other than socket outlet points)

- (i) Unless and otherwise specified, there shall be no linear measurement for point wiring for light points, fan points, exhaust fan points and call bell points. These shall be measured on unit basis by counting, and classified as laid down in 5.3.2.
- (ii) No separate measurement will be made for interconnections between points in the same distribution circuit and for the circuit protective (loop earthing) conductors between metallic switch boxes.

5.3.2 Classification

Points measured under 5.3.1 on unit basis shall be classified as under according to the type of building.

(i) Non Residential buildings:-

Group `C', for all types of non-residential buildings such as offices, hospitals, laboratories, educational institutions, libraries etc.

5.3.3. Point wiring for socket outlet points

- (i) The light plug 5A/6A point (except on switch board point) and power 15A/16A point wiring shall be measured on linear basis, from the respective tapping point of live cable, namely, switch box, another socket outlet point, or the sub distribution board as the case may be, up to the socket outlet.

- (ii) The metal box with cover, switch socket outlet and other accessories shall be measured and paid as a separate item.
- (iii) The power point outlet may be 15A/5A or 16A/6A six pin socket outlet, where so specified in the tender documents.

5.3.4 Group control points wiring

- a. In the case of points with more than one point controlled by the same switch, such points shall be measured, as per the schedule of work and measured as one set.
- b. No recovery shall be made for non-provision of more than one switch in such cases.

5.3.5 Twin control light points wiring

- (i) A light point controlled by two numbers of two way switches shall be measured as two points from the fitting to the switches on either side and classified according to 5.3.2.
- (ii) No recovery shall be made for non-provision of more than one ceiling rose or connector in such cases.

5.3.6 Multiple controlled call bell points wiring

- (i) In the case of call bell points with a single call bell outlet, controlled from more than one place, the points shall be measured in parts i.e., (a) from the call bell outlet to one of the nearest ceiling roses meant for connection to bell push, treated as one point and classified according to 5.3.2 and, (b) from that ceiling rose to the next one and so on, shall be treated as separate point(s) and classified according to 5.3.2.
- (ii) No recovery shall be made for non-provision of more than one ceiling rose or connector for connection to call bell in such cases.

5.4 CIRCUIT AND SUBMAIN WIRING

5.4.1 Circuit wiring

Circuit wiring shall mean the wiring from the distribution board upto the tapping point for the nearest first point of that distribution circuit, viz. upto the nearest first switch box. Cast of the same shall be included in point wiring itself. No extra payment shall be made.

5.4.2 Submain wiring

Submain wiring shall mean the wiring from Switch board to Distribution board

5.4.3 Measurement of submain wiring

- a. Submain wiring shall be measured on linear basis along the run of the wiring.
- b. The measurement shall include all lengths from end to end of wood batten or

conduit or casing and capping as the case may be, exclusive of interconnections inside the switch board etc.

- c. The increase on account of diversion or slackness shall not be included in the measurement.
- d. When wires of different submains are grouped in a single conduit / casing and capping, the same shall be measured on linear basis depending on the actual number and sizes of wires run.

5.5 OTHER WIRING WORKS

- (i) Except as specified above for point wiring and submain wiring, other types of wiring shall be measured separately on linear basis along the run of wiring depending on the actual number and sizes of wires run.

5.6 SYSTEM OF DISTRIBUTION AND WIRING

5.6.1 Control at the point of entry of supply

There shall be a circuit breaker on each live conductor of the supply mains at the point of entry.

5.6.2 Distribution

- (i) (a) The wiring shall be done on a distribution system through main and / or branch distribution boards.
(b). The system design as well as the locations of boards shall be as specified by the Engineer-in-charge.
- (ii) (a). Main distribution board shall be controlled by a circuit breaker.
(b). Each outgoing circuit shall be controlled by a circuit breaker on the phase or live conductor (as in the case of a TPDB).
- (iii) (a) The branch distribution board shall be controlled by a circuit breaker.
(b) Each outgoing circuit shall be provided with a miniature circuit breaker (MCB) of specified rating on the phase or live conductor.
- (iv) (a) Triple pole distribution boards shall not be used for final circuit distribution, unless specific approval of the Engineer-in-charge is obtained.
(b) In such special cases the triple pole distribution boards shall be of MCB type only.
- (v) The loads of the circuits shall be divided, as far as possible, evenly between the number of ways of the distribution boards, leaving at least one spare circuit for future extension.
- (vi) The neutral conductors (incoming and outgoing) shall be connected to a common link (multiway connector) in the distribution board and be capable of being disconnected individually for testing purposes.
- (vii) Power' wiring shall be kept separate and distinct from 'Lighting' wiring, from the level of circuits i.e. beyond the branch distribution boards.

5.6.3 Balancing of Circuits

The balancing of circuits in three wire or poly phase installations shall be arranged before hand to the satisfaction of the engineer-in-charge.

5.6.4 Wiring system

- (i) (a) Unless and otherwise specified in the tender documents, wiring shall be done only by the "Looping system".
(b) Phase or live conductors shall be looped at the switch boxes and neutral conductors at the point outlets.
- (ii) Where "Joint box system" is specified in the tender documents all joints in the conductors shall be made by means of approved mechanical connectors in suitable and approved junction boxes.
- (iii) (a) Lights, fans and call bells shall be wired in the 'lighting' circuits.
(b) 15A/16A socket outlets and other power outlets shall be wired in the 'power' circuits.
(c) 5A /6A socket outlets shall be wired in the 'lighting' circuits in non residential buildings.
- (iv) The wiring throughout the installation shall be such that there is no break in the neutral wire except in the form of a circuit breaker.

5.6.5 Run of Wiring

- (i) The type of wiring shall be as specified in tender documents, namely wood batten, casing and capping, or conduit.
- (ii) Surface wiring shall run, as far as possible, along the walls and ceiling so as to be easily accessible for inspection.
- (iii) In no case, the open wiring shall be run above the false ceiling without the approval of Engineer-in-charge.
- (iv) In all types of wiring, due consideration shall be given for neatness, good appearances.

5.6.6 Passing through walls or floors

- (i) (a) When wiring cables are to pass through a wall, these shall be taken through a protection (steel/GI) pipe tube of suitable size such that they pass through in a straight line without twist or cross in them on either end of such holes.
(b) The ends of metallic pipe shall be neatly bushed with PVC or other approved material.
- (ii) Where a wall pipe passes outside a building so as to be exposed to weather, the outer end shall be bell mouthed and turned downwards and properly bushed on the open end.
- (iii) All floor openings for carrying any wiring shall be suitably sealed after installation.

5.6.7 Joints in wiring

- (i) No bare conductor in phase and / or neutral or twisted joints in phase, neutral, and/or protective conductors in wiring shall be permitted.
- (ii) There shall be no joints in the through-runs of cables. If the length of final circuit or submain is more than the length of a standard coil, thus necessitating a through joint, such joints shall be made by means of approved mechanical connectors in suitable junction boxes.
- (iii) Termination of multi stranded conductors shall be done using suitable crimping type thimbles.

5.7 RATINGS OF OUTLETS (to be adopted for design)

- (i) Incandescent lamps in residential/non residential buildings shall be rated at 60W and 100W respectively.
- (ii) Ceiling fans shall be rated at 60W. Exhaust fan, fluorescent tubes, compact fluorescent tubes, HPMV lamps, HPSV lamps etc. shall be rated according to their capacity. Control gear losses shall be also considered as applicable.
- (iii) 5A/6A and 15A/16A socket outlet points shall be rated at 100W and 1000W respectively, unless the actual values of loads are specified.

5.8 CAPACITY OF CIRCUITS :

- (i) "Lighting" circuit shall not have more than a total of 10 points of light, fan and socket outlets, or a total connected load of 800W, whichever is less.
- (ii) (a) "Power" circuit shall be designed with only one outlet per circuit in nonresidential buildings.
 - (b) The circuit shall be designed based on the load. Where not specified, the load shall be taken as 1 KW per outlet.
- (iii) Load more than 1KW shall be controlled by an isolator or miniature circuit breaker.

5.9 CONFORMITY TO IE ACT, IE RULES, AND STANDARDS

- (i) (a) All electrical works shall be carried out in accordance with the provisions of Indian Electricity Act, 1910 and Indian Electricity Rules, 1956 amended upto date.

The works shall also conform to relevant Indian Standard Codes of Practice (COP) for the type of work involved.
- (ii) In all electrical installation works, relevant safety codes of practice shall be followed. Guidelines on safety procedure outlined in annexure "A" should be adopted.

5.10 GENERAL REQUIREMENTS OF COMPONENTS

5.10.1 Quality of materials

- (a) All materials and equipments supplied by the contractor shall be new.
- (b) They shall be of such design, size and material as to satisfactorily function under the rated conditions of operation and to withstand the environmental conditions at site.

5.10.2 Ratings of components

- a. All components in a wiring installation shall be of appropriate ratings of voltage, current, and frequency, as required at the respective sections of the electrical installation in which they are used.
- b. All conductors, switches and accessories shall be of such size as to be capable of carrying the maximum current which will normally flow through them, without their respective ratings being exceeded.

5.10.3 Conformity to Standards

- (a) All components shall conform to relevant Indian Standard Specification, wherever existing. However, for conduits, wiring cables, piano / tumbler switches and socket outlets, ISI marked materials shall only be permitted.
- (b) Indian Standards is given. These Indian Standards, including amendments or revisions thereof up to the date of tender acceptance, shall be applicable.

5.10.4 Interchangeability

Similar parts of all switches, lamp holders, distribution MCB boards, switch gears, ceiling roses, brackets, pendants, fans and all other fittings of the same type shall be interchangeable in each installation.

5.10.5 Categorization of components

- (a) Makes of certain items of materials are categorized from time to time by the Department and included in tender documents shall only be used in the work.
- (b) For items of materials for which makes are approved by the Department, only such approved makes shall be permitted in the work.

5.10.6 Special risks

Special forms of construction such as flame proof enclosures shall be adopted wherever indicated in the tender documents.

5.11 CABLES

5.11.1 Wiring cables

- (i) (a) Conductors of wiring cables (other than flexible cables) shall be of copper, as specified.

- (ii) The smallest size of conductor for 'lighting' circuits shall have a nominal cross sectional area of not less than 1.5 Sq.mm. The minimum size of conductor for 'power' wiring shall be 4 sq.mm.
- (iii) Aluminium conductor shall not be used in wiring cables up to and including 6 Sq.mm size.

5.11.2 Flexible cables

- (i) Conductor of flexible cables shall be of copper. The minimum cross sectional area of conductor for flexible cable shall be 14 / 0.193 mm).
- (ii) Only 3 core flexible cables shall be used for connecting single phase appliances.
- (iii) Unless the flexible cables are mechanically protected by armour, or tough rubber, or PVC sheath, these shall not be used in workshops and other places where they are liable to mechanical damage.
- (iv) Flexible cable connection to bell push from ceiling rose shall be taken through steel conduit / metallic casing and capping.

5.12 WIRING ACCESSORIES

5.12.1 Control switches for points

- (i) Control switches (single pole switches) carrying not more than 6A/16A may be of modular piano type, as specified, and the switch shall be "ON" when the knob is down.
- (ii) Control switches of 15A/16A rating may preferably be only of modular piano type. If, however, piano type switch is used for controlling a socket outlet, the switch and socket outlet shall be separate units.
- (iii) The type and current rating of switch controlling a group of points, or discharge lamps, or a single large load, shall be suitable for the respective loads and as specified in the tender documents.
- (iv) (a) Power (15A/16A) outlets shall be controlled by single pole modular piano type switches or by MCB's, where specified.
 - (b) Only MCB's shall be used for controlling industrial type socket outlets, and power outlets above 1 KW.
- (v) (a) Control switch shall be placed only in the live conductor of the circuit.
 - (c) No single pole switch or fuse shall be inserted in the protective (earth) conductor, or earthed neutral conductor of the circuit.

5.12.2 Socket outlets

- (i) (a) Socket outlets shall be of the same type, namely, piano type as their control switches. These shall be rated either for 5A/6A.
 - (b) Combined 5A/15A, or 6A/16A six pin socket outlet may be provided in 'power' circuits only where specified.

- (ii) (a) In an earthed system of supply, socket outlets and plugs shall only be of 3 pin type; the third pin shall be connected to earth through protective (loop earthing conductor). 2 pin or 5 pin sockets shall not be permitted to be used.
(b) Conductors connecting electrical appliances with socket outlets shall be of flexible twin cord with an earthing cord, which shall be secured by connecting between the earth terminal of plug and the metallic body of the electrical appliance.
- (iii) Sockets for the power outlets of rating above 1KW shall be of industrial type with associated plug top and controlling MCB.
- (iv) Where specified, shutter type (interlocking type) of sockets shall be used.
- (v) A socket outlet shall not embody fuse terminal as integral part of it. But the fuse may be embodied in plug, in which case the plug shall be non-reversible and shall be so arranged and connected that the fuse is connected to phase, or live conductor or the non earthed conductor of the circuit.
- (vi) Every socket outlet shall be controlled by a switch or MCB, as specified. The control switch/MCB shall be connected on the 'live' side of the line.
- (vii) Outlet boxes for socket outlet (both 15A/16A and 5A/6A) points shall be of modular type only.
- (viii) 5A/6A and 15A/16A socket outlets shall be installed at the following positions, unless otherwise specified.
- (ix) Non residential buildings – 23cm above floor level.
 - (a) Kitchen / Pantry -23cm above working platform and away from the likely positions of stove and sink.
 - (b) Bathroom – No socket outlet is permitted for connecting a portable appliance thereto. MCB switch may be provided above 2.1m for fixed appliances, and at least 1m away from shower.
 - (c) Rooms in residences -23cm above floor level, or any other level in special cases as desired by the Engineer-in-charge.

5.12.3 Switch box covers

Modular plate cover sheets of approved shade shall be used for switch box covers.

Note: Specification for switch boxes are covered in the various types of wiring.

5.12.4 Ceiling rose

- (i) A ceiling rose shall not be used on a circuit, the voltage of which normally exceeds 250V.
- (ii) Only one flexible cord shall be connected to a ceiling rose. Specially designed ceiling roses shall be used for multiple pendants.
- (iii) A ceiling rose shall not embody fuse terminal as an integral part of it.

5.12.5 Lamp holders

- (i) (a) Lamp holders may be of batten, angle, pendant or bracket holder type as required.
- (b) The lamp holder shall be made of brass and shall be rigid enough to maintain shape on application of a nominal external pressure.
- (c) There should be sufficient threading for fixing the base to the lamp holder part so that they do not open out during attention to the lamp or shade.
- (ii) All lamp holders shall be provided with shade carriers.

5.13 FITTINGS

5.13.1 Types

The type of fittings shall be as specified in tender documents.

5.13.2 Indoor type fittings

- (ii) (a) Where conductors are required to be drawn through tube or channel leading to the fitting, the tube or channel must be free from sharp angles or projecting edge,
- (b) The tube or channel shall be of such size as will enable them to be wired with the conductors used for the final circuit without removing the braiding or sheathing.
- (c) As far as possible all such tubes or channels should be of sufficient size to permit looping back.
- (iii) (a) Wires used within prewired fittings shall be flexible with PVC insulation and 14 /0.193m (minimum) copper conductors.
- (b) The leads shall be terminated on built-in terminal block, ceiling rose or connector, as required.
- (iv) (a) Fittings using discharge lamps shall be complete with power factor correction capacitors, either integrally or externally.
- (b) An earth terminal with suitable marking shall be provided for each fitting for discharge lamps.
- (v) Fittings shall be installed such that the lamp is at a height of 2.5m above floor level, unless otherwise directed by the Engineer-in-charge.

5.13.3 Bulk head fittings

Bulk head fittings shall be of cast iron / cast aluminium body, suitably painted white inside and grey outside, complete with heat resistant glass cover, gasket, IC lamp holder for 100W incandescent lamp, and wire guard.

5.13.4 Outdoor fittings

- (a) Fittings for outdoor use shall be of appropriate (weather proof) design so as to effectively prevent the entry of moisture.

- (b) Flexible cord conductors and cord grip lamp holders must not be used where exposed to weather.

5.14 SWITCHGEAR AND CONTROL GEAR – General aspects

- (i) All items of switchgear and distribution boards (DBs) shall be of metal clad type, except those forming part of cubicle type switch boards, in which case the board design shall be such as not to permit direct contact.
- (ii) The types, ratings and/or categories of switchgear and protective gear shall be as specified in the tender schedule of work.
- (iii) RCDs (ELCBs) where specified, shall conform to the requirements of current rating, fault rating, single phase or three phase configuration and sensitivity laid down in the tender documents.
- (iv) (a) While each outgoing way of distribution board (DB) shall be of miniature circuit breaker (MCB) as specified, and of suitable rating on the phase conductor.
(b) The corresponding earthed neutral conductor shall be connected to a common neutral terminal block and shall be capable of being disconnected individually for testing purposes.
- (v) Independent earth terminal block**
Every distribution board (single phase as well as 3 phase) shall have an earth terminal block identical to, but independent from neutral terminal block, to enable termination of protective (loop earthing) conductors (incoming as well as outgoings) individually by screwed connection and without twisting.
- (vi) Earthing terminal (1 for single phase and 2 for 3 phase) shall be provided on the metal cladding of switches and DBs for body earthing. These shall be suitably marked.
- (vii) Knock out holes, with or without end plates as per standard design of manufacturers, shall be provided in the metal cladding of switches and DBs for termination of conduits / cables.
- (viii) Each distribution board shall be provided with a circuit list giving details of each circuit which it controls and the current rating of the circuit, and the size of the fuse element.

5.15 MCB TYPE DISTRIBUTION BOARDS (MCBDB)

- (i) (a) MCBDB's may be of single phase suitable for feeding single phase loads, or 3 phase suitable for feeding single phase as well as 3 phase loads, as specified.
(b) These shall be complete with accessories, including MCBs, which shall be specified as in the tender documents.
- (ii) The current ratings and the number of ways shall be as specified. Blanking plates shall be provided to close unused ways.

- (iii) DB with integral incomer
 - (a) Where it is proposed to install the controlling MCB/MCB type isolator / both, the total number of outgoing MCBs. Since the total number of ways are fixed in MCBDBs. Busbars in such units shall also be provided as per the schedule of work.
 - (b) The interconnections shall be done between the incomer and outgoing as part of the DB in the works.
- (iv) MCBDB's shall be of surface/flush mounting pattern according to the requirement of their location, and shall be suitable to accommodate MCB's and MCB type isolators and RCD (ELCB) at incoming in single pole or multi pole configuration, as required.
- (v) MCBDB's shall be dust and vermin proof and shall be fabricated out of CRCA sheet steel, 1.6mm thick, with stove enamelled paint finish.
- (vi) MCBDB's shall have removable type end plates with knockouts at the bottom and top, and shall have hinged covers with locking arrangement.
- (vii) Only the knobs of the MCBs shall protrude out of the front covers through openings neatly machine made for the purpose.
- (viii) The busbars used shall be solid electrolytic copper of appropriate sections.
- (ix) DIN bar(s) shall be provided for mounting the MCB's.

5.16 PREWIRED MCB DISTRIBUTION BAORDS

- (i) Prewired MCBDBs shall be provided only where specified.
- (ii) The complete boards shall be factory fabricated and shall be duly prewired in the works, ready for installation at site.
- (iii) The board shall be of wall mounted, cubical type construction, fabricated out of 1.6mm thick sheet steel, with stove enamelled paint finish.
- (iv) The board shall also be provided with a adopter box as a compartment for the complete width and, depth of the board, and of minimum height of 125mm in case of TPN DB's, and 100mm in case of SPN DB's.
- (v) (a) The board shall be provided with a hinged / removable type cover of 1.6mm thick sheet steel in the front.
 - (b) Only the knobs of the MCBs shall protrude out of the front covers through openings neatly machine made for the purpose.
- (vi) Knock out holes at the bottom, and detachable plate with knock out holes at the top of the board shall be provided.
- (vii) The board shall be complete with the following accessories:-
 - (a) Copper busbar (s).
 - (b) Neutral link.
 - (c) Common earth bar.
 - (d) DIN bar for mounting MCBs.
 - (e) Terminal connectors suitable for incoming and outgoing cables.
 - (f) Earthing stud (s).

- (viii) PVC insulated copper conductors / insulated solid copper links, and terminated on to extended type terminal connectors, suitable for connections to the sizes of the respective conductors.
- (ix) (a) All incoming and outgoing wiring to the prewired MCBDB's shall be terminated only in extended terminal connectors
 - (b) The terminal connectors therefore, be so provided as to facilitate easy cable connections and subsequent maintenance.
- (x) (a) A common copper earth bar shall be provided within the loose wire box / adopter box
 - (b) The common neutral bar as well as the terminal connectors shall, however, be provided within the main compartment just below the loose wire box/ adopter box.

5.17 MINIATURE CIRCUIT BREAKERS (MCB's)

- (i) 'L' or 'B' series MCB's shall be used only for normal 'lighting' circuits.
- (ii) 'G' or 'C' series MCB's shall be invariably used for motor loads, halogen lamp fittings, sodium / mercury discharge lamps and all 'power' circuits.
- (iii) Ratings (A as well as KA), number of poles, type as MCB or isolator, etc. shall be as specified in the tender documents.

5.18 SWITCH BOARDS – APPLICATION AND TYPES

- (i) All items of switchgear and distribution boards (DB's) shall be installed on switch boards. (See (ii) below)
- (ii) Where specified by the Engineer-in-charge, only MCBDB's may be permitted to be installed directly recessed in wall without a switch board. In such cases, the metal cladding of the DB shall be suitable for recess mounting.
- (iii) Switch boards shall be one of the following types, as specified.
 - (a) Hinged type.
 - (b) Fixed type.
 - (c) Enclosed cubicle type.

5.19 SWITCH BOARD LOCATIONS

5.19.1 General aspects

- (i) Switch boards shall as far as possible be located as per drawings.
- (ii) The boards should be accessible from common areas like corridors, lobby areas, etc.
- (iii) Switch boards shall be located only in dry situations and in well ventilated spaces. They shall not be placed in the vicinity of storage batteries and exposed to chemical fumes.
- (vi) Switch boards shall not be erected above gas stoves, or sinks or within 2.5m of any washing unit in the washing rooms of laundries, or in the bath rooms, toilets or kitchens.

5.19.2 Main switch boards

- (i) Main switch boards shall be situated as near as practicable to the termination of service line, and shall be easily accessible without the use of any external aid, to quickly disconnect the supply in case of emergencies.
- (ii) Main switch boards shall be installed in rooms or suitable enclosed space having provisions for locking arrangement so as to safeguard against operation by unauthorized personnel.

5.19.3 Distribution switch boards

- (i) The distribution boards shall be located as near as possible to the centre of the load they are intended to control. These boards shall be fixed on suitable stanchion or wall, and shall be accessible for maintenance of MCBs.
- (ii) Where two or more distribution boards feeding low pressure circuits are fed from a supply at medium voltage, these distribution boards shall be :-
 - (a) Fixed not less than 2m apart; or
 - (b) Arranged so that two cannot be opened at a time, namely, they are interlocked, and metal case is marked "Danger-400". or
 - (c) Installed in a room or enclosure accessible to only authorized persons.

5.20 SWITCH BOARD CONSTRUCTION

5.20.1 Cubicle type switch boards

Cubicle type switch boards shall conform to Section 4 of "General Specifications for Electrical works (Part-IV – Substation), 1982".

5.20.2 Common requirements for all types of switch boards

- (i)(a) Switch boards, if unavoidably fixed in places likely to be exposed to weather, to drip, or to dampness, their outer casing shall be weather proof, and shall be provided with glands or bushings or adopted to receive screwed conduits according to the manner in which the cables are run.
- (b) PVC and double flanged bushes shall be fitted in the holes of the switches for entry and exit of wires.
- ii. When it is unavoidable to install in a situation where inflammable or explosive dust, vapor or gas is likely to be present, the switch boards shall be totally enclosed, or made flameproof as may be necessitated by the particular circumstances.
- iii. The various live parts, unless they are effectively screened by substantial barriers of non hygroscopic, non-inflammable, insulating material, shall be so spaced that an arc cannot be maintained between such parts and with earth.
- iv. In every case in which switches and fuses are fitted on the same pole, these fuses shall be so arranged that the fuses are not alive when their respective switches are in the 'off' position.

- v. No fuses, other than fuses in instrument circuit, shall be fixed on the back of, or behind a switch board panel, or frame.
- vi. Equipments which are on the front of a switch board shall be so arranged that inadvertent personal contact with live parts (direct contact) is unlikely during the manipulation of switch gears, changing of fuses, or like operations.
- vii. The arrangement of the switch gear shall be such that they shall be readily accessible, and their connections to all instruments and apparatus shall be easily traceable.
- viii. (a) Interconnections of the various mountings on the boards shall be done using PVC insulated conductors, or solid strips with PVC taping / sleeving, of appropriate sizes.
(b) Terminations shall be air tight such that local heating is avoided.
- ix. No holes, other than the holes by means of which the panel is fixed, shall be drilled closer than 1cm from any edge of the panel.
- x. (a) All the metal work of switch boards (factory made panel) shall be painted prior to erection with one coat of anti-rust primer.
(b) After erection, they shall be painted with two coats of appropriate enamel, or aluminium paint as required, on all sides wherever accessible.
- xi. (a) All switch boards shall be provided with "Danger Notice Plate" conforming to relevant Indian Standards.
(c) If required in the tender specifications, a pilot lamp shall be fixed and connected through an independent single pole switch and fuse to the busbars of the board.

5.21 SWITCH BOARD INSTALLATION

- i. Unless and otherwise specified in the tender documents, a switch board shall not be installed so that its bottom is within 1.25m above the floor, unless the front of the switch board is completely enclosed by a door, or the switch board is located in a position to which only authorized persons have access.
- ii. (a) There shall be a clear space of 1m in front of the switch boards.
(b) The space behind the switch boards shall be either less than 20cm or more than 75cm.
(c) If there are any attachments or bare connections at the back of the switch board, Rule 51(c) of the Indian Electricity rules shall apply.
- iii. (a) Hinged type boards shall be securely fixed on wall by means of rag bolts.
(b) Fixed type boards shall be installed by suitably grouting the framework on the wall and / or floor as required.
(c) Cubicle type boards shall be installed by suitable foundation bolts grouted in the floor, or alternatively, over masonry cable trenches on necessary channel sections, duly grouted as required.
- iv. (a) Cubicle type switch boards shall be recessed in the wall if so specified in the tender documents.

- (b) The front shall then be fitted with hinge panel with locking arrangement, the outer surface of door being flush with the wall.
- (c) Ample room shall be provided for the wiring / cable connections at the side and at the front between the switchgear mountings and the door.
- v. (a) The connections between the switchgear mounting and the outgoing cable upto the wall shall be enclosed in a protection pipe.
(b) where it is required to terminate a number of conduits on a board, it may be convenient to provide a suitable MS adopter box for the purpose. Such boxes shall be provided with the prior approval of the engineer-in-charge and this will be paid for separately.
- vi. All wires to the boards shall be bushed at the entries to avoid damage to insulation.
- vii. No apparatus shall project beyond any edge of the panel. No fuse body shall be mounted within 2.5cm of any edge of the panel.
- viii. Busbars and interconnecting strips in fabricated boards shall be PVC taped or sleeved in Red, Yellow, and Blue for phases, and Black for neutral. The interconnecting cables shall also follow this colour coding.
- ix. All unused holes in the boards and in the mountings shall be plugged suitably to avoid entry of insects.

5.22 WIRING OF SWITCH BOARDS AND DISTRIBUTION BOARDS

- (i) All connections between pieces of apparatus, or between apparatus and terminals on a board shall be neatly arranged in a definite sequence, following the arrangement of the apparatus mounted thereon, avoiding unnecessary crossings.
- (ii) Cables shall be connected to terminals either by crimped or soldered lugs, unless the terminals are of such a form that they can be securely clamped without cutting away of cable strands.
- (iii) All bare conductors shall be rigidly fixed in such a manner that a clearance of atleast 3.2cm is maintained between conductors of opposite polarity or phase, and between the conductors and any material other than insulating material.
- (iii) In a hinged type board, the incoming and outgoing cables shall be neatly bunched and shall be fixed in such a way that the door shall be capable of swinging through an angle of not less than 90 degrees.

5.23 MARKING OF APPARATUS

(i) Marking of earthed neutral conductor

- (a) On the main switchgear, where the conductors include an earthed conductor of a two wire system, or an earthed neutral conductor of a multi-wire system,

or a conductor which is to be connected thereto, an indication of a permanent nature shall be provided to identify the earthed neutral conductor.

- (b) The neutral conductor shall be black in colour.
- (ii) The main earthing terminal in the main switch board shall be permanently marked as "SAFETY EARTH – DO NOT REMOVE".
- (iii) (a) Where a board has more than one switch gear, each such switchgear shall be marked to indicate which section of the installation it controls.
(b) The main switchgear shall be marked as such.
- (c) Where there is more than one main switch board in the building, each such switch board shall be marked to indicate which section of the installation and building it controls.
- (iv) All distribution boards shall be marked 'L' for lighting or 'P for power and 'E' for essential as the case may be.
- (vii) When a board is connected to a voltage higher than 250V, all the terminals or leads of the apparatus mounted on it shall be marked in the following colours to indicate the different poles or phases to which the apparatus or its different terminals may have been connected.

A.C.

- (a) Three phases – Red
Blue & Yellow
- (b) Neutral - Black
- (c) Earth – Green

D.C.

- Three wire system.
2 outer wires – Red & Blue
- Neutral – Black
- Earth -Green

- (viii) All marking required under this rule shall be clear and permanent.

5.24 ATTACHMENT OF FITTINGS AND ACCESSORIES

5.24.1 Conduit wiring system

- (i)(a) All accessories like switches, socket outlets, call bell pushes and regulators shall be fixed in flush pattern inside the switch / regulator boxes.
 - (b) Accessories like ceiling roses, brackets, batten holders, stiff pendants, etc. shall be fixed on metal outlet boxes.
 - (c) The fan regulators may also be fixed on metal outlet boxes, if so directed by the Engineer-in-charge.
- (ii) Aluminium alloy or cadmium plated iron screws shall be used to fix the accessories to their bases.
- (iii) The switch box / regulator box shall normally be mounted with their bottom 1.25m from floor level, unless otherwise directed by the Engineer-in-charge.

5.24.2 FIXING TO WALLS AND CEILING

- (i) PVC sleeves / dash fasteners should normally be used for fixing to walls or ceiling.

- (ii) An approved type of asbestos or fibre fixing plug (rawl or Phil plug) with correct size of tools shall be used for plugging of walls or ceiling and done in a workman like manner.

5.24.3 FANS, REGULATORS AND CLAMPS

- (i) Ceiling fans including their suspension shall conform to relevant Indian Standards.
- (ii)(a) All ceiling fans shall be wired to ceiling roses or to special connector boxes, and suspended from hooks or shackles, with insulators between hooks and suspension rods.
 - (b) There shall be no joint in the suspension rod.
- (iii)(a) For wooden or steel joists and beams, the suspension shall consist of MS flat of size not less than 40mm x 6mm, secured on the sides of the joists or beams by means of two coach screws of size not less than 5cm for each flat.
 - (b) Where there is space above the beam, a through-bolt of size not less than 1.5cm dia. shall be placed above the beam from which the flats are suspended.
 - (c) In the latter case, the flats shall be secured from movements by means of another bolt and nut at the bottom of the beam.
 - (d) A hook consisting of MS rod of size not less than 12mm dia shall be inserted between the MS flat through oval holes on their sides.
 - (e) Alternatively, the flats may be bent inwards to hold tightly between them by means of a bolt and nut, a hook of 'S' form.
- (iv) In the case of 'I' beams, flats shall be shaped suitably to catch the flanges and shall be held together by means of a long bolt and nut.
- (v) For concrete roofs, a 12mm dia. MS rod on the shape of 'U' with their vertical legs bent horizontally at the top at least 19cm on either side, and bound to the top reinforcement of the roof shall be used.
 - a. In buildings with concrete roofs having a low ceiling height, where the fan clamp mentioned under sub clause
- (v) above cannot be used, or wherever specified, recessed type fan clamp inside a metallic box, shall be used.
 - b. Canopies on top of suspension rod shall effectively hide the suspension.
 - c. The leading in wire shall be of nominal cross sectional area not less than 1.5 sq.mm and shall be protected from abrasion.
 - d. Unless otherwise specified, all ceiling fans shall be hung 2.75m above the floor.
 - e. (a) In the case of measurement of extra down rod for ceiling fan including wiring, the same shall be measured in units of 10cm.
 - (b) Any length less than 5cm shall be ignored.

5.24.4 Exhaust fans

- (i) Exhaust fans shall conform to relevant Indian standards.

- (ii)(a) Exhaust fans shall be erected at the places indicated by the Engineer-in-charge.
- (b) For fixing an exhaust fan, a circular hole shall be provided in the wall to suit the size of the frame, which shall be fixed by means of rag bolts embedded in the wall. The hole shall be neatly plastered to the original finish of the wall.
- (c) The exhaust fan shall be connected to the exhaust fan point, which shall be wired as near to the hole as possible, by means of a flexible cord, care being taken to see that the blades rotate in the proper direction.
- (iii) Exhaust fans for installation in corrosive atmosphere, shall be painted with special PVC paint or chlorinated rubber paint.

5.24.5 Regulators

The metallic body of regulators of ceiling fans / exhaust fans shall be connected to earth by protective conductor.

VI) SPECIFICATION FOR METALLIC CONDUIT WIRING SYTEM

6.1.0 SCOPE

The detailed requirements for wiring work in metallic conduits for both surface and recessed types of works.

6.1.1 Application

- (a) Recessed conduit is suitable generally for all applications.
- (b) Surface conduit work may be adopted in places like workshops, plant rooms, pump rooms, wiring above false ceiling / below false flooring, and at locations, where recessed work may not be possible to be done.
- (c) The type of work, viz. surface or recessed shall be as specified in the respective schedule of works.
- (d) Flexible conduits may only be permitted for interconnections between switchgear, DB's and conduit terminations in wall.
- (e) All rigid conduit pipes shall be of steel and ISI marked.
- (f) The wall thickness shall be not less than 1.6mm for conduits upto 32mm dia. and not less than 2mm for conduits above 32mm dia.
- (g) The steel conduit pipes shall be solid drawn or reamed by welding, and finished with galvanized or stove enameled surface.
- (h) The maximum number of PVC is insulated wires conforming to IS:694-1490 that can be drawn in one conduits given size-wise in Table I, and the number of wires per conduit shall not be exceeded..
- (i) Conduit sizes shall be selected accordingly in each run.
- (j) No steel conduit less than 20mm in diameter shall be used.

6.1.2. Materials

6.1.2.1 Conduits

6.1.2.2 Conduit accessories

- (i) The conduit wiring system shall be complete in all respects, including their accessories.
- (ii) All conduit accessories shall be of threaded type, and under no circumstances pin grip type or clamp grip type accessories shall be used.
- (iii) Bends, couplers etc. shall be solid type in recessed type of works and may be solid or inspection type as required, in surface type of works.
- (iv)(a) Saddles for surface conduit work on wall shall not be less than 0.55mm for conduits upto 25mm dia and not less than 0.9mm for larger diameter. The corresponding width shall be 19mm & 25mm.
- (b) The minimum width and the thickness of girder clips used for fixing conduits to steel joists, and clamps shall be as per Table II.

6.1.2.3 Outlet boxes

- i. Modular boxes of same make as of modular switch/socket are to be used.
- ii. Where a large number of control switches and / or fan regulators are required to be installed at one place, these shall be installed in more than one outlet box adjacent to each other for ease of maintenance.
- iii. An earth terminal with stud and 2 metal washers shall be provided in each MS box for termination of protective conductors and for connection to socket earth terminal / metallic body of fan regulator etc.
- iv. The fan regulators can also be mounted on the switch box covers, if so stipulated in the tender specifications, or if so directed by the Engineer-in-Charge.

6.1.3 INSTALLATION

6.1.3.1 Common aspects for recessed and surface conduit works.

(i) Conduit joints.

- (a) The conduit work of each circuit or section shall be completed before the cables are drawn in.
- (b) Conduit pipes shall be jointed by means of screwed couplers and screwed accessories only.
- (c) Cut ends of conduit pipes shall have no sharp edges, nor any burrs left to avoid damage to the insulation of the conductors while pulling them through such pipes.
- (d) No bare threaded portion of conduit pipe shall be allowed, unless such bare threaded portion is treated with anticorrosive preservative or covered with approved plastic compound.

(ii) Bends in conduit

- (a) All necessary bends in the system, including diversion, shall be done either by neatly bending the pipes without cracking with a bending radius of not less than 7.5cm, or alternatively, by inserting suitable solid or inspection type normal bends, elbows or similar fittings, or by fixing cast iron inspection boxes, whichever is most suitable.
- (b) No length of conduit shall have more than the equivalent of four quarter bends from outlet to outlet.
- (c) Conduit fittings shall be avoided as far as possible on conduit system exposed to weather. Where necessary, solid type fittings shall be used.
- (iii) Outlets**
 - (a) All outlets such as switches, wall sockets etc. may be either flush mounting type, or of surface mounting type.
 - (b) All switches (except piano type switches), socket outlets and fan regulators shall be fixed on metal strips which shall be screwed / welded to the box. Piano type switches and accessories shall be fixed on the phenolic laminated sheet covers in flush pattern.
- (iv) Painting after erection**

Accessible outer surface conduit pipes to be painted.

6.1.3.2 Additional requirements for surface conduit work.

- (i) Painting before erection**

The outer surface of conduit including all bends, unions, tees, junction boxes, etc. forming part of the conduit system, shall be adequately protected against rust by being painted with 2 coats of red oxide paint applied before they are fixed.
- (ii) Fixing conduit on surface**
 - a. Conduit pipes shall be fixed by saddles, secured to suitable approved plugs with screws in an approved manner at an interval of not more than one metre, but on either side of the couplers or bends or similar fittings, saddles shall be fixed at a distance of 30cm from the centre of such fittings.
 - b. Where conduit pipes are to be laid along the trusses, steel joists etc. the same shall be secured by means of saddles or girder clips or clamps as required by the Engineer-in-charge.
 - c. In long distance straight run of conduit, inspection type couplers at reasonable intervals shall be provided.
- (iii) Fixing outlet boxes**

Only a portion of the switch box shall be sunk in the wall, the other portion being projected out for suitable entry of conduit pipes into the box.

6.1.3.3 Additional requirements for recessed conduit work

(i) **Making chase**

- a. The chase in the wall shall be neatly made, and of ample dimensions to permit the conduit to be fixed in the manner desired.
- b. In the case of buildings under construction, the conduits shall be buried in the wall before plastering, and shall be finished neatly after erection of conduit.
- c. In case of exposed brick / rubble masonry work, special care shall be taken to fix the conduit and accessories in position along with the building work.

(ii) **Fixing conduits in chase**

- (a) The conduit pipe shall be fixed by means of staples, J-hooks, or by means of saddles, not more than 60cm apart, or by any other approved means of fixing.
- (b) All threaded joints of conduit pipes shall be treated with some approved preservative compound to secure protection against rust.

(iii) **Fixing conduits in RCC work**

- (a) The conduit pipes shall be laid in position and fixed to the steel reinforcement bars by steel Binding wires before the concreting is done.
- (b) The conduit pipes shall be fixed firmly to the steel reinforcement bars to avoid their dislocation during pouring of cement concrete and subsequent tampering of the same.
- (c) Fixing of standard bends or elbows shall be avoided as far as practicable, and all curves shall be maintained by bending the conduit pipe itself with a long radius which will permit easy drawing in of conductors.
- (d) Location of inspection / junction boxes in RCC work should be identified by suitable means to avoid unnecessary chipping of the RCC slab subsequently to locate these boxes.

(iv) **Fixing inspection boxes**

- (a) Suitable inspection boxes to the minimum requirement shall be provided to permit inspection, and to facilitate replacement of wires, if necessary.
- (b) These shall be mounted flush with the wall or ceiling concrete. Minimum 65mm depth junction boxes shall be used in roof slabs.
- (c) Suitable ventilating holes shall be provided in the inspection box covers.

(v) **Fixing switch boxes and accessories**

- a. Switch boxes shall be mounted flush with the wall.
- b. All outlets such as switches, socket outlets etc. shall be flush mounting type.

(vi) **Fish wire**

To facilitate subsequent drawing of wires in the conduit, GI fish wire of 1.6mm / 1.2mm shall be provided along with the laying of the recessed conduit.

(vii) **Bunching of cables**

- a. Cables carrying direct current may, if desired, be bunched whatever their polarity, but cables carrying alternating current if installed in metal conduit shall always be bunched so that the outgoing and return cables are drawn into the same conduit.
- b. Where the distribution is for single phase loads only, conductors for these phases shall be drawn in one conduit.
- c. In case of three phase loads, separate conduits shall be run from the distribution boards to the load points, or outlets as the case may be.

6.1.3.4 Earthing requirements

- (i)
 - a. The entire system of metallic conduit work, including the outlet boxes and other metallic accessories, shall be mechanically and electrically continuous by proper screwed joints, or by double check nuts at terminations.
 - b. The conduit shall be continuous when passing through walls or floors.
- (ii)
 - a. Protective (loop earthing) conductor(s) shall be laid along the runs of the conduit between the metallic switch boxes and the distribution boards / switch boards, terminated there to the conductors shall be of such size and material as specified.
 - b. Depending upon their size and material, the protective earth conductors shall be either drawn inside the conduits along with the cables, or shall be laid external to the conduits at regular intervals.
- iii. The protective conductors shall be terminated properly using earth studs, earth terminal block etc. as the case may be.
- iv. Gas or water pipe shall not be used as protective conductor (earth medium).

SECTION - VII

TABLE- I

Maximum number of PVC insulated 650 / 1100V grade aluminium / copper conductor cable conforming to IS:694-1990

Nominal cross-sectional area of conductor in Sq.mm.	20mm		25mm		32mm		38mm		51mm		64mm	
	S	B	S	B	S	B	S	B	S	B	S	B
1	2	3	4	5	6	7	8	9	10	11	12	13
<u>1.50</u>	<u>5</u>	<u>4</u>	<u>10</u>	<u>8</u>	<u>18</u>	<u>12</u>	--	--	--	--	--	--
<u>2.50</u>	<u>5</u>	<u>3</u>	<u>8</u>	<u>6</u>	<u>12</u>	<u>10</u>	--	--	--	--	--	--
<u>4</u>	<u>3</u>	<u>2</u>	<u>6</u>	<u>5</u>	<u>10</u>	<u>8</u>	--	--	--	--	--	--
<u>6</u>	<u>2</u>	--	<u>5</u>	<u>4</u>	<u>8</u>	<u>7</u>	--	--	--	--	--	--
<u>10</u>	<u>2</u>	--	<u>4</u>	<u>3</u>	<u>6</u>	<u>5</u>	<u>8</u>	<u>6</u>	--	--	--	--
<u>16</u>	--	--	<u>2</u>	<u>2</u>	<u>3</u>	<u>3</u>	<u>6</u>	<u>5</u>	<u>10</u>	<u>7</u>	<u>12</u>	<u>8</u>
<u>25</u>	--	--	--	--	<u>3</u>	<u>2</u>	<u>5</u>	<u>3</u>	<u>8</u>	<u>6</u>	<u>9</u>	<u>7</u>
<u>35</u>	--	--	--	--	--	--	<u>3</u>	<u>2</u>	<u>6</u>	<u>5</u>	<u>8</u>	<u>6</u>
<u>50</u>	--	--	--	--	--	--	--	--	<u>5</u>	<u>3</u>	<u>6</u>	<u>5</u>
<u>70</u>	--	--	--	--	--	--	--	--	<u>4</u>	<u>3</u>	<u>5</u>	<u>4</u>

Note:

- 1) The above table shows the maximum capacity of conduits for a simultaneous drawing in of cables.
- 2) The columns headed 'S' apply to runs of conduits which have distance not exceeding 4.25m between draw in boxes and which do not deflect from the straight by an angle of more than 15 degrees. The columns headed 'B' apply to runs or conduit which deflect from the straight by an angle of more than 15 degrees.
- 3) Conduit sizes are the nominal external diameters.

TABLE-II

Girder clips or clamps

Size of conduit	Width	Thickness
(i) 20mm	19mm	0.9mm (20 SWG)
(ii) 25mm	19mm	0.9mm (20 SWG)
(iii) 32mm & above	25mm	1.2mm (18 SWG)

1. While the Indian Electricity Rules 1956, as amended upto date, are to be followed in their entirety. Any installation or portion of installation which does not comply with these rules should be got rectified immediately.
2. The detailed instructions on safety procedures given in B.I.S. Code No. 5216-1969- II Code of Safety Procedures and Practices in Electrical Works" shall be strictly followed.
3. It shall be the responsibility of the Junior Engineer (E) and the Assistant Engineer (E) to see that the control switches and distribution boards are duly marked, the distribution diagrams of sub-stations are prominently displayed, and the sub-station premises, main switch rooms and D.B. enclosure are kept clean. particular care should be taken to prevent the sub-station being used as store for inflammable materials, broken furniture, waste materials etc.
4. No inflammable materials shall be stored in places other than the rooms specially constructed for this purpose in accordance with the provisions of Indian Explosives Act. If such storage is unavoidable, it should be allowed only for a short period and in addition, special precautions, such as cutting off the supply to such places at normal times, storing materials away from wiring and switch boards, giving electric supply for a temporary period with the permission of Junior Engineer (E) shall be taken.
5. Rubber or insulating mats should be provided in front of the main switch boards or any other control equipments of medium voltage and above.
6. Protective and safety equipments such as rubber gauntlets or gloves, earthing rods, line men's belt, portable artificial respiration apparatus etc. should be provided in each sub-station, service centre/ enquiry office and important installations. Where electric welding or such other nature of work is undertaken, goggles shall also be provided.
7. Necessary number of caution boards such as "Man on Line, Don't switch on" should be readily available in each sub-station, enquiry office and important installations.
8. Standard first aid boxes containing materials as prescribed by the St. John Ambulance Brigade or Indian Red Cross should be provided in each sub-station, enquiry office and important installations and should be readily available.
9. Periodical examination of the first aid facilities and protective and safety equipments provided at the various installations shall be undertaken for their adequacy and effectiveness and a proper record shall be maintained.
10. Charts (one in English and another one in the regional language) displaying methods of giving artificial respiration to a recipient of electrical shock should be prominently displayed at appropriate places.
11. A chart containing the names, addresses and telephone numbers of nearest authorised medical practitioners, hospitals, Fire Brigade and also of the officers in executive charge shall be displayed prominently alongwith the First

Aid Box.

12. Secretaries should take immediate steps to train supervisory and authorised persons of the Engineering staff viz. A.Es., J.Es, Head Electricians, Foremen, Electricians and wiremen in the First Aid Practices, including various methods of artificial respiration with the help of local authorities such as Fire Brigade, St. John Ambulance Brigade, Indian Red Cross or other recognised institutions equipped to impart such training, as prompt rendering of artificial respiration can save life at times of electric shock.
13. All new recruits should be given such First Aid Training immediately after appointment.
14. All Supervisory and authorized persons of the Engineering staff should be deputed for refresher course in First Aid Training after every two years.
15. Details of preventive maintenance to be undertaken shall be in accordance with the schedule given at serial number 28 of this appendix. All preventive maintenance works shall be pre-planned as far as possible and names of persons who are assigned to this work should be entered in a log book.
16. Electrical wiring and control switches should be periodically inspected and any defective wiring, broken parts of switches which will expose live parts, should be replaced immediately to make the installations safe for the user.
17. Reports indicating details of preventive maintenance works done should be kept in a register by each JTO (E) and should bear signatures of SDE and SECRETARY JIADA by way of checks.
18. No work shall be undertaken on live installations, or on installations which could be energized unless one another person is present to immediately isolate the electric supply in case of any accident and to render first aid, if necessary.
19. No work of live L.T. busbar or pedestal switch board in the sub-stations should be handled by a person below the rank of a Wireman and such a work should preferably be done in the presence of the Junior Engineer (E) in charge of the work.
20. When working on or near live installations, suitably insulated tools should be used, and special care should be taken to see that those tools accidentally do not drop on live terminals causing shock or dead short.
21. The electrical switchgears and distribution boards should be clearly marked to indicate the areas being controlled by them.
22. Before starting any work on the existing installation, it should be ensured that the electric supply to that portion in which the work is undertaken is preferably cut off. Precautions like displaying Live Men at Work caution boards on the controlling switches, removing fuse carrier from these switches, and these fuse carriers being kept with the person working on the installation, etc. should be taken against accidental energisation. I permit to Work II should be obtained from the Junior Engineer-in-Charge. No work on H.T. main should be undertaken unless it is made dead and discharged to earth with an earthing lead of appropriate size. The discharge operation shall be repeated several

times and the installation connected to earth positively before any work is started.

23. Before energizing on an installation after the work is completed, it should be ensured that all tools have been removed and accounted, no person is present inside any enclosure of the switch board etc. any earthing connection made for doing the work has been removed, "Permit to Work" is received back duly signed by the person to whom it was issued in token of having completed the work and the installation being ready for reenergizing and "Men at Work" caution boards removed.
24. In case of electrical accidents and shock, the electrical installation on which the accident occurred should be switched off immediately and the affected person should be immediately removed from the live installation by pulling him with the help of his coat, shirt, wooden rod, broom handle or with any other dry cloth or paper. He should be removed from the place of accident to a nearby safe place and artificial respiration continuously given as contained in B.I.S. Code and Standard prescribed by St. John Ambulance Brigade or Fire Brigade.
25. While artificial respiration on the affected person is started immediately, help of Fire Brigade and Medical practitioner should be called for and artificial respiration should be continued uninterrupted until such help arrives.
26. These instructions should be explained in Hindi/ local language to those staff who do not "understand English.

IX ANNEXURE -B

FORM OF COMPLETION CERTIFICATE

I/We certify that the installation detailed below has been installed by me/us and tested and that to the best of my/our knowledge and belief it complies with Indian Electricity Rules, 1956, as well as the C.P.W.D. General specifications of Electrical Works 1994.

Electrical installation at _____

Voltage and system of supply _____

I. Particulars of work:

a) Internal Electrical Installation No. Total load: Type or system of wiring

(i) Light point

(ii) Fan point

(iii) Plug Point

a) 3 pin 5 amp

b) 3 pin 15 Amp

b) Others Description HP/KW Type of Starting

(a) Motors: (i)

(ii)

(iii)

c) Other plants:

d) If the work involves installation of over head line and/or underground cable

a. (i) Type & description of overhead line.

(ii) Total length and no of spans.

(iii) No. of Street Lights and its descriptions.

b. (i) Total length of underground cable & its size.

(ii) No. of joints: End joint:

Tee joint:

St. through joint:

II. Earthing

(i) Description of earthing electrode.

(ii) No. of earth electrodes.

(iii) Size of main earth lead.

III. Test results:

a. Insulation resistance

i. Insulation resistance of the whole system of conductors to earth
..... Megaohms.

ii. Insulation between the phase conductor and neutral.

Between Phase R and neutral - - Mega-ohms

Between Phase Y and neutral - - Mega-ohms

Between Phase B and neutral - - Mega-ohms

iii. Insulation resistance between the phase conductors in case of

Polyphase supply.

Between Phase R and neutral	-	-	Mega-ohms
Between Phase Y and neutral	-	-	Mega-ohms
Between Phase B and neutral	-	-	Mega-ohms

b. Polarity test

Polarity of non linked single pole branch switches.

c. Earth continuity test

Maximum resistance between any point in the earth continuity conductor including metal conduits and main earthing lead Ohms.

d. Earth electrode resistance

Resistance of each earth electrode

- (i) Ohms.
- (ii) Ohms.
- (iii) Ohms.
- (iv) Ohms.

e. Lightning protective system

Resistance of the whole of lightning protective system to earth before any bonding is effected with earth electrode and metal /on the structure Ohms.

Signature and name of JTO (E)/ SDE(E) Signature and Name of the Contractor

X) TECHNICAL SPECIFICATION FOR EARTHING

10.1.1 EARTHING

10.1.1.1 SCOPE

This specification covers the supply, installation testing and commissioning of Earthing system.

10.1.2 GENERAL REQUIREMENTS

The plant shall be provided with complete earthing system comprising earth electrodes in conjunction with earth grid.

10.1.3 DETAILS OF EARTHING SYSTEM

- i. Unless otherwise specified main earthing shall not be less than 25x5mm Cu. flat.
- ii. The minimum size of earthing conductor of various equipment shall be as follows:
 - a. Main Earth Bus - 50 x 12.5 mm Cu Flat
 - b. LT Switch boards body - 25 x 5 mm Cu Flat
 - c. Distribution Panels - 25 x 5 mm Cu Flat
 - d. Interconnections Earth pit to Earth pit - 25 X 5 mm Cu. Flat

10.1.4 EARTH ELECTRODE

Earth electrodes shall be erected 1.5 Mts away from the building edge and minimum spacing of 3 mtrs between the electrodes shall be maintained as per IS: 3043

10.1.5 EARTHING LAYOUT

- a. Earthing conductors in outdoor areas shall be buried at least 600mm below finished ground level unless stated otherwise.
- b. Wherever earthing conductors cross cable trenches, underground service ducts, pipes, tunnels, etc. it shall be laid minimum 300 mm below and shall be re-routed in case it fouls with equipment structure foundations.
- c. Tap-connections from the earthing grid to the equipment/structure to be earthed shall be terminated on earthing terminals of the equipment/structure, if the equipment is available at the time of laying the grid, otherwise, "earth riser" shall be provided near the equipment foundation/ pedestal for future connections to the equipment earthing terminals.
- d. (i) Earthing conductors along their run on cable trench ladder columns, beams, walls, etc. Shall be supported by suitable cleating at intervals of 750 mm.
(ii) Earthing conductors along cable trenches shall be cleared to the wall nearer to the equipment.
(iii) Cable trays and supports shall be connected to the earth mat at every 10 meters interval.

(iv) Wherever it passes through walls, floors, etc. GI sleeves shall be provided for the passage of the conductor.

10.1.6 EQUIPMENT EARTHING

- a. All electrical power items shall be earthed by two separate and distinct earth connections from main earth bus.
- b. Earthing pads shall be provided by the supplier of the apparatus/equipment at accessible position.
- c. The connection between earthing pads and the earthing grid shall be made by short and direct earthing lead free from kinks and splices.
- d. Electrical continuity shall be ensured by bonding the different sections of hand-rails and metallic stairs.
- e. Metallic pipes, and cable tray sections for cable installation shall be bonded to ensure electrical continuity and connected to earthing conductors at regular interval. Apart from intermediate connections, beginning points shall also be connected to earthing system.
- f. Metallic conduits shall not be used as earth continuity conductor.
- g. Wherever earthing conductor crosses or runs along metallic structures such as gas, water, steam, conduits, pipes etc. and steel reinforcement in concrete, it shall be bonded to the same.
- h. Cable end boxes, glands, etc. shall be connected to the earthing conductor running along with the supply cable which, in turn, shall be connected to earthing grid conductor at minimum two points.

10.1.7 JOINTING

- a. Earthing connections with equipment earthing pads shall be bolted type. Contact surface shall be free from scale, paint enamel, grease, rust or dirt.
- b. Two bolts shall be provided for making each connections. Bolted connections, after being checked and tested shall be taped with PVC tape.
- c. Resistance of the joint shall not be more than the resistance of the equivalent length of the conductor.

10.1.8 GENERAL

- a. Excavation and refilling of earth necessary for laying of under ground earth bus and earth pipes shall be the responsibility of the Contractor.
- b. All earth electrodes shall be tested for earth resistance by means of standard earth resistance tester.
- c. Earthing resistance of the main bus shall be measured after connecting all the electrodes to the bus and the resistance shall not exceed 2(Two) ohm.
- d. The exact location of Earth Bus/conductor, earth electrodes and earthing points on the equipment shall be determined at site in

consultation with Engineer-in-charge. Any change of methods, routing, size of conductor shall be subject to approval by Engineer-in-charge.

XI) TECHNICAL SPECIFICATION FOR TESTING AND COMMISSIONING

11.1.0 PREPARATION OF THE ELECTRICAL SYSTEM FOR COMMISSIONING

- a. Checking required to be made on all equipment and installations at site shall comprise, but not be limited, to the following:

The following checks shall be made on all equipment and installations at site:

- I. Physical inspection for removal of any foreign bodies, external defects, such as damaged insulators, loose connecting bolts, loose foundation bolts etc.
- ii. Check for grease, insulating/lubricating oil leakage and its proper quantity.
- iii. Check for the free movement of mechanism for the circuit breakers, rotating part of the rotating machines and devices.
- iv. Check for tightness of all-cable, busbars at termination/ joints ends as well as earth connections in the main earthing network.
- v. Check for clearance of live busbars and connectors from the metal enclosure.
- vi. Check for proper alignment of all draw out device like draw out type circuit-breakers.
- vii. Continuity check in case of power cables.
- viii. Checking of all mechanical and electrical interlocks including tripping of breakers using manual operation of relay.
- ix. Checking of alarm and annunciation circuits by manual actuation of relevant relays.
- x. Check and calibrate devices requiring field adjustment/ calibration like adjustment of relay settings etc.
- xi. Check proper connection to earth network of all noncurrent carrying parts of the equipment and installation.
- xii. Test reports for all meters are to be furnished.
The tests that shall be carried out on the equipment shall include but not be limited to the above.

11.1.1 Low Voltage Switchgear (upto 1000V AC or 1200V DC)

- I. Insulation resistance test with 1000V megger for main circuits. The minimum value of insulation resistance shall be 1 megohm.
- ii. Insulation resistance test with 500V megger for control, metering and relaying circuits. The minimum value of insulation resistance shall be one megohm.
- iii. Relay operation test by primary & secondary injection method.
- iv. Functional tests of control circuit.
- v. Checking of settings of all relay/releases as per single line diagram/specification.
- vi. ON/OFF operation of breakers both manually and electrically in "Test" as well as "Service" positions.

11.1.2 Cables

- I. Insulation resistance test with 2,500 V megger for high voltage power cables rated above 1.1 KV grade and 1,000 V megger for cables rated up to 1.1 KV grade.
- ii. All cables of 1.1 KV and all H.V. cables shall be subjected to high voltage test after joining and terminating but before commissioning as per relevant standards.
- iii. In each test, the metallic sheath/screen/armor should be connected to earth.
- v. Continuity of all the cores, correctness of all connections as per wiring diagram, correctness of polarity and phasing of power cables and proper earth connection of cable glands, cable boxes, armor and metallic sheath, shall be checked.

11.1.3 Earthing System

- i. Tests to ensure continuity of all earth connections.**
- ii. Tests to obtain earth resistance of the complete network by using earth tester. The test values obtained shall be within the limits.
- iii. All documents / records regarding test data and other measured values of important parameters finalised after site adjustment shall be handed over to the Engineer-in-charge in the form of test reports for their future use and reference.

11.1.4 Form of completion certificate:

- i. Before commissioning all the equipments the routine tests are to be conducted at site in presence of Engineer-in-charge or his authorised representative.
- ii. Completion certificate shall be submitted as per Annexure – B.

SPECIAL CODITIONS OF CONTRACT FOR EI & FANS

1. General

The special conditions shall be read in conjunction with general conditions of contract and amendments / corrections thereto, Additional Conditions (General) and Additional Conditions (Electro-Mechanical). If there are any provisions in these special conditions, which are at variance with the provision in the above-mentioned documents, the provisions in these special conditions shall take precedence.

2. DRAWINGS TO BE SUBMITTED FOR APPROVAL:

The firm shall supply the following shop drawings within 30 days after award of the work as detailed below.

- ❖ Drawings showing the position of fittings, including Emergency fittings, switch boards and plug points etc.
- ❖ Detail drawings showing location of DBs with phase balancing details.
- ❖ Schematic diagram showing all connections in the complete electrical system.
- ❖ Location drawings of rising main, cable trays, raceways layouts and junction box with necessary catalogues.
- ❖ Drawings showing the position of Advance Lightning conductor Air terminal, Down conductor, Spike counter and Earth pits.
- ❖ Drawing showing the location of Signage lighting Fire Escape route lighting including common control at Ground floor

3. INSPECTION:

The **JIADA** reserves the right to carry out inspection and testing at manufacturer's works for any equipment/item prescribed in this contract. Samples of materials like accessories, switches, conduit, wire etc shall be submitted to the **JIADA** for approval.

4. TESTING AT SITE:

Following tests shall be carried out at site as per JSOR specifications and report submitted to the Engineer-in-charge.

The installed system shall be tested by the **JIADA** Committee / Acceptance Testing before commissioning as per Form of Completion certificate enclosed in the technical specification of EI and Fans.

5. COMPLETION OF WORK:

- a) Date of completion of work for the Electrical Installation (Internal Electrical Installation) shall be the last date of successful testing and commissioning of the installations by the **JIADA** Committee / Acceptance Testing.
- b) The above date shall be the date of completion of Work only for the purpose of settlement of bills / payments. However the guarantee period shall start from the date of completion of overall project. The operation and maintenance along with providing man power and materials upto date of taking over (date of completion of overall project) by JIADA shall be the responsibility of Principal Contractor as provided in the Additional conditions (Electro Mechanical). Nothing extra shall be paid on this account. The Security Deposit shall be released after the successful completion of guarantee period.

6. COMPLETION DRAWINGS:

The firm shall supply five sets of drawings/documents after completion of the work as detailed below:

- ❖ Drawings showing the position of fitting, including Emergency fittings switch boards and plug points etc.
- ❖ Detail drawings showing location of DBs with phase balancing details.
- ❖ Schematic diagram showing all connections in the complete electrical system.
- ❖ Location drawings of rising main, cable trays, raceways layouts and junction box.
- ❖ Drawings showing the position of Advance Lightning conductor air terminal, Down conductor, Spike counter and Earth pits.
- ❖ Drawing showing the location of Signage lighting Fire Escape route lighting including common control at Ground floor

CONTRACTOR**ENGINEER IN CHARGE****LIST OF APPROVED MAKES FOR ELECTRICAL ITEMS**

S. No.	Items	Makes
1	Engine	Ashok Leyland /Cummins/ Cater pillar / KOEL/ Volvo Penta / Mahindra & Mahindra (up to 40 KVA) /Escorts (up to 30 KVA)/ Eicher (up to 20 KVA)
2	Alternator(Brushless)	Crompton Greaves (AL. series) / KEC / Leroy Somer / Stamford / Jyoti Ltd
3	Battery (Lead Acid / Mntc. Free)	Amara Raja / AMCO / Farukawa / Hitachi / Exide/ Prestolite / Standard
4	HV Switchgear (Vacuum Circuit Breaker/SF6)	Biecco Lawrie / Crompton / Kirloskar / MEI / Jyoti Ltd
5	Transformer (Oil filled / Dry type)	ABB / Schneider Electric /Andrew Yule / Bharat Bijlee / Crompton / EMCO / Kirloskar / Siemens
	a) Above 400 KVA	
	b) Up to 400 KVA	In addition to above makes, Uttam/Automatic Electric Gear(AEG)/Patson/Rajasthan Transformer and Switchgear
6	Air Circuit Breaker	L&T/ Schneider Electric / Siemens
7	MCCB(Ics=Icu)	L&T/ Schneider Electric / Siemens
8	SDF units	L&T/ Schneider Electric / Siemens / HPL/Havells
9	Power Contactors	L&T/ Schneider Electric / Siemens/ Lakshmi(LECS)
10	Change Over Switch	HPL / Havells / H-H Elcon
11	Intelligent APFC Relay	L&T/EPCOS(Siemens) / Schneider Electric / Neptune Ducati/Syntron/ABB
12	Bus Bar Trunking / Sandwiched Bus Duct	Moeller/L&T/Schneider Electric/ABB/Legrand/Zeta
13	Power Capacitors (MPP/APP)	L&T / EPCOS(Siemens) / ABB / Crompton / Schneider Electric / Neptune Ducati
14	Digital/ KWHr meter	Schneider Electric / AE / Digitron / IMP / Meco / Rishabh / Universal / HPL / L&T / ABB
15	Cold shrink HT/LT Cable Joint	Denson / 3M(M-Seal)/ Raychem
16	Rubber Matting	ISI mark
17	MCB/ Isolator / ELCB / RCCB / Distribution Board	Crompton / Havells / Indokopp / MDS Legrand/ L&T / Schneider Electric/ Siemens / Standard/ C&S/ABB/HPL
18	MS/ PVC Conduit	ISI mark
19	Cable Tray	MEM/Bharti/Ratan/Slotco/Profab
20	HT/LT Cables	ISI mark
21	PVC insulated copper conductor wire	ISI mark
22	Centrifugal Pump	Amrut / BE / Beacon / Batliboi / Crompton / Jyoti / Kirloskar / KSB / Mather & platt / WASP/Grundfos
23	Submersible Pump	Crompton/Amrut / BE / Calama / Kirloskar / KSB
24	Motors	ABB / Bharat Bijlee / Crompton Greaves / Schneider Electric / HBB / KEC / Siemens/ Jyoti Ltd

25	Fresh Air Fans	GE / Khaitan / Almonard / Crompton
26	Starter	ABB / BCH / Schneider Electric / L&T / Siemens /
27	Single Phase Preventer	L&T / Minilec / Siemens / Zerotrip
28	GI/MS Pipe	ATC / ATL / BST / GSI / ITC / ITS / IIA / JST / Jindal / TTA / Tata / Zenith
29	Foot Valve	ISI mark
30	Gate Valve	Advance / Audco / Johnson Controls / Zoloto / Annapurna / Fountain / Kirloskar / Leader / Sant / Trishul
31	Compressors	Carrier / Emerson Copeland / York / Danfoss (for chillers only)
32	Resin Bonded Glass wool	Fibre Glass / Pilkington / UP Twiga
33	Expanded Polystyrene	BASF(India) Ltd.
34	Gauge	Feibig / H.Guru / Pricol
35	Controls	FLICA / Honeywell / Indfoss / Penn- Danfoss / Ranco / Ranutrol / Sporland
36	Fine Filters	Anfiltra Effluent / ARW / Athlete/ Airtake/ Dyna / Kirsloskar/ Puromatic / Purafill / Purolator / Tenacity
37	GI Sheet	HSU Jindal / National / Nippon Denro / Sail / Tata
38	Heat Detector	Appollo / Chemtron/ Edward / Fenwal/ Hochiki / Nitton /System Sensor/ Wormald /Honeywell Essar /Notifier
39	Ionization Detector	Appollo / Cerebrus / Edward / Fenwal / Hochiki / Nitton / System Sensor / Wormald
40	Photo Electric Smoke Detector	Appollo / Cerebrus / Edward / Fenwal/ Hochiki / Nitton / Wormald
41	Fire Panel (Microprocessor based)	Agni Instruments / Agni Devices / Aruna Agencies/ Carmel Sensor / Ravel Elect./ Honeywell Essar / Notifier / Navin Systems
42	Sprinkler/ Hose Reel & Hose Pipe	ISI mark
43	Fire Extinguisher	ISI mark
44	Lift	OTIS, Kone, Mitsubishi , Schindler, Johnson

It is certified that I have gone through the above list of preferred make of materials and the rates has been quoted accordingly.

(Signature of Contractor)

RELEVANT CODES TO BE FOLLOWED

Following codes are to be followed in connection with design and execution of the work.
(If the code is amended, the amended version of code will be followed) Sl. No.

Sr. No.	IS No.	Description
1	General IS – 1200 (Part 1 to 28)	Measurement of building works, method, materials & details of construction.
2	Cement IS – 269:1989	Ordinary, Rapid hardening & low heat Portland cement – 33grade
3	IS – 8112:1989	Ordinary, Rapid hardening & low heat Portland cement – 43 grade
4	IS – 12269:1987	Ordinary, Rapid hardening & low heat Portland cement – 53 grade
5	IS – 1489 (Part 1 & 2): 1991	Portland Pozzloan Cement
6	Sand IS – 1542	Sand for plaster
7	IS:2116 – 1980	Sand for masonry mortars.
8	Aggregates IS: 383 – 1970	Aggregates coarse and fine from natural sources for concrete.
9	Aggregates IS:515 – 1959	Aggregates for use in Mass Concrete Neutral and manufactured.
10	Bricks IS: 1077 – 1992	Common Burnt clay building bricks
11	IS: 2211 – 1991	Code of practice for brick work
12	Soil IS : 1489 – 1970	Classification & identification of soil for General Engineering purpose
13	Concrete IS:456:1978	Code of practice for plain & reinforced concrete (third version) with amendment no 2
14	IS : 455 – 1989	Portland slag cement
15	IS: 2250-1981	Preparation and use of masonry mortar
16	IS: 6452 – 1989	High Alumina cement for structural us
17	IS: 8041 – 1990	Rapid hardening Portland cement
18	IS – 3370	Part I/1965 – Code of Practice for concrete structures for the storage of Liquids- General requirements.
19	IS : 3370	Part II/1965 – do- do- reinforced concrete structures
20	IS – 3370	Part IV/1965 – do- do- Design tables
21	Test IS – 1199:1959	Sampling & Analyzing of concrete
22	IS – 8142: 1976	Tests for setting time of concrete.
23	IS – 516:1959	Tests for strength of concrete

Sr. No.	IS No.	Description
24	IS - 9013: 1978	Tests for compressive strength
25	IS - 4031	Tests for cement
26 a	1786:1985	High yield strength deformed bar (Grade Fe 415)
26 b	IS - 1786 :1985	For Steel reinforcement
26 c	IS -2751: 1966	Welding of reinforcement
27	IS - 2502:1963	Bending and fixing of bars for concrete
28	IS - 9077:1979	Corrosion protection of steel reinforcement in R.C.C. Structure
29	IS - 2062 : 1992	Structural steel
30	IS - 2062	: (Grade A) Low Carbon structural test
31	IS - 800:	1984 Use of structural steel in general building construction
32	IS - 808: 1989	Rolled steel beams, Channels and angles.
33	Is - 1038 : 1983	Steel doors, windows and ventilators.
34	IS - 7452: 1990	Hot rolled steel section for doors, windows and ventilators
35	IS - 4021:1995	Timber door window and ventilator frames.
36	IS - 1003:1991	Timber panelled and glazed door shutters.
37	IS - 2202:1991	Wooden flush door shutters (solid core type)
38	IS - 2571:1970	Laying inside cement concrete flooring
39	IS - 4457:1982	Ceramic unglazed vitreous acid resisting tiles
40	IS - 777: 1988	Glazed EW wall tiles
41	IS - 7198:1974	Damp proofing using bitumen mastic
42	IS - 1230:1979	CI rain water pipes & fittings
43	IS - 780:1984	Sluice valves for water works purposes. (small dia 50 mm to 300 mm size)
44	IS - 2906:1984	do - (higher dia 350 mm to 1200 mm size)
45	IS - 3950 : 1979	Surface boxes for sluice valves
46	IS - 13095:1991	Butterfly valves for general purposes
47	Is - 12969:1990	Method of test for quality characteristics of valves.
48	IS - 12992:1993	Spring loaded safety relief valves.
49	Is - 5312:1984	Swing check type reflux valves
50	Is - 5330:1984	Design of anchor block for pen shocks with expansion joints
51	IS - 3042:1965	Single faced sluice gate (200 mm - 1200 mm)
52	Is - 1661: 1972	Cement and cement lime plaster finishes
53	IS - 1237:1980	Flooring tiles of cement concrete.
54	IS - 2114: 1984	Laying in situ terrazzo floor finish.
55	IS - 1443:1972	Cement concrete flooring tiles, laying and finishing of.
56	IS - 1609:1991	Laying damp proof treatment using Bituminous felt.

Sr. No.	IS No.	Description
57	IS - 1322:1993	Bitumen felt for water proofing and damp proofing.
58	IS - 7193:1994	Glass fibre base coal tar pitch and bitumen felt.
59	IS - 6494:1988	Water proofing of underground water reservoir and swimming pools.
60	IS - 3067 :1988	General design details and preparatory work for damp proofing and water proofing of building
61	IS - 4082:1996	Stacking of storage of constructional materials at site recommendation
62	IS - 3114:1994	Laying of CI pipes.
63	IS - 1536:1989	Centrifugally cast (spun) iron pressure pipe.
64	IS - 1537: 1976	Vertically cast iron pressure pipe.
65	IS - 1538: 1993	CI fittings for pressure pipe.
66	IS - 7181:1986	DF horizontally cast iron pressure pipe. SI No. IS No. Description
67	IS - 13382:1992	CI special for mechanical end push on flexible joints for pressure pipe.
68	IS - 5382:1985	Rubber sealing rings for water mains.
69	IS - 12820:1989	Dimensional requirements for rubber gasket for mechanical joints & push on joints.
70	IS - 1879: 1987	Malleable CI pipe fittings
71	IS - 782:1978	Caulking lead
72	IS - 11606:	1986 Methods for sampling of CI pipes and fittings
73	IS - 458:1988	Precast concrete pipe
74	IS - 783:1985	Laying of concrete pipes
75	IS - 3597:1985	Method of testing of concrete pipes.
76	IS - 10221:1982	Coating and wrapping of underground mild steel pipe lines.
77	IS - 2974(Part 4)	1979 Foundation for Rotary type machine of low frequency
78	IS - 2911:1979 (Part 1 section 2)	Design and construction of bored cast in situ concrete piles
79	IS - 2911:1985 (Part 4)	Load test on piles
80	IS - 816:	1991 Use of metal arc welding for general construction in mild steel
81	IS - 1024:1979	Welding in bridge and structures subject to dynamic loading.
82	IS - 822: 1970	Procedure for inspection of welds
83	IS - 814:1991	Electrodes for manual metal arc welding
84	IS - 1052:	1983 Specification for collapsible gate
85	IS - 6248:1979	Specification for metal rolling shutter and rolling grill.

Sr. No.	IS No.	Description
86	IS - 7322:1985	Specials for steel cylinder reinforced concrete pipes.
87	IS - 3950:1979	Surface boxes for sluice valves.
88	IS - 5312 (Pt I):1984	Swing check type reflux (non-return, single door) valves
89	IS - 5312(Pt II):1986	- do - (Multi door pattern)
90	IS - 5822:1994	Laying of Electrically welded steel pipes for water supply.
91	IS - 823	Procedure for manual arc welding of mild steel
92	IS - 4353	Submerged arc welding of mild steel and low alloy steels
93	IS - 73 - 07(Pt I)	Approved tests for welding procedures (fusion welding of steel)
94	IS - 7310(Pt I)	Approved tests for welders working to approved welding procedure (Part I: fusion welding of steel)
95	IS - 2595:1978	Code of practice for radiographic testing
96	IS - 4853:1968	Recommended practice for radiographic examination of fusion welded circumferential joints steel pipes
97	IS - 1182:1967	Recommended practice for radiographic examination of fusion welded butt joints.
98	IS - 2598:1966	Safety code for industrial radiographic practice.
99	IS - 5878 (Pt IV)	Code of practice for construction of tunnels conveying water (Part 4 - Tunnel supports)
100	IS - 1363	Technical supply conditions for threaded fasteners
101	IS - 1367 (Pt 3)	Technical supply conditions mechanical properties and test methods for bolts, screws and studs with full load ability.
102	IS - 10028 (Part-II):1981	latest version Transformer
103	Is - 325:1978	up to latest revision Three phase induction motors
104	IS - 2254:1985	up to latest version Vertical motor
105	IS - 8544:1977	up to latest version Starter
106	IS 3043	Earthing
107	IE Rules - 1956 (up to latest version)	All electrical installation will have to be done as per Indian Electrical rules.
108	Manual on Water Supply and Treatment Revised and Updated Edition Central Public Health and Environmental Engineering Organisation , Ministry of Urban Development, New Delhi	All provisions in the manual are binding in both Design and Execution of the work

PROFORMA FOR TESTS CARRIED OUT

NAME OF THE WORK:

DIVISION:**.....

SUB-DIVISION:**.....

AGREEMENT NO. & DATE:

1	2	3	4	5	6	7	8	9	10
Sl. No.	Item	Quantities as per agreement	Frequency as per specification	No. of tests required	R.A. bill No.	Up-to-date quantity	No. of tests required	No. of tests actually done	Remarks

Signature of Contractor

GUIDELINES & GENERAL CONDITIONS

GENERAL CONDITIONS

1. As soon as the tenderer receives tender acceptance letter, he should submit to the Secretary JIADA schedule of construction in the shape of bar chart for all activities, and get this schedule approved from the Secretary . This schedule should be submitted before stipulated date of start of construction.
2. During the course of work the contractor will have to maintain constant coordination with Electrical and Air-conditioning work such that every type of work goes smoothly.
3. Dimensions in drawings and specification may be taken in millimetre unless otherwise mentioned.
4. All holes in RCC, brick work etc. will be made by using power Drill of appropriate size and not by using Hammer / Chisel etc. unless specifically allowed by the Secretary .
5. Finished work shall be finally tested for acceptance by a team of the department, within six months from the recorded date of completion. The contractor will have to provide, without any charge labour and facilities for this acceptance testing (A/T), whenever required. He will have to set right all defective work pointed out during the course of A/T or at any other time.

Sd/-
Secretary,
JIADA,
3rd floor, New JIADA Building,
Industrial area, Namkum,

**SECTION 6
FORM OF BID**

FORM OF BID

Description of the Works:

BID

To :

Address :

1. We offer to execute the Works described above and remedy any defects therein in conformity with the conditions of Contract, specification, drawings, Bill of Quantities and Addenda for the sum(s) of

(_____)

2. We undertake, if our Bid is accepted, to commence the Works as soon as is reason-ably possible after the receipt of the Engineer's notice to commence, and to com-plete the whole of the Works comprised in the Contract within the time stated in the document.
3. We agree to abide by this Bid for the period of * ____ days from the date fixed for receiving the same, and it shall remain binding upon us and may be accepted at any time before the expiration of that period.
4. Unless and until a formal Agreement is prepared and executed this Bid, together with your written acceptance thereof, shall constitute a binding contract between us.
5. We understand that you are not bound to accept the lowest or any tender you may receive.

Dated this _____ day of _____ 20....

Signature _____ in the capacity of ____

duly authorized to sign bids for and on behalf of _____

(in block capitals or typed)

Address

Witness

Address

Occupation

SECTION 7
BILL OF QUANTITIES

SECTION 8
SECURITIES AND OTHER FORMS

BID SECURITY (BANK GUARANTEE)

WHEREAS, _____ [name of Bidder] (hereinafter called "the Bidder") has submitted his Bid dated _ [date] for the construction of _____ [name of Contract hereinafter called "the Bid"].

KNOW ALL PEOPLE by these presents that We _____ [name of Bank] of _____ [name of country] having our registered office at _____ (hereinafter called "the Bank") are bound unto _____ [name of Employer's Representative] (hereinafter called "the Employer's Representative") in the sum of _____ * for which payment well and truly to be made to the said Employer's Representative the Bank itself, his successors and assigns by these presents.

SEALED with the Common Seal of the said Bank this _____ day of _____, 20_

THE CONDITIONS of this obligation are:

(1) If after Bid opening the Bidder withdraws his bid during the period of Bid validity specified in the Form of Bid;

OR

(2) If the Bidder having been notified to the acceptance of his bid by the Employer during the period of Bid Validity:

- (a) fails or refuses to execute the Form of Agreement in accordance with the Instructions to Bidders, if required; or
- (b) fails or refuses to furnish the Performance Security, in accordance with the Instructions to Bidders; or
- (c) does not accept the correction of the Bid Price pursuant to Clause 27.

We undertake to pay to the Employer up to the above amount upon receipt of his first written demand, without the Employer having to substantiate his demand, provided that in his demand the Employer will note that the amount claimed by him is due to him owing to the occurrence of one or any of the three conditions, specifying the occurred condition or conditions.

This Guarantee will remain in force up to and including the date _____ ** days after the deadline for submission of Bids as such deadline is stated in the Instructions to Bidders or as it may be extended by the Employer, notice of which extension(s) to

the Bank is hereby waived. Any demand in respect of this guarantee should reach the Bank not later than the above date.

DATE _____

SIGNATURE _____

WITNESS _____

SEAL _____

[Signature, name and address]

* The Bidder should insert the amount of the guarantee in words and figures denominated in Indian Rupees. This figure should be the same as shown in Clause 16.1 of the Instructions to Bidders.

** 45 days after the end of the validity period of the Bid. Date should be inserted by the Employer before the Bidding documents are issued.

PERFORMANCE BANK GUARANTEE

To

_____ [name of Employer's Representative]

_____ [address of Employer's Representative]

WHEREAS _____, _____ [name and address of Contractor]
(hereafter called "the Contractor") has undertaken, in pursuance of Contract No.

dated _____ to execute _____ [name of Contract and brief
description of Works] (hereinafter called "the Contract").

AND WHEREAS it has been stipulated by you in the said Contract that the Contractor shall furnish you with a Bank Guarantee by a recognized bank for the sum specified therein as security for compliance with his obligation in accordance with the Contract;

AND WHEREAS we have agreed to give the Contractor such a Bank Guarantee:

NOW THEREFORE we hereby affirm that we are the Guarantor and responsible to you on behalf of the Contractor, up to a total of _____ [amount of guarantee]* _____ (in words), such sum being payable in the types and proportions of currencies in which the Contract Price is payable, and we undertake to pay you, upon your first written demand and without cavil or argument, any sum or sums within the limits of _____ [amount of guarantee] as aforesaid without your needing to prove or to show grounds or reasons for your demand for the sum specified therein.

We hereby waive the necessity of your demanding the said debt from the contractor before presenting us with the demand.

We further agree that no change or addition to or other modification of the terms of the Contract or of the Works to be performed there under or of any of the Contract documents which may be made between your and the Contractor shall in any way release us from any liability under this guarantee, and we hereby waive notice of any such change, addition or modification.

This guarantee shall be valid until 28 days from the date of expiry of the Defect Liability Period.

Signature and Seal of the guarantor _____

Name of Bank _____

Address _____

Date _____

*An amount shall be inserted by the Guarantor, representing the percentage the Contract Price specified in the Contract including additional security for unbalanced Bids, if any and denominated in Indian Rupees.

BANK GUARANTEE FOR ADVANCE PAYMENT

To

_____ [name of Employer's Representative]
_____ [address of Employer's Representative]
_____ [name of Contractor]

Gentlemen:

In accordance with the provisions of the Conditions of Contract, sub-clause 51.1 ("Advance Payment") of the above-mentioned Contract, [name and address of Contractor] (herein after called "the Contractor") shall deposit with [name of Employer's Representative] a bank guarantee to guarantee his proper and faithful performance under the said Clause of the Contract in an amount of _____ [amount of Guarantee]* _____ [in words].

We, the _____ [bank of financial institution], as instructed by the Contractor, agree unconditionally and irrevocably to guarantee as primary obligator and not as Surety merely, the payment to _____ [name of Employer's Representative] on his first demand without whatsoever right of obligation on our part and without his first claim to the Contractor, in the amount not exceeding _____ [amount of guarantee]* _____ [in words].

We further agree that no change or addition to or other modification of the terms of the Contractor or Works to be performed there under or of any of the Contract documents which may be made between _____ [name of Employer's Representative] and the Contractor, shall in any way release us from any liability under this guarantee, and we hereby waive notice of any such change, addition or modification.

This guarantee shall remain valid and in full effect from the date of the advance payment under the Contract until _____ [name of Employer's Representative] receives full repayment of the same amount from the Contractor.

Yours truly,

Signature and Seal : _____

Name of Bank / Financial Institution : _____

Address; _____

Date:

*An amount shall be inserted by the Bank or Financial Institution representing the amount of the Advance Payment, and denominated in Indian Rupees.

Letter of Acceptance

(Letter head paper of the Employer's Representative)

_____ (Date)

To

_____ (Name and address of the Contractor)

Dear Sirs,

This is to notify you that your Bid dated _____ for execution of the _____ (name of the contract and identification number, as given in the Instructions to Bidders) for the Contract Price of Rupees _____ (_____) (amount in words and figures), as corrected and modified in accordance with the Instructions to Bidders¹ is hereby accepted by our agency.

You are hereby requested to furnish Performance Security, in the form detailed in Para 34.1 of ITB for an amount equivalent to Rs. _____ within 21 days of the receipt of this letter of acceptance valid up to 28 days from the date of expiry of defects

Liability Period i.e. up to _____ and sign the contract, failing which action as stated in Para 34.3 of ITB will be taken.

Yours faithfully,

Authorized Signature
Name and title of Signatory
(Employer's Representative)

1. Delete "corrected and" or "and modified" if only one of these actions applies. Delete as corrected and modified in accordance with the Instructions to Bidders, if corrections or modifications have not been affected.

Issue of Notice to proceed with the work
(Letter head of the Employer's Representative)

_____ (Date)

To

Contractor)

(Name and address of the

Dear Sirs,

Pursuant to your furnishing the requisite security as stipulated in ITB Clause 34.1 and signing of the Contract for the construction of

_____ at a Bid Price of
Rs. _____.

You are hereby instructed to proceed with the execution of the said works in accordance with the contract documents.

Yours faithfully,

(Signature, name and title of Employer's Representative)

Agreement Form

Agreement

This agreement, made the _____ day of _____ between _____ (name and address of Employer) [hereinafter called "the Employer] and _____ (name and address of contractor) hereinafter called "the Contractor" of the other part.

Whereas the Employer is desirous that the Contractor execute

_____ (name and identification number of Contract) (hereinafter called "the Works") and the Employer has accepted the Bid by the Contractor for the execution and completion of such Works and the remedying of any defects therein , at a cost of Rs. _____

NOW THIS AGREEMENT WITNESSETH as follows :

1. In this Agreement, words and expression shall have the same meanings as are respectively assigned to them in the conditions of contract hereinafter referred to and they shall be deemed to form and be read and construed as part of this Agreement.
2. In consideration of the payments to be made by the Employer to the Contractor as hereinafter mentioned, the Contractor hereby covenants with the Employer to execute and complete the Works and remedy any defects therein in conformity in all aspects with the provisions of the contract.
3. The Employer hereby covenants to pay the Contractor in consideration of the execution and completion of the Works and the remedying the defects wherein Contract Price or such other sum as may become payable under the provisions of the Contract at the times and in the manner prescribed by the Contract.
4. The following documents shall be deemed to form and be ready and construed as part of this Agreement viz.
 - (i) Letter of Acceptance
 - (ii) Notice to proceed with the works;
 - (iii) Contractor's Bid
 - (iv) Condition of Contract: General and Special
 - (v) Contract Data
 - (vi) Additional condition
 - (vii) Drawings
 - (viii) Bill of Quantities and
 - (ix) Any other documents listed in the Contract Data as forming part of the Contract.

In witnessed whereof the parties there to have caused this Agreement to be executed the day and year first before written.

The Common Seal of _____ was here unto affixed in the presence of :

Signed, Sealed and Delivered by the said _____

in the presence of:

Binding Signature of Employer's Representative _____

Binding Signature of Contractor _____

UNDERTAKING

I, the undersigned do hereby
undertake that our firm M/s
_____ agree to abide by this bid for a period
_____ days for the date fixed for receiving the same and it shall be
binding on us and may be accepted at any time before the expiration of
that period.

(Signed by an Authorized Officer of the Firm)

Title of Officer

Name of Firm

DATE

Affidavit

I,.....S/o.....Address.....
.....of (Name of the firm) do here by
solemnly affirm as follow:

1. That all papers submitted by me in the SBD of e-tender reference numberdated..... for(Name of work) is correct to the best of my knowledge. At any stage if it, is found that the information given is not genuine or any of the papers submitted by me is not correct, department is free to forfeit my EMD and may initiate process of blacklisting against the firm.
2. That I have read the Bid document and I am accepting all terms and condition as mentioned in it.
3. That no near relative (Husband/Wife/Mother/Father/Own Brother or Sister) is working as Accountant or Junior Engineer or higher of this post in this JIADA office Ranchi, Jharkhand.
4. That I/my firm/company is not black listed or debarred anywhere.

Sworn and signed on.....I.....do hereby declare that
above statements are true and correct.

Deponent

Identified by

Annexure- I
FORMAT FOR UNDERSTANDING THE PROJECT SITE

I/we hereby certify that I/we have examined & inspected the site & its surrounding satisfactorily, where the project is to be executed as per the scope of works. I/ We are well aware about the Location and conditions etc.

I / We hereby submit our BID considering above all facts gathered during site visit and each & every aspect has been considered in the Quoted cost of the project as per BOQ.

1. Name of Bidder Representative with Designation visited the site: -
.....;

2. Name of Bidder/Firm:-.....

3. Tender to be participated by Bidder:- **Construction of Basic Infrastructures (Such as Roads, drain, Utility duct, Street Light etc) of international Level for Hazaribagh industrial Area JIADA.**

4. Name & Location of Site visited with dates: -

a) _____ on _____

b) _____ on _____ Please add on as required

(Name with designation)

Representative of the Agency/Firm

(Name with designation)

SECTION 9
DRAWINGS

SECTION 10

DOCUMENTS TO BE FURNISHED BY BIDDER

Refer to Addendum to ITB

ADDENDUM
To
Instructions to Bidders (ITB)
(FOR JHARKHAND SBD CONTRACT)

A. Detailed instructions & documents to be furnished for online bidding

1. Guidelines for online submission of bids can be downloaded from the website <http://jharkhandtenders.gov.in>
 2. Interested bidders can download the bid from the website <http://jharkhandtenders.gov.in>
 3. Bidders in order to participate in the bidding process have to get 'Digital Signature Certificate (DSC) as per Information Technology Act-2000 to participate in online bidding. This certificate will be required for digitally signing the bid. Bidders can get the above mentioned digital signature certificate from any approved vendors (CCA). Bidders, who already possess valid Digital Certificates, need not procure new Digital Certificate.
 4. Bidders have to submit their bids online in electronic format with digital Signature. Bids without digital signature will not be accepted. No proposal will be accepted in physical form.
 5. Bids will be opened online as per time schedule mentioned in the Invitation for Bids (IFB).
 6. Deleted
 7. Uploaded documents of successful bidder will be verified with the original before signing the agreement. The successful bidder has to provide the originals to the concerned authority.
 8. The department will not be responsible for any delay in online submission due to any reason whatsoever. No claim shall be entertained on account of disruption of internet services being used by the bidder. Bidders are advised to upload their bids well in advance to avoid last minute technical snags.
 9. All required information for bid must be filled and submitted online.
 10. Other details can be seen in the bidding documents.
 11. Only online withdrawal or modification of bids, if any, in pursuance of relevant clauses of the SBD is acceptable.
- B. Details of documents to be furnished for online bidding**
1. Scanned copies of the following documents to be up-loaded in pdf format on the website <http://jharkhandtenders.gov.in> in technical bid folder.
 - I. Qualification information and supporting documents as specified in Section-2 of SBD.
 - II. Certificates, undertakings, affidavits as specified in Section-2.
 - III. Any other information pursuant to Clause-4.2 of ITB.
 - IV. Undertakings that the bid shall remain valid for the period specified in Clause-15.1 of ITB.

5. Scanned copies of the following documents to be up-loaded on the website <http://jharkhandtenders.gov.in> in financial bid folder.
 - i. Form of bid has specified in Section-6 in pdf format.
6. Duly filled in & digitally signed BOQ in financial bid folder.
7. Uploaded documents of successful bidder will be verified with the original before signing the agreement. The successful bidder has to provide the originals to the concerned authority on receipt of such a letter, which will be sent through registered post or speed post or delivered by hand.
8. SBD is not to be uploaded by the bidder. The bidder has to give affidavit stating agree/disagree on the conditions in the SBD. The bidder, who disagrees on the conditions of SBD, cannot participate in the tender
9. Each uploading shall be digitally signed by the bidders.
10. Corrigendum/ Addendum/ rectifications, if any, will be published only in the website <http://jharkhandtenders.gov.in>

Sd/-

Secretary,
JIADA,
3rd floor, New JIADA Building,
Industrial area, Namkum,

Clause No.	As mentioned in the Part I: Complete Bidding Document of Standard Bidding Document -Procurement of Civil works	Text to be substituted as under
Section 1-ITB:Cl 8.2	One copy of each of the volumes I, II, II and IV will be issued to the bidder. Documents to be furnished by the bidder in compliance to section 2 will be prepared by him and furnished as Volume-V in two parts(refer clause 12)	Each of the volumes I, II, II and IV will be available online on website http://jharkhandtenders.gov.in for bidder(s). Documents to be submitted by the bidder(s) in compliance to section 2 will be prepared by him and submitted online as per instruction given in addendum to ITB.
Section 1-ITB:Cl 12.1	The bid to be submitted by the bidder as Volume V of the bid document(refer clause 8.1) shall be in two separate parts: Part I shall be named “Technical Bid “ and shall comprise i. Bid security in the form specified in Section 8 i. Qualification Information and supporting documents as specified in Section 2. i. Certificates, undertaking, affidavits as specified in section2. v. Any other information pursuant to clause 4.2 of these instructions v. Undertaking that the bid shall remain valid for the period specified in clause 15.1 Part II shall be named “Financial Bid” and shall comprise i. Form of Bid as specified in section 6 i. Priced Bill of Quantities for items specified in section 7, each part will be separately sealed and marked in accordance with the sealing and marking instructions in clause 19.	The bid shall be submitted by the bidder on line as per instruction contained in addendum to ITB.
Section 1-ITB Clause - 12.2	The bidder shall prepare two copies of the bid, marking them ‘original’ and ‘Copy’ respectively.	The bid shall be submitted by the bidder on line as per instruction contained in addendum to ITB.
Section 1-ITB Clause - 13.2	The bidder shall fill in rates and prices and line item total (both in figures and words) for all items of the Works described in the Bill of Quantities along with total bid price (both in figures and words). Items for which no rate or price is entered by the bidder will not be paid for by the Employer when executed and shall be deemed covered by the other rates and prices in the Bill of Quantities. Corrections, if any, shall be made by crossing out, initialing,	The bidder shall fill in rates in figures only as the rate in words will be generated automatically in the BOQ template. Items for which no rate or price is entered by the bidder will not be paid for by the Employer when executed and shall be deemed covered by the other rates and prices in the Bill of Quantities.

	dating and rewriting.	
Section 1-ITB Clause - 18.1	The bidder shall prepare one original and one copy of the documents comprising the bid as described in Clause 12 of these Instructions to Bidders, bound, with the volume containing the "Technical Bid" and "Financial bid" in separate parts and clearly marked " ORIGINAL " and " COPY " as appropriate. In the event of discrepancy between them, the original shall prevail.	The bidder shall submit the bids as per addendum to ITB .
Section 1-ITB Clause - 18.2	The original and copy of the Bid shall be typed or written in indelible ink and shall be signed by a person or persons duly authorized to sign on behalf of the Bidder, pursuant to Sub-Clauses 4.3. All pages of the bid where entries or amendments have been made shall be initialled by the person or persons signing the bid.	The bidder shall submit the bids as per addendum to ITB . Bids submitted online have to be digitally signed by the bidder.
Section 1-ITB Clause - 18.3	The Bid shall contain no alterations or additions, except those to comply with instructions issued by the Employer, or as necessary to correct errors made by the bidder, in which case such corrections shall be initialled by the persons signing the bid.	Bidders shall follow the method of submission of bid as mentioned in addendum to ITB
Section 1-ITB Clause - 19.1	The Bidder shall seal the original and copy of the Bid in separate envelopes, duly marking the envelopes as " ORIGINAL " and " COPY ". These two envelopes (called as inner envelopes) shall then be put inside one outer envelope. Each set of the inner envelope marked "ORIGINAL" and "COPY" shall contain within it two separate sealed envelopes marked "Technical Bid" and "Financial Bid" with additional markings as follows :	Bidders shall follow the method of submission of bid as mentioned in addendum to ITB
Section 1-ITB Clause - 19.2	The inner, outer, and separate envelopes containing Technical and Financial Bids shall (a) Be addressed to the Employer at the address given in Appendix (b) Bear the identification as indicated in Appendix.	Bidders shall follow the method of submission of bid as mentioned in addendum to ITB
Section 1-ITB Clause - 19.3	In addition to the identification required in sub-clauses 19.1 and 19.2, each of the envelopes shall indicate the name and address	Bidders shall follow the method of submission of bid as mentioned in addendum to ITB

	of the bidder to enable the bid to be returned unopened in case it is declared late, pursuant to clause 21, or the Evaluation Committee declares the bid as non responsive pursuant to clause 23.	
Section 1-ITB Clause - 19.4	If the outer envelope is not sealed and marked as above, the Employer will assume no responsibility for the misplacement or premature opening of the bid.	Bidders shall follow the method of submission of bid as mentioned in addendum to ITB
Section 1-ITB Clause - 20.1	Complete Bids (including Technical and Financial) must be received by the employer at the address specified above not later than the date indicated in appendix. In the event of the specified date for the submission of bids declared a holiday for the Employer, the bids will be received up to the appointed time on the next working day.	Bidders shall follow the method of submission of bid as mentioned in addendum to ITB
Section 1-ITB Clause - 22.2	Each Bidder's modification or withdrawal notice shall be prepared, sealed, marked, and delivered in accordance with clause 18 & 19, with the outer and inner envelopes additionally marked " MODIFICATION " or " WITHDRAWAL ", as appropriate.	Bidders shall follow the method of submission of bid as mentioned in addendum to ITB
Section 1-ITB Clause- 23.1	The Employer will open all the Bids received (except those received late), including modification made pursuant to Clause 22, in the presence of the Bidders or their representatives who choose to attend at time, date and the place specified in Appendix in the manner specified in Clause 20 and 23.3. In the event of the specified date of Bid opening being declared a holiday for the Employer, the Bids will be opened at the appointed time and location on the next working day.	The Employer will open all the Bids submitted online including modification made pursuant to Clause 22, in the presence of the Bidders or their representatives who choose to attend at time, date and the place specified in Appendix in the manner specified in Clause 20 and 23.3. In the event of the specified date of Bid opening being declared a holiday for the Employer, the Bids will be opened at the appointed time and location on the next working day. A notice for the same shall be posted on the website.
Section 1-ITB Clause- 23.2	Envelopes marked "WITHDRAWAL" shall be opened and read out first. Bids for which an acceptable notice of withdrawal has been submitted pursuant to clause 22 shall not be opened.	Withdrawn bids shall be opened and read out first. Bids for which an acceptable notice of withdrawal has been submitted pursuant to clause 22 shall not be opened.
Section 1-ITB Clause- 23.3	The envelope containing "Technical bid" shall be opened. The amount, form and validity of the bid security furnished with each bid will be announced. If the bid security furnished does	"Technical bid" shall be opened first. The amount, form and validity of the bid security furnished with each bid will be announced. If the bid security

	not conform to the amount and validity period as specified in the Invitation for Bid (ref. Column 4 and paragraph 3), and has not been furnished in the form specified in Clause 16, the remaining technical bid and the sealed financial bid will be returned to the bidder.	furnished does not conform to the amount and validity period as specified in the Invitation for Bid (ref. Column 4 and paragraph 3), and has not been furnished in the form specified in Clause 16, the said bid shall not be opened/ processed further.
Section 1-ITB Clause-23.4 (ii)	After receipt of confirmation of the bid security, the bidder will be asked in writing (usually within 10 days of opening of the Technical Bid) to clarify or modify his technical bid, if necessary, with respect to any rectifiable defects.	After receipt of confirmation of the bid security, the bidder will be asked in writing/e-mail (usually within <u>10 days</u> of opening of the Technical Bid) to clarify or modify his technical bid, if necessary, with respect to any rectifiable defects.
Section 1-ITB Clause-23.4 (iii)	The bidders will respond in not more than 7 days of issue of the clarification letter, which will also indicate the date, time and venue of opening of the Financial Bid (usually on the 21 st day of opening of the Technical bid)	The bidders will respond by e-mail in not more than <u>7 days</u> of issue of the clarification letter, which will also indicate the date, time and venue of opening of the Financial Bid (usually on the <u>21st day</u> of opening of the Technical bid)
Section 1-ITB Clause-23.5	If, as a consequence of the modifications carried out by the bidder in response to sub-clause 23.4, the bidders desire to modify their financial bid, they will submit the modification in separate sealed envelope so as to reach the Employer's address (refer sub-clause 19.2) before the opening of the financial bid as intimated in the clarification letter (refer sub-clause 23.4). The envelope shall have clear marking "MODIFICATION TO FINANCIAL BID, Not to be opened except with the approval of the Evaluation Committee"	If, as a consequence of the modifications carried out by the bidder in response to sub-clause 23.4, the bidders desire to modify their financial bid, they will submit the modification online before the opening of the financial bid as intimated in the clarification letter (refer sub-clause 23.4).
Section 1-ITB Clause-23.6	At the time of opening of "Financial Bid", the names of the bidders were found responsive in accordance with Clause 23.4(iv) will be announced. The bids of only these bidders will be opened. The remaining bids will be returned to the bidders unopened. The responsive Bidders' names, the bid prices, the total amount of each bid, any discounts, Bid Modifications and withdrawals, and such other details as the Employer may consider appropriate, will be announced by the Employer at the opening. Any Bid price or discount, which is not read out and recorded	At the time of opening of "Financial Bid", the names of the bidders found responsive in accordance with Clause 23.4(iv) will be announced. The bids of only these bidders will be opened. The remaining bids will remain unopened. The responsive Bidders' names, the bid prices, the total amount of each bid, any discounts, Bid Modifications and withdrawals, and such other details as the Employer may consider appropriate, will be announced by the Employer at the

	will not be taken into account in Bid Evaluation.	opening. Any Bid price or discount, which is not read out and recorded will not be taken into account in Bid Evaluation.
--	---	--

Sd/-
Secretary,
JIADA,
3rd floor, New JIADA Building,
Industrial area, Namkum,

CHECK LIST

e-TENDER REFERENCE NO. :-

Name of Work:-

Name of Bidder (to be filled by bidder) :-

Sl. No.	Particulars	Expected Value	Bidders value (to be filed by bidder)	Page No. of documents supporting technical qualification (to be filled by bidder)
1	AFFIDAVITS	Yes		
2	Affidavit regarding acceptance of Terms and Conditions given in SBD Contract attached	Yes		
3	Auditor Report for Last 5 (FIVE) years attached	Yes		
4	Whether Form of Bid submitted.	Yes		
5	Availability of Key Plants and Equipments	Yes		
6	Whether List of Key Plant and Equipment to be deployed on Contract Work (SBD Annexure-I, (reference Cl. 4.5 B (a)) attached.	Yes		
7	Availability of Technical Personnel	Yes		
8	Whether List of Key Personal to be deployed on Contract Work (SBD Annexure-(reference Cl. 4.5 B (b)) attached.II,	Yes		
9	BANKER DETAIL	Yes		
10	Liquid Assets/ Credit Facilities Amount	Yes		
11	Reference to Banker Attached	Yes		
12	BID CAPACITY	Yes		
13	Bid Capacity using formula- $A \times N \times 2 - B$	Yes		
14	BID SECURITY	online		
15	Bid Security Amount	Yes		
16	Validity Period of the Bid Security (in DAYS)	120		
17	Constitutional and Legal Status of Bidder	Yes		

18	Type 1 for Private Limited, 2 for Joint Venture, 3 for Partnership firm, 4 for others.			
19	Whether documents defining constitution or legal status attached.	Yes		
20	Electrical License.	Yes		
21	Whether updated Electrical License is available Type 1 for NOT Available Type 2 for self license Type 3 for other person license.			
22	Experience in terms of Monetary value			
23	Refer to SBD Instructions to Bidders Clause 4.5 A (II) for contract value Above Rs. 50 crores	Yes		
24	Employer's certificate in support of completion of Project.	Yes		
24	INCOME TAX			
25	5 Years Auditors Report Attached	Yes		
26	Whether PAN card attached.	Yes		
27	Litigation Details.	Yes		
28	Litigation History.	Yes		
29	Quality Assurance	Yes		
30	Quality Assurance Program attached.	Yes		
31	Quantity of item of Work executed in any ONE WORK during last five year.	Yes		
32	Electrical Works	Yes		
33	Site Visits	Yes		
34	Quantity of Items of WORK executed in any ONE YEAR during last 5 (five) years	Yes		
35	Brick (in Cum)	---		
36	Cement Concrete (RCC & PCC work) (in Cum)	Yes		
37	Earth Work in Excavation (in Cum).	Yes		
38	Registration Details	Yes		

39	Document regarding registration with BCD attached Type 1 for Jharkhand, 2 for Central Govt., 3 other State Govt., 4 for PSU.	1		
40	GST			
41	Whether GST Certificate attached.	Yes		
42	Tender Fee			
43	Cost of Bidding Document (IFB) in Rupee.	online		
44	Whether Tender Fee submitted confirms the guidelines of SBD.	Yes		
45	Turn Over Detail	Yes		
46	Annual Financial Turnover (MAXIMUM) in any ONE year during last five years.	-----		
47	UNDERTAKING			
48	Bidder is NOT associated with Consultant.	Yes		
49	Bidder undertaking of 25 percent case investment during implementation of work Attached.	Yes		
50	Whether Certificate of hiring/ leasing the required plants and Machineries, which is not possessed by the Contractor Attached.	Yes		
51	Whether Power of Attorney of Signatory of Bid Attached	Yes		
52	Whether Check list attached.	Yes		
53	Whether Proposal regarding subcontracting and firm involved is attached.	Yes		
54	Whether UCAN is attached.	Yes		
55	Whether Undertaking to abide by this Bid for a Period of 120 days attached.	Yes		
56	Whether updated Character Certificate Attached.	Yes		
57	Whether updated Employee Provident Fund Certificate is attached.	Yes		
58	WORK PLAN AND METHODOLOGY			
59	Proposed Methodology and Program backed with equipment planning and deployment, broad calculation, QC Procedures Attached.	Yes		

Sd/-
Secretary,
 JIADA,
 3rd floor, New JIADA Building,
 Industrial area, Namkum,

ARTICLE 1

GENERAL ASPECTS

1.1. **General** : Frequency of culverts and small bridges varies depending upon the region and terrain. The location, size and other details of such structures should be decided judiciously to cater for the discharge and balancing requirements. Number of culverts in 1 km length of road in India varies from one (flat country) to three in undulating regions whereas one small bridge (upto 30 m) is found within 1 to 4 km length of the road. Number of culverts may increase in hilly/undulating terrain.

1.2. Definitions

1.2.1. **Bridges** : Bridge is a structure having a total length above 6 m between the inner faces of the dirt walls for carrying traffic or other moving loads over a depression or obstruction such as channel, road or railway.

1.2.2. **Minor Bridge** : A minor bridge is a bridge having a total length of upto 60 m.

1.2.3. **Small Bridge** : A small bridge is a bridge where the overall length of the bridge between the inner faces of dirt walls is upto 30 m and where individual span is not more than 10 m.

1.2.4. **Culvert** : Culvert is a cross-drainage structure having a total length of 6 m or less between the inner faces of the dirt walls or extreme ventway boundaries measured at right angles thereto.

1.2.5. The Small Bridges and Culverts can be of following types:

- a) RCC Hume Pipes
- b) RCC slab on masonry/concrete abutment and piers
- c) Stone slab on masonry/concrete abutment and piers
- d) RCC box cell structure
- e) RCC/masonry arches on masonry/concrete abutment and piers

Stone slabs can be used upto 2 m span when good quality stones with 200 mm thickness are available.

1.3. Standard Designs

1.3.1. **MORT&H standard design for slab bridges** : Ministry of Road Transport & Highways (MORT&H) in standard design of slab bridges have proposed round figures for design span (c/c of supports). With a view to avoid confusion, same nomenclature of span is considered for culverts and small bridges. The design span of 6 m will have clear span of 5.60 m. The values of clear span, effective span and end to end of deck for which standard designs of slab bridges are available in Table 1.1.

Similarly type plans of MORT&H are available for skew slab bridges for right effective spans of 4 m, 6 m, 8 m and 10 m for skew angles of 15°, 22.5°, 30° and 35°.

Note :- In case of any ambiguity, the provisions changed vide sankalp no. 2146 (s) dated 09.09.2020 attached below shall be applicable.

झारखंड सरकार
पथ निर्माण विभाग, राँची।

संकेत संख्या :- 40नि0वि0/विधि-06-33/2007(अम-1) - 2146(s) राँची, दिनांक - 09/09/2020

संकल्प

विषय:- लोक निर्माण के कार्यों के सुचारु कार्यान्वयन हेतु सम्बन्धित पद्धति की एकरूपता हेतु प्रावधानों के संशोधन के संबंध में।

राज्य सरकार अन्तर्गत निर्माण शाखाओं के पदाधिकारियों के प्रशासनिक एवं कार्यपालक कृत्यों को निर्धारित करने हेतु झारखण्ड लोक निर्माण विभाग संहिता-2012 मंत्रिपरिपत्र की स्वीकृति उपरान्त राज्य में प्रभूत है।

अभियंत्रण कार्यों के कार्यान्वयन पद्धति के सन्दर्भ में यह पाया जाता है कि कतिपय प्रसंगों में विस्तृत व्याख्या ना होने के कारण अलग-अलग विभाग, कार्यपालक आदेश/परिपत्र द्वारा सुविधानुसार प्रावधान कर लेते हैं। एक ही राज्य में विभागवार अभियंत्रण कार्यों के निमित्त भिन्न पद्धति होने की वजह से क्रियान्वयन में भ्रम की स्थिति उत्पन्न होने की सम्भावना हो जाती है।

सम्बन्धित विधायोपरान्त लोक निर्माण के कार्यों के सुचारु कार्यान्वयन हेतु निम्नलिखित प्रभूत नियम/पद्धति में संशोधन किया जाता है :-

2 (i) निविदाओं में न्यूनतम निविदित दर के संबंध में :-

क्र०	वर्तमान में प्रभूत नियम/पद्धति	संशोधन
1	Jharkhand PWD Code, Clause 163(a) Tenders quoted below 10 (ten) % of the amount mentioned in Bill of Quantity shall be rejected ab initio.	झारखण्ड लोक निर्माण विभाग संहिता की कड़िका-163(a) द्वारा कृत प्रावधान को अव्यक्तित करते हुए 10 प्रतिशत की न्यूनतम अधिसीमा को समाप्त किया जाता है। सम्प्रति 10 प्रतिशत से नीचे के दर की निविदायें अनुमान्य होंगी। साथ ही JPWD Code के clause 163(a) को "delete" किया जाता है। 10 (दस) प्रतिशत से न्यून निविदाओं के लिए Additional Performance Security के क्रम में परिमाण विपत्र की राशि से - (i) 10 से 20 प्रतिशत below तक की राशि का 20% तथा (ii) 20 प्रतिशत से अधिक below की राशि का 30% अतिरिक्त जमानत का प्रावधान लागू होगा। यह झारखण्ड लोक निर्माण विभाग संहिता के नियम 172(a) के रूप में समाहित होगा। पूर्व के संहिता/नियम/परिपत्र द्वारा कृत सभी प्रावधान अव्यक्तित समझे जायेंगे।

2 (ii) समान दर की निविदाओं के निष्पादन के संबंध में :-

क्र०	वर्तमान में प्रभूत नियम/पद्धति	संशोधन
2	(i) मंत्रिमंडल निर्गमन, तकनीकी परीक्षण कोषांग, बिहार, पटना का ज्ञापक-254 दि०	वेब एवं समान दर की निविदाओं के मामले में निविदा निष्पादन के प्राधिकार द्वारा पारदर्शी

पर समान हो, तब उनमें जो पहले निर्बंधित हो, उन्हें प्रथमिकता दी जाय। परन्तु कार्य आवंटन पदाधिकारी द्वारा एक वित्तीय वर्ष में किसी संवेदक को एक से अधिक...

24.02.86 की कडिका-1.12 द्वारा निर्धारित प्रावधान -

निगरानी विभाग के पत्रांक-2347 दिनांक 31.12.83 की कडिका-5(क) में आंशिक संशोधन कर यह उपबंध किया जाता है कि (1) वरीयता के आधार पर बराबर के निविदादाताओं में वरीय निविदादाता को एक वित्तीय वर्ष में एक कार्य के लिये ही प्राथमिकता मिलेगी, और (2) जिस श्रेणी में एक तीकैदार निर्बंधित हो उस श्रेणी से मात्र एक श्रेणी भीरे तक के कार्य बराबर की निविदा की शक्ति ही उन्हें प्राथमिकता दी जायेगी।

वरीयता के आधार जिस श्रेणी की निविदा विधाराधीन हो उस श्रेणी में रजिस्ट्रेशन की तिथि होगी। यदि कोई संवेदक अपने वर्तमान निबंधन की श्रेणी से एक श्रेणी नीचे भी निविदा देते हैं और यदि वे इसके पूर्व वर्तमान श्रेणी से नीचे की श्रेणी में निर्बंधित थे तो उसकी वरीयता की गणना नीचे की श्रेणी में निबंधन की तिथि के आधार पर की जा सकती है। शर्त कि विधाराधीन कार्य उस क्षेत्र में पड़ता हो जिस क्षेत्र के लिये वे निर्बंधित हैं।

(ii) मंत्रिमंडल (निगरानी विभाग), बिहार सरकार, पटना का संकल्प/पत्रांक-2808/निग दि०- 13.09.2001 द्वारा कृत प्रावधान -

राज्य के कार्य विभागों के साथ-साथ अन्य विभागों के अधीन कार्यरत अभियंत्रण कौषांग में पूर्व से प्रदत्त अभियंत्रण कार्य के कार्यान्वयन की पद्धति से सम्बद्ध अनुदेशों/ परिपत्रों के सम्यक् विचारोपरान्त स्थानीय सम्येदकों को लाभ देने के उद्देश्य से सरकार ने निम्नलिखित निर्णय लिया है:-

(i) निगरानी विभाग के पत्रांक-2347 दिनांक 31.12.83 की कडिका 5 तथा ज्ञापक 254 दिनांक 24.02.86 द्वारा निर्गत संकल्प की कडिका 1.12 के अवक्रमण में यह उपबंध किया जाता है कि किसी निविदा के लिए यदि एक से अधिक निविदाकारों की दरें न्यूनतम और समान हो तथा शर्त भी समान हो, तब स्थानीय निविदाकार को प्राथमिकता दी जाय। यदि एक से अधिक स्थानीय निविदाकार की दरें समान हो, तब उनमें जो पहले निर्बंधित हो, उन्हें प्रथमिकता दी जाय। परन्तु कार्य आवंटन पदाधिकारी द्वारा एक वित्तीय वर्ष में किसी संवेदक को एक ही कार्य के लिए स्थनीय होने

तरीके से लालची (lottery) की पद्धति अपनायी जायेगी।

यह प्रावधान, झारखण्ड लोक निर्माण विभाग संहिता के कडिका-103(e) के रूप में समाहित होगा तथा उक्त हद तक पूर्व के संहिता/नियम/ परिपत्र द्वारा कृत सभी प्रावधान अवकाशित रगड़ी जायेंगे।

के कारण प्राथमिकता दी जायेगी सिवाय ऐसे मामलों में, जिसमें समान दर वाले सभी संवेदकों को उस वित्तीय वर्ष में एक-एक कार्य के लिए प्राथमिकता मिल चुकी हो।

(ii) निबंधन में संवेदकों के जो पता अंकित है, वे यदि उस जिला में पड़े जिसमें निविदा का कार्य होना है तभी उस संवेदक को स्थानीय माना जायेगा। यदि कार्य एक से अधिक जिला में है तब उनमें से किसी भी जिला में, निबंधन का पता पड़े तब उस संवेदक को स्थानीय माना जायेगा।

(iii) जिस श्रेणी में संवेदक निबंधित हो, उस श्रेणी में और उससे एक श्रेणी नीचे तक के कार्य में समान दर होने पर वे प्राथमिकता के लिये विचारणीय होंगे। परन्तु वरीयता का आधार जिस श्रेणी की निविदा विचाराधीन हो, उसी श्रेणी में निबंध की तिथि होगी। यदि कोई संवेदक अपने वर्तमान निबंधन की श्रेणी से एक श्रेणी नीचे की निविदा देते हैं और यदि वे इससे पूर्व वर्तमान श्रेणी से नीचे की श्रेणी में निबंधित थे, तब उनके वरीयता की गणना नीचे की श्रेणी में निबंधन की तिथि के आधार पर ही की जा सकती है।

(iv) जिस संगठन में अभी तक निबंधन की प्रणाली लागू नहीं हो सकी है, उसमें स्थानीयता का आधार जिला पदाधिकारी द्वारा निर्गत आवासीय प्रमाण-पत्र होगा।

(III) झारखण्ड पथ निर्माण संवेदक निबंधन / संशोधन नियमावली-2012 का नियम 4.5 - निविदा निर्णय के समय वरीयता का निर्धारण गत तीन वित्तीय वर्षों में संबंधित श्रेणी के सफलता पूर्वक किए गए कार्यों के आधार पर होगा अर्थात् ज्यादा संख्या में विहित श्रेणी के कार्य पूरा करने वाले संवेदक कम संख्या में कार्य पूरा करने वाले संवेदक से वरीय माने जाएंगे। दो अलग श्रेणी के संवेदकों की पारस्परिक वरीयता का आधार भी निबंधित श्रेणी में पूर्ण किए गए कार्यों की संख्या होगी। यदि पूर्ण किए गए कार्यों की संख्या समान हो वैसे स्थिति में उच्चतर श्रेणी के संवेदक को वरीय माना जाएगा।

2 (iii) Mobilization Advance के संबंध में :-

पथ निर्माण विभाग, झारखण्ड सरकार के संकल्प सं-3211(S) दि० 05.06.2018 द्वारा Standard Bidding Document की कंडिका-51.1 of Section-3 (Conditions of Contract) में निम्न संशोधन किया गया है:-

"The Employer shall make advance payment to the Contractor of the amounts stated in the Contract Data by the date stated in the Contract Data, against provision by the Contractor of an Unconditional Bank Guarantee in a form and by a bank acceptable to the employer in amounts and currencies equal to the advance payment. The guarantee shall remain effective until the advance payment has been repaid. But the amount of guarantee shall be progressively reduced by the amounts repaid by the Contractor. Interest will be charged @ 10% quarterly compounded.

The interest will be charged with the installment of recovery of mobilization advance."

Mobilization Advance के संबंध में पथ निर्माण विभाग द्वारा अपनायी गयी व्यवस्था (जिसमें Mobilization Advance पर interest देय है (पथ निर्माण विभाग का संकल्प-3211(S) दिनांक-05.06.2018, प्रति संलग्न) के अनुसार कार्रवाई अन्य कार्य विभागों के द्वारा भी की जायेगी।

(ख) mobilization advance दिए जाने की स्थिति में पथ निर्माण विभाग के उपरोक्त संशोधन को सभी विभागों के Contract Document में सम्मिलित किया जाय साथ ही Equipment advance हेतु भी यह व्यवस्था लागू होगी।

2. (iv) इस प्रकार प्रत्यायोजित शक्ति/संशोधित प्रावधान से यदि कोई पृथक व्यवस्था किसी कार्य विभाग में यदि लागू हो तब वह स्वतः संशोधित मानी जाएगी।

(3) प्रस्ताव पर मंत्रिपरिषद् का अनुमोदन प्राप्त है।

अनुलग्नक :- सद्योक्त

आदेश: आदेश दिया जाता है कि इस संकल्प को झारखण्ड राजपत्र के अगले असाधारण अंक में प्रकाशित किया जाय तथा इसकी प्रतियाँ प्रधान महालेखाकार (अंकेक्षण), झारखण्ड, राँची/सभी विभाग/विभागध्यक्ष को प्रेषित किया जाय।

झारखण्ड राज्यपाल के आदेशानुसार

सरकार के सचिव,
पथ निर्माण विभाग,
झारखण्ड, राँची।

ज्ञानांक- ००नि०वि०/विचि०-०६-३३/२००७(अंश-१) -2146(S) दिनांक : 09/09/2020
प्रतिलिपि - अधीक्षक, राजकीय मुद्रणालय, डोरण्डा, राँची को सूचनाार्थ एवं राजपत्र के आगामी अंक में प्रकाशनार्थ प्रेषित। अनुरोध है कि राजपत्र को 200 (दो सौ) प्रति पथ निर्माण विभाग, झारखण्ड, राँची को उपलब्ध करायी जाय।

सरकार के सचिव,
पथ निर्माण विभाग,
झारखण्ड, राँची।

ज्ञापक - प0नि0वि0/विविध-06-33/2007(अंश-1) -2146(S) दिनांक 09/09/2020
प्रतिलिपि:- मुख्य सचिव, झारखण्ड, राँची/विकास आयुक्त, झारखण्ड, राँची/मुख्यमंत्री के प्रधान सचिव, झारखण्ड, राँची/अपर मुख्य सचिव/प्रधान सचिव/सचिव/मंत्रिमंडल सचिवालय एवं निगरानी विभाग, झारखण्ड, राँची/योजना-सह-वित्त विभाग झारखण्ड, राँची/उर्जा विभाग, झारखण्ड, राँची/पेयजल एवं स्वच्छता विभाग, झारखण्ड, राँची/जल संसाधन विभाग, झारखण्ड, राँची/नगर विकास एवं आवास विभाग झारखण्ड, राँची/ग्रामीण कार्य विभाग झारखण्ड, राँची/ग्रामीण कार्य विभाग (ग्रामीण कार्य मामले) झारखण्ड, राँची/भवन निर्माण विभाग झारखण्ड, राँची/पथ निर्माण विभाग झारखण्ड, राँची/सभी प्रमंडलीय आयुक्त/सभी विभाग/ सभी विभागाध्यक्ष, झारखण्ड, राँची/सभी अभियन्ता प्रमुख, पथ निर्माण विभाग/भवन निर्माण विभाग/ग्रामीण कार्य विभाग/उर्जा विभाग/पेयजल एवं स्वच्छता विभाग/जल संसाधन विभाग/तकनीकी परीक्षक कोषांग, झारखण्ड, राँची/सभी मुख्य अभियन्ता, पथ निर्माण विभाग/भवन निर्माण विभाग/ग्रामीण कार्य विभाग/उर्जा विभाग/पेयजल एवं स्वच्छता विभाग/जल संसाधन विभाग, झारखण्ड, राँची/ मुख्यालय स्थित सभी राजपत्रित पदाधिकारी/सभी प्रशाखा पदाधिकारी को सूचनार्थ एवं आवरयक कार्रवाई हेतु प्रेषित।

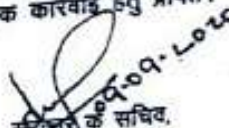
सचिव,
पथ निर्माण विभाग,
झारखण्ड, राँची।

ज्ञापक:- प0नि0वि0/विविध-06-33/2007(अंश-1) -2146(S) दिनांक 09/09/2020
प्रतिलिपि :- प्रधान महालेखाकार (अंकेक्षण), झारखण्ड, राँची को सूचनार्थ एवं आवरयक कार्रवाई हेतु प्रेषित।

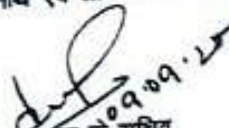
सचिव,
पथ निर्माण विभाग,
झारखण्ड, राँची।

ज्ञापक:- प0नि0वि0/विविध-06-33/2007(अंश-1) -2146(S) दिनांक : 09/09/2020
प्रतिलिपि :- प्रशाखा पदाधिकारी, प्रशाखा-8, पथ निर्माण विभाग, झारखण्ड, राँची को सभी सम्बन्धित को ई-मेल (E-mail) से भेजने एवं ई-प्रोक्चोरमेंट सेल, पथ निर्माण विभाग, झारखण्ड, राँची को वेबसाईट www.jharkhand.gov.in/troad पर upload करने हेतु प्रेषित।

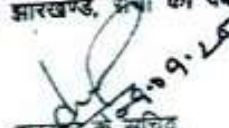
सचिव,
पथ निर्माण विभाग,
झारखण्ड, राँची।